

Hints of Exceptional Grand Unification at the LHC

Jürgen R. Reuter

DESY Hamburg

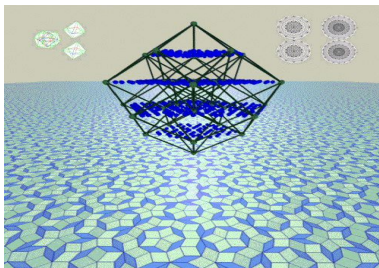

Seminar, SLAC, 4. May 2012

Supersymmetric Grand Unification



Prime Example: (SUSY) $SU(5)$

$$SU(5) \xrightarrow{M_X} SU(3)_c \times SU(2)_w \times U(1)_Y \xrightarrow{M_Z} SU(3)_c \times U(1)_{em}$$

$SU(5)$ has $5^2 - 1 = 24$ generators:

$$24 \rightarrow \underbrace{(8, 1)_0}_{G_\alpha^\beta} \oplus \underbrace{(1, 3)_0}_W \oplus \underbrace{(1, 1)_0}_B \oplus \underbrace{(3, 2)_{\frac{5}{3}}}_{X, Y} \oplus \underbrace{(\bar{3}, 2)_{-\frac{5}{3}}}_{\bar{X}, \bar{Y}}$$

Prime Example: (SUSY) $SU(5)$

$$SU(5) \xrightarrow{M_X} SU(3)_c \times SU(2)_w \times U(1)_Y \xrightarrow{M_Z} SU(3)_c \times U(1)_{em}$$

$SU(5)$ has $5^2 - 1 = 24$ generators:

$$24 \rightarrow \underbrace{(8, 1)_0}_{G_\alpha^\beta} \oplus \underbrace{(1, 3)_0}_W \oplus \underbrace{(1, 1)_0}_B \oplus \underbrace{(3, 2)_{\frac{5}{3}}}_{X, Y} \oplus \underbrace{(\bar{3}, 2)_{-\frac{5}{3}}}_{\bar{X}, \bar{Y}}$$

$$A = g \sum_{a=1}^{24} A^a \frac{\lambda^a}{2} = \frac{g}{\sqrt{2}} \left(\begin{array}{ccc|cc} \sqrt{2} G^a \frac{\lambda_{GM}^a}{2} & & & \bar{X} & \bar{Y} \\ & & & \bar{X} & \bar{Y} \\ & & & \bar{X} & \bar{Y} \\ \hline X & Y & X & & \\ Y & Y & Y & \sqrt{2} W^a \frac{\sigma}{2} & \end{array} \right)$$

$$- \frac{g}{2\sqrt{15}} B \left(\begin{array}{ccc|cc} -2 & & & & \\ & -2 & & & 0 \\ & & -2 & & \\ \hline & & & 0 & +3 \\ & & & & +3 \end{array} \right)$$

Fermions (Matter superfields)

Only possible way to combine matter:

$$\bar{\mathbf{5}} = \begin{array}{|c|} \hline \square \\ \hline \square \\ \hline \square \\ \hline \end{array} : \begin{pmatrix} d^c \\ d^c \\ d^c \\ l \\ -\nu_\ell \end{pmatrix} \quad \mathbf{10} = \begin{array}{|c|} \hline \square \\ \hline \square \\ \hline \end{array} : \frac{1}{\sqrt{2}} \left(\begin{array}{ccc|cc} 0 & u^c & -u^c & -u & -d \\ -u^c & 0 & u^c & -u & -d \\ u^c & -u^c & 0 & -u & -d \\ \hline u & u & u & 0 & -e^c \\ d & d & d & e^c & 0 \end{array} \right)$$

$$\bar{\mathbf{5}} = (\bar{\mathbf{3}}, \mathbf{1})_{\frac{2}{3}} \oplus (\mathbf{1}, \mathbf{2})_{-1} \quad \mathbf{10} = (\mathbf{3}, \mathbf{2})_{\frac{1}{3}} \oplus (\bar{\mathbf{3}}, \mathbf{1})_{-\frac{4}{3}} \oplus (\mathbf{1}, \mathbf{1})_2$$

Remarks

- ▶ $\mathbf{2} = \square = \bar{\mathbf{2}}$, $(\mathbf{5} \otimes \mathbf{5})_a = \mathbf{10}$, $(\mathbf{3} \otimes \mathbf{3})_a = \bar{\mathbf{3}}$, $(\square \otimes \square)_a = \begin{array}{|c|} \hline \square \\ \hline \square \\ \hline \end{array}$
- ▶ Quarks and leptons in the same multiplet
- ▶ Condition of tracelessness \Rightarrow (color!)
- ▶ $\bar{\mathbf{5}}$ and $\mathbf{10}$ have equal and opposite anomalies
- ▶ ν^c must be $SU(5)$ singlet

Interactions

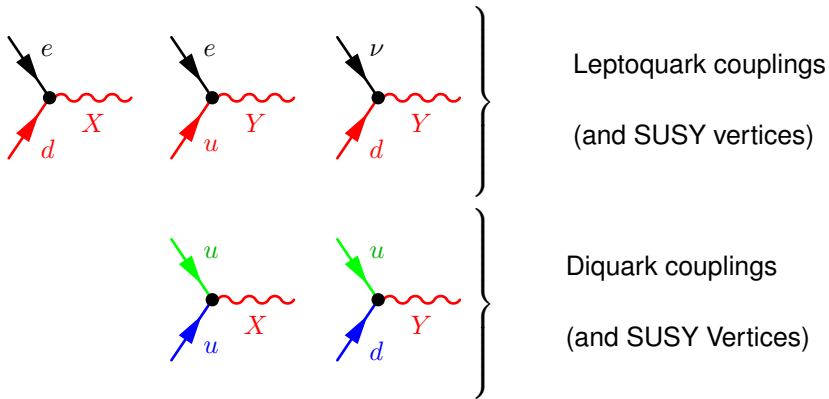

Vector bosons induce e.g.

decay $p \rightarrow e^+ \pi^0$

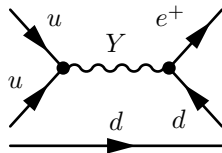

Interactions

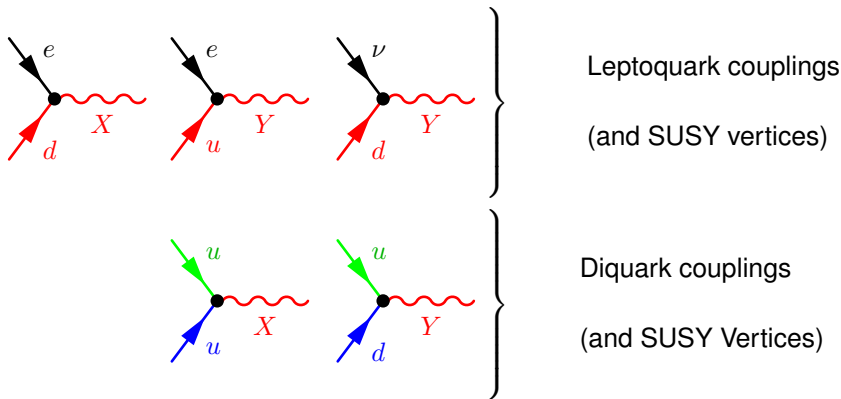

Proton Lifetime with $\alpha(M_{GUT}) \sim \frac{1}{24}$ and $M_{GUT} \sim 2 \times 10^{16}$ GeV:

$$\tau(p \rightarrow e^+ \pi^0) \sim \frac{M_{GUT}^4}{[\alpha(M_{GUT})]^2 m_p^5} \rightarrow 10^{31 \pm 1} \text{ years}$$

The Doublet-Triplet Splitting

$SU(5)$ breaking: Higgs Σ in adjoint **24** rep.

$$\langle \Sigma \rangle = w \times \text{diag}(1, 1, 1, -\frac{3}{2}, -\frac{3}{2}) \quad M_X = M_Y = \frac{5}{2\sqrt{2}} g w$$

other breaking mechanisms possible (e.g. orbifold)

The Doublet-Triplet Splitting

$SU(5)$ breaking: Higgs Σ in adjoint **24** rep.

$$\langle \Sigma \rangle = w \times \text{diag}(1, 1, 1, -\frac{3}{2}, -\frac{3}{2}) \quad M_X = M_Y = \frac{5}{2\sqrt{2}} g w$$

other breaking mechanisms possible (e.g. orbifold)

(MS)SM Higgs(es) in $\mathbf{5} \oplus \bar{\mathbf{5}}$

$$\mathbf{5} = \square : \begin{pmatrix} D \\ D \\ D \\ h^+ \\ h^0 \end{pmatrix} \quad \bar{\mathbf{5}} = \begin{matrix} \square \\ \square \\ \square \\ \square \end{matrix} : \begin{pmatrix} D^c \\ D^c \\ D^c \\ h^- \\ -h^0 \end{pmatrix}$$

$$\mathbf{5} = (\mathbf{3}, \mathbf{1})_{-\frac{2}{3}} \oplus (\mathbf{1}, \mathbf{2})_1 \quad \bar{\mathbf{5}} = (\bar{\mathbf{3}}, \mathbf{1})_{\frac{2}{3}} \oplus (\mathbf{1}, \mathbf{2})_{-1}$$

- ▶ D, D^c coloured triplets with charges $\pm \frac{1}{3}$
- ▶ induce proton decay, too $m_H \sim 100 \text{ GeV}, m_D \sim 10^{16} \text{ GeV}$
- ▶ **Doublet-Triplet Splitting Problem**

Proton Decay experimentum crucis for GUTs

- ▶ Tracking calorimeter (SOUDAN) or RICH Cerenkov counter
- ▶ Super-Kamiokande: 50 kt water RICH
- ▶ For reconstruction: measure time and location

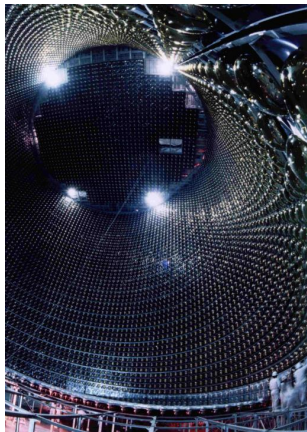
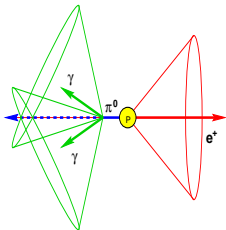

Proton Decay experimentum crucis for GUTs

- ▶ Tracking calorimeter (SOUDAN) or RICH Cerenkov counter
- ▶ Super-Kamiokande: 50 kt water RICH
- ▶ For reconstruction: measure time and location

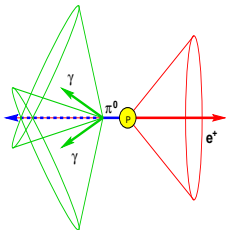

Kanal	$\tau_p (10^{30} \text{ years})$
$p \rightarrow \text{invisible}$	0.21
$p \rightarrow e^+ \pi^0$	1600
$p \rightarrow \mu^+ \pi^0$	473
$p \rightarrow \nu \pi^+$	25
$p \rightarrow \nu K^+$	670
$p \rightarrow e^+ \eta^0$	312
$p \rightarrow \mu^+ \eta^0$	126
$p \rightarrow e^+ \rho^0$	75
$p \rightarrow \mu^+ \rho^0$	110
$p \rightarrow \nu \rho^+$	162
$p \rightarrow e^+ \omega^0$	1000
$p \rightarrow \mu^+ \omega^0$	117
$p \rightarrow e^+ K^0$	150
$p \rightarrow \mu^+ K^0$	1300
$p \rightarrow \nu K^+$	2300
$p \rightarrow e^+ \gamma$	670
$p \rightarrow \mu^+ \gamma$	478

New experiments:

HyperK (1 Mt), UNO (650 kt), European project Fréjus (1 Mt)

Precision: 10 years running $\implies 10^{34} - 10^{35}$ years

Why chiral exotics?

JRR/Kilian, PLB 642 (2006), 81, JRR 0709.4202

Proof of Unification only with megatons? What about colliders?

- SPA: Super precision accurately
- Alternative: Search for chiral exotics
- Physics beyond the MSSM as lever-arm to GUT scale

μ problem

- NMSSM trick
- Singlett Superfield with TeV-scale vacuum expectation value

Doublet-Triplet Splitting Problem; Longevity of the Proton

- Keep D, D^c superfields at the TeV scale
- New mechanism against proton decay
- Different unification scenario

Proton Decay

- ▶ Flavour symmetry can save the proton
- ▶ Discrete parity eliminates either LQ/DQ couplings

Exceptional Lie Algebras

Lie, 1881; Dynkin, 1957

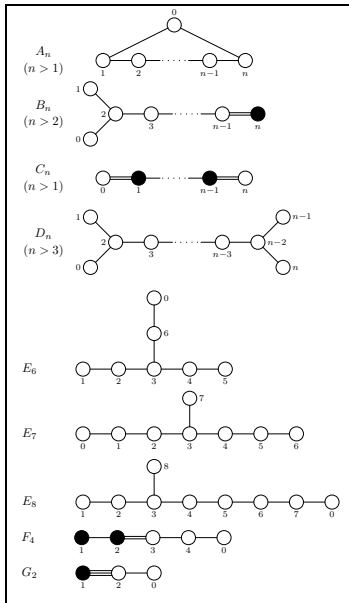

E_6 SUSY Grand Unification

Supersymmetry: allows consistent extrapolation to (very) high scales

- ⇒ Two Higgs doublets H^u, H^d
- ⇒ SM superpartners at the TeV scale

Bottom-Up approach: only MSSM

- ▶ Matter-Higgs unification
- ▶ **Ansatz**: all new particles at the TeV scale

$$Q_L = (\mathbf{3}, \mathbf{2})_{\frac{1}{6}}, Q'_Q$$

$$u^c = (\bar{\mathbf{3}}, \mathbf{1})_{-\frac{2}{3}}, Q'_u$$

$$d^c = (\bar{\mathbf{3}}, \mathbf{1})_{\frac{1}{3}}, Q'_d$$

$$H^u = (\mathbf{1}, \mathbf{2})_{\frac{1}{2}}, Q'_{H^u}$$

$$H^d = (\mathbf{1}, \mathbf{2})_{-\frac{1}{2}}, Q'_{H^d}$$

$$S = (\mathbf{1}, \mathbf{1})_{0}, Q'_S \neq 0$$

$$L_L = (\mathbf{1}, \mathbf{2})_{-\frac{1}{2}}, Q'_L$$

$$\nu^c = (\mathbf{1}, \mathbf{1})_{0}, Q'_\nu = 0$$

$$e^c = (\mathbf{1}, \mathbf{1})_{1}, Q'_e$$

$$D = (\mathbf{3}, \mathbf{1})_{-\frac{1}{3}}, Q'_D$$

$$D^c = (\bar{\mathbf{3}}, \mathbf{1})_{\frac{1}{3}}, -Q'_D$$

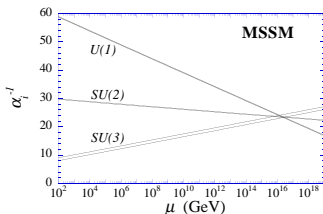

Running With Triplets

Kilian/JR, 2006

Bottom-up approach: MSSM with one generation of triplets

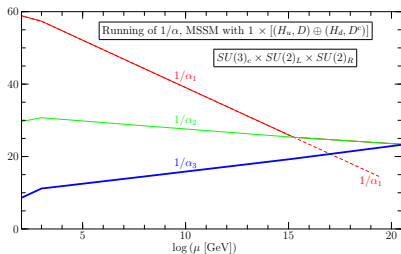

10^{15} GeV: crossing of $SU(2)_L$ and $U(1)_Y$

\Rightarrow unification to LR symmetry $SU(2)_L \times SU(2)_R$, requires ν_R^c

$SU(3)_c$ crosses at 10^{21} GeV: too high

Running With Triplets

Kilian/JR, 2006

Bottom-up approach: MSSM with one generation of triplets

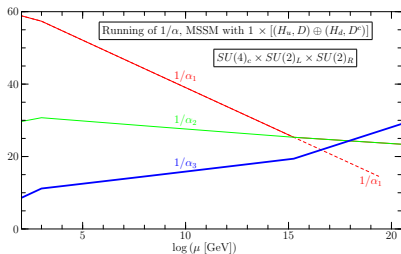

10^{15} GeV: crossing of $SU(2)_L$ and $U(1)_Y$

\Rightarrow unification to LR symmetry $SU(2)_L \times SU(2)_R$, requires ν_R^c

$SU(3)_c$ crosses at 10^{21} GeV: too high

\Rightarrow extend to $SU(4)_C$: unification possible at 10^{18} GeV

Running With Triplets

Kilian/JR, 2006

Complete Model:

- ▶ Full SUSY E_6/G_{Tri} matter spectrum above 10^3 GeV, except ν^c

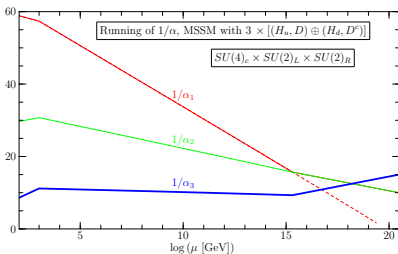

- ▶ PS symmetry with ν_R above 10^{15} GeV

$$\mathbf{Q}_L = (Q, L) = (\mathbf{4}, \mathbf{2}, \mathbf{1}) \quad \mathbf{D} = (D, D^c) = (\mathbf{6}, \mathbf{1}, \mathbf{1})$$

$$\mathbf{Q}_R = ((u^c, d^c), (\nu^c, \ell^c)) = (\bar{\mathbf{4}}, \mathbf{1}, \mathbf{2}) \quad \mathbf{S} = (\mathbf{1}, \mathbf{1}, \mathbf{1})$$

$$\mathbf{H} = (H_u, H_d) = (\mathbf{1}, \mathbf{2}, \mathbf{2})$$

- ▶ E_6 symmetry (and possibly extra fields) at 10^{18} GeV

Intermediate Pati-Salam symmetry

JRR et al. 2006-9, King et al. 2008

- ▶ Additional particles destroy MSSM unification
- ▶ Unification below Λ_{Planck} with intermediate

$SU(4) \times SU(2)_L \times SU(2)_R [\times U(1)_X]$ Pati-Salam symmetry at $\sim 10^{15-16}$ GeV

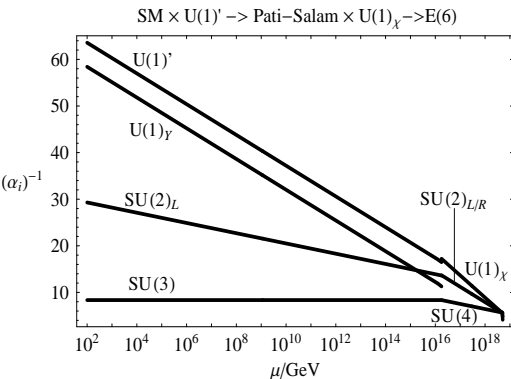

- ▶ $SU(2)_R$ and $SU(2)_L$: identical content/running
- ▶ Crossing of $SU(4)$ with $SU(2)_{L/R}$ couplings determines E_6 scale
- ▶ Lepton number: 4. colour
- ▶ $T_{SU(4)}^{15} \propto \frac{B-L}{2}$
- ▶ $Y = \frac{B-L}{2} + T_R^3$
- ▶ $U(1)$ Matching condition

$$\frac{1}{g_Y^2} = \frac{2}{5} \frac{1}{g_{B-L}^2} + \frac{3}{5} \frac{1}{g_R^2}$$
- ▶ Integrating out ν^c : (see-saw)

\Rightarrow correct breaking

$U(1)$ Mixing

Braam/Knochel/JRR, JHEP 1006:013; King et al., 2009, Braam/JRR, EPJC 72 (2012) 1885

- Two $U(1)$ factors below the intermediate scale
- Kinetic mixing: non-rational coefficients (gauge couplings)

$$\mathcal{L} = i g_i Q_i^a A_i^\mu \bar{\psi}^a \gamma_\mu \psi^a - \frac{1}{4} F_i^{\mu\nu} \delta_{ij} F_{\mu\nu,j} - \frac{1}{4} F_i^{\mu\nu} \Delta Z_{ij} F_{\mu\nu,j}.$$

- Effects for the running:

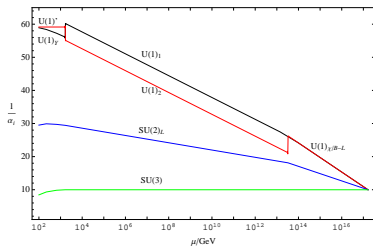
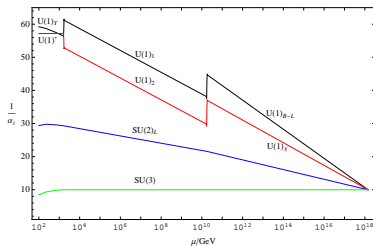

$U(1)$ Mixing

Braam/Knochel/JRR, JHEP 1006:013; King et al., 2009, Braam/JRR, EPJC 72 (2012) 1885

- Two $U(1)$ factors below the intermediate scale
- Kinetic mixing: non-rational coefficients (gauge couplings)

$$\mathcal{L} = i g_i Q_i^a A_i^\mu \bar{\psi}^a \gamma_\mu \psi^a - \frac{1}{4} F_i^{\mu\nu} \delta_{ij} F_{\mu\nu,j} - \frac{1}{4} F_i^{\mu\nu} \Delta Z_{ij} F_{\mu\nu,j}.$$

- Effects for the running:

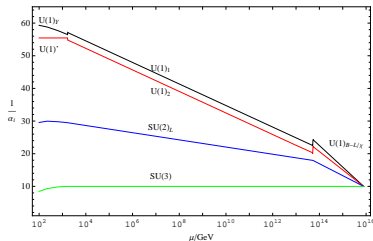
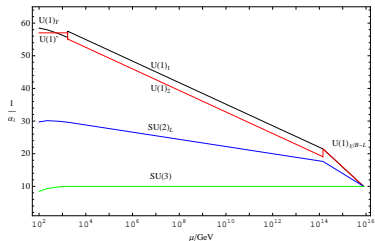

$U(1)$ Mixing

Braam/Knochel/JRR, JHEP 1006:013; King et al., 2009, Braam/JRR, EPJC 72 (2012) 1885

- Two $U(1)$ factors below the intermediate scale
- Kinetic mixing: non-rational coefficients (gauge couplings)

$$\mathcal{L} = i g_i Q_i^a A_i^\mu \bar{\psi}^a \gamma_\mu \psi^a - \frac{1}{4} F_i^{\mu\nu} \delta_{ij} F_{\mu\nu,j} - \frac{1}{4} F_i^{\mu\nu} \Delta Z_{ij} F_{\mu\nu,j}.$$

- Effects for the running:

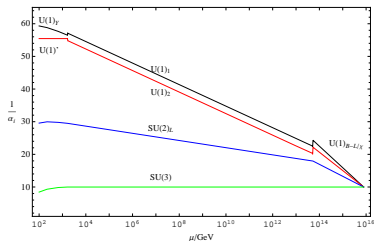
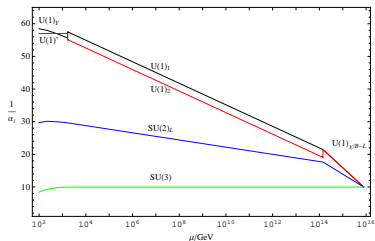

- Same effect for soft-breaking terms: **interesting singlino mixing**

The Superpotential / Sketch of a Model

Kilian/JR, 2006

Superpotential:

$$\mathcal{W} = \mathcal{W}_{\text{MSSM}} + \mathcal{W}_D + \mathcal{W}_N$$

$$\mathcal{W}_{\text{MSSM}} = Y^u u^c Q H_u + Y^d d^c Q H_d + Y^e e^c L H_d$$

$$\mathcal{W}_D = Y^D D u^c e^c + Y^{D^c} D^c Q L$$

$$\mathcal{W}_S = Y^{S_H} S H_u H_d + Y^{S_D} S D D^c$$

- Corresponding soft-breaking terms
- t/\tilde{t} drive $m_{H_u}^2$ negative
- D/\tilde{D} drive m_S^2 negative
- $U(1)'$ D -terms provide large enough S quartics (and H quartics)
- Configuration drives system to large $\langle S \rangle \sim 1 - 2 \text{ TeV}$
- R parity is not sufficient to protect proton: discrete parity to **distinguish LQ/DQ couplings** (or flavor symmetry)
- Flavored Higgs sector: additional parity to beware of FCNCs \Rightarrow **H parity**

Griest/Sher, 1989

Problems and E_6 /Pati-Salam breaking

JRR et al., 2012

- E_6 superpotential vanishes $\Rightarrow E_6$ operators generate PS superpotential Power suppression: top Yukawa?
- discrete symmetry to discriminate lepto-/diquark couplings/ H -Parity violate GUT multiplet structure
- strong constraints from perturbativity above Λ_{PS}
- Difficulties to find representations for PS breaking
 - ▶ **27**, **351**, and **351'** break E_6 to rank 5
 $U(1)_X$ broken, no quartic singlet potential
 - ▶ No rank reduction: **adjoint breaking**
 - ▶ Breaking through $\langle (27)(\overline{27}) \rangle$ or $\langle 27 \rangle \langle \overline{27} \rangle$ $27 \times \overline{27} = 1 + 78 + 650$
 - ▶ **650** smallest rep for $E_6 \rightarrow G_{PS} \times U(1)$
 - ▶ Possible to construct superpotential which does the breaking and allows leptoquark couplings

Problems and E_6 /Pati-Salam breaking

JRR et al., 2012

- E_6 superpotential vanishes $\Rightarrow E_6$ operators generate PS superpotential Power suppression: top Yukawa?
- discrete symmetry to discriminate lepto-/diquark couplings/ H -Parity violate GUT multiplet structure
- strong constraints from perturbativity above Λ_{PS}
- Difficulties to find representations for PS breaking
 - ▶ **27, 351, and 351'** break E_6 to rank 5
 $U(1)_X$ broken, no quartic singlet potential
 - ▶ No rank reduction: **adjoint breaking**
 - ▶ Breaking through $\langle (27)(\overline{27}) \rangle$ or $\langle 27 \rangle \langle \overline{27} \rangle$ $27 \times \overline{27} = 1 + 78 + 650$
 - ▶ **650** smallest rep for $E_6 \rightarrow G_{PS} \times U(1)$
 - ▶ **Possible to construct superpotential which does the breaking and allows leptoquark couplings**

Automatic Irrep Decomposition

Mallot/JRR; Horst/JRR: CleGo, CPC (2011)

27

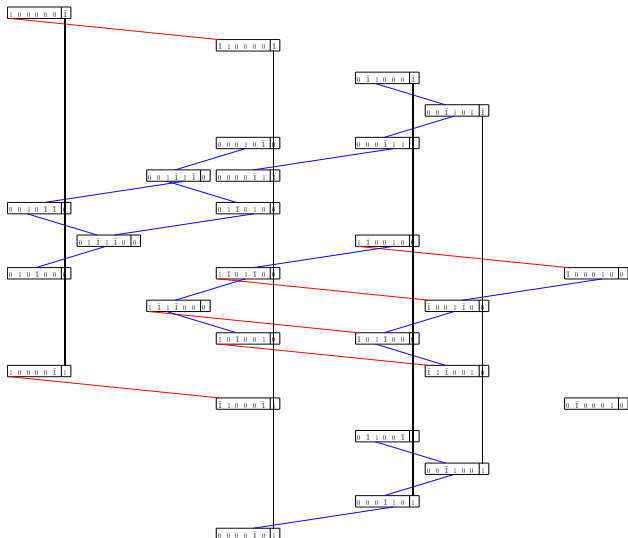

Automatic Irrep Decomposition

Mallot/JRR; Horst/JRR; CleGo, CPC (2011)

78

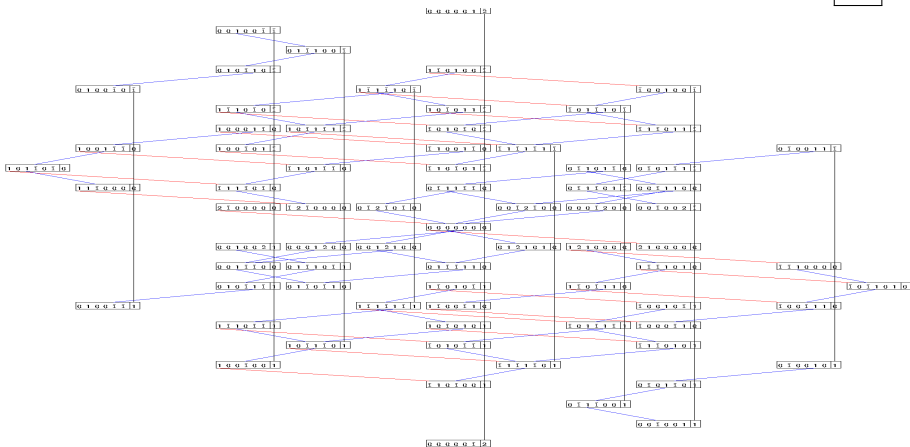

Automatic Irrep Decomposition

Mallot/JRR; Horst/JRR; CleGo, CPC (2011)

351'

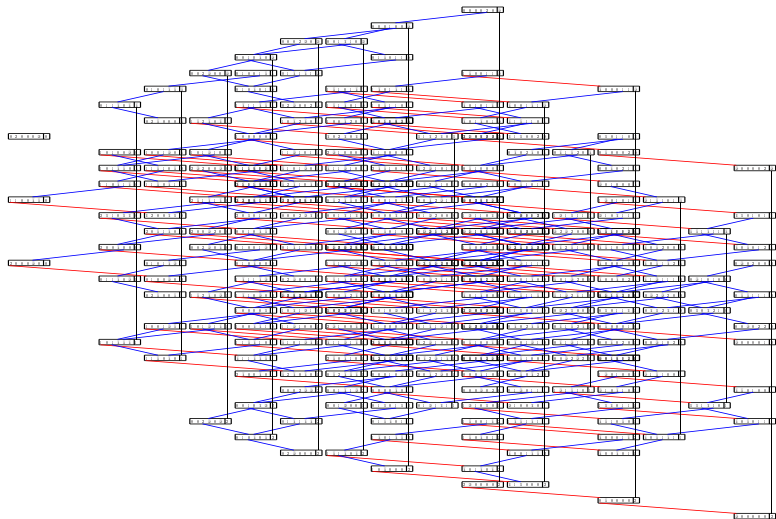

Automatic Irrep Decomposition

Mallot/JRR; Horst/JRR; CleGo, CPC (2011)

2925

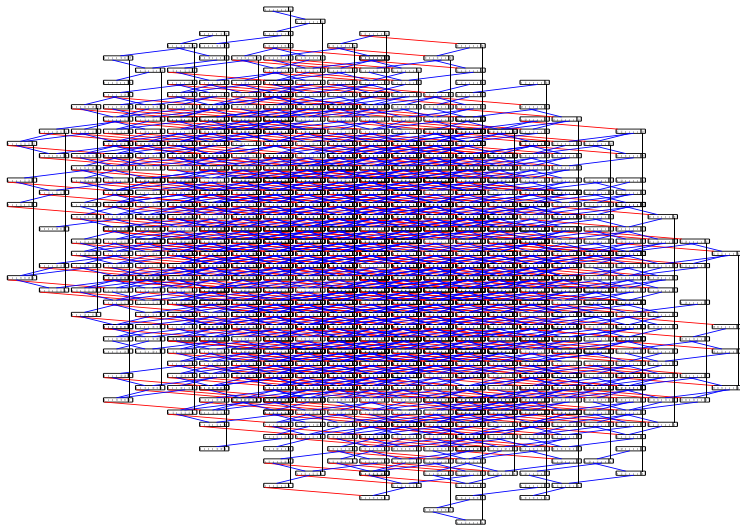

Alternative: Orbifold Breaking in Extra Dimensions

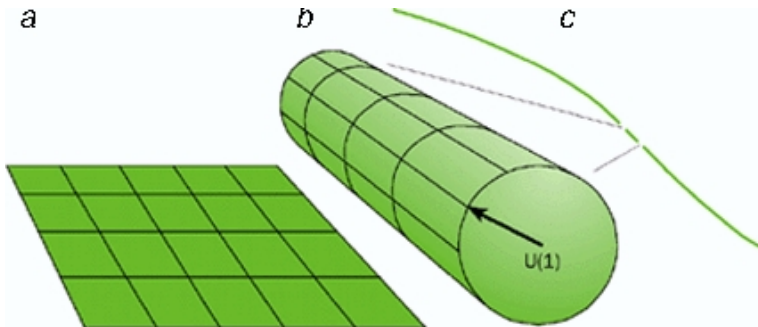

Asaki/Buchmüller/Covi, 01-02; Hebecker/Ratz, 03; Kobayashi/Raby/Zhang, 04; Förste/Nilles/Wingerter, 05;

Buchmüller/Hamaguchi/Lebedev/Ratz, 07; Lebedev/Nilles/Raby/Ramos-Sanchez/Ratz/Vaudrevange, 07-08; Groot

Nibbelink/Held/Ruehle/Trapletti/Vaudrevange, 09

Alternative: Orbifold Breaking in Extra Dimensions

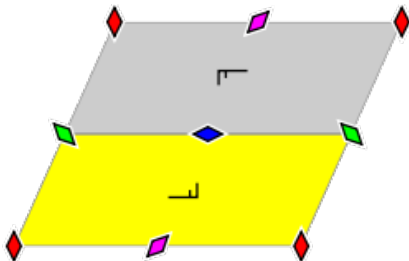
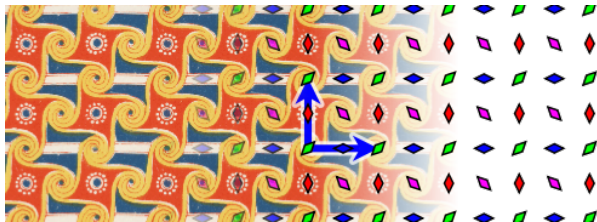

Alternative: Orbifold Breaking in Extra Dimensions

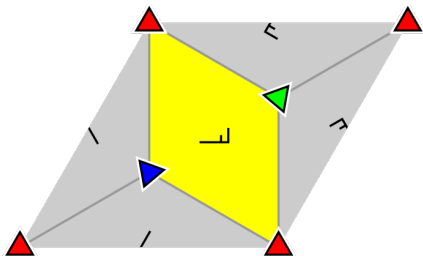
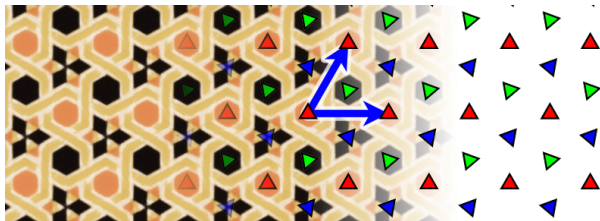

Alternative: Orbifold Breaking in Extra Dimensions

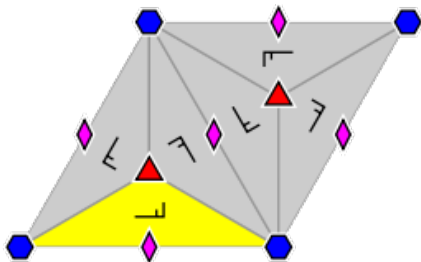
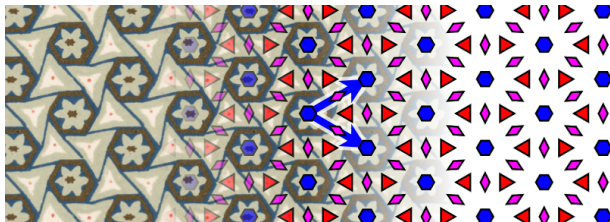

PS models from 5D orbifolds

Braam/Knoche/JRR, JHEP 1006:013

$E_6 \rightarrow PS \times U(1)$ breaking on
 $S^1/(\mathbb{Z}_2 \times \mathbb{Z}'_2)$



$SU(6) \times SU(2)_L$	$SO(10)_{\sqrt{6}Q_X}$	$16_{\frac{1}{2}}$	10_{-1}	1_2
$(\overline{15}, 1)$		$(\overline{4}, 1, 2)_{1/2}$	$(6, 1, 1)_{-1}$	$(1, 1, 1)_2$
$(6, 2)$		$(4, 2, 1)_{1/2}$	$(1, 2, 2)_{-1}$	\times

- ▶ LQ/DQ couplings from: $10 \ 16 \ 16, 6 \ 6 \ \overline{15}, \overline{15} \ \overline{15} \ \overline{15} \Rightarrow$ no way to forbid either of them
- ▶ Anomalies: $SU(6) \times SU(2)$ fixed point only vector-like matter
- ▶ Gauge shifts: $\overline{V} = (\frac{1}{2}, \frac{1}{2}, 0, \frac{1}{2}, \frac{1}{2}, 0), \quad \overline{V}' = (\frac{1}{2}, \frac{1}{2}, \frac{1}{2}, \frac{1}{2}, \frac{1}{2}, 0)$
- ▶ 5D E_6 **78** vector multiplet $\rightarrow 16_{-3/2} + \overline{16}_{3/2}, (20, 2)$
- ▶ 4 bulk 5D E_6 **27** hypermultiplet with $\mathbb{Z}_2 \times \mathbb{Z}'_2$ parities $(++), (--), (-+), (+-) \rightarrow (6, 1, 1)_{-1} + (1, 1, 1)_2, (4, 2, 1)_{\frac{1}{2}}, (\overline{4}, 1, 2)_{\frac{1}{2}}, (1, 2, 2)_{-1}$
- ▶ 3rd gen. from 2 bulk hypermultiplets + a brane-localized $16'_{\frac{1}{2}} + 16^3_{\frac{1}{2}}$
- ▶ **LQ-/DQ couplings** generated (only simultaneously), but **must be rendered small by hand**

LR Models from 6D Orbifolds

Braam/Knoche/JRR, JHEP 1006:013

- Consider: $\mathbb{R}^4 \times (\mathbb{R}^2/\Gamma)$, Γ one of the 17 crystallographic groups
- Use shifts of the bulk E_6 root lattice + discrete Wilson lines on the tori
- $E_6 \supset SU(3) \times SU(2)^2 \times U(1)^2$ breakings through $\mathbb{Z}_2, \mathbb{Z}_3, \mathbb{Z}_4, \mathbb{Z}_6$:

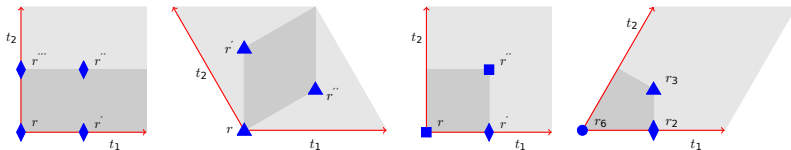

- H Parity: at least one fixed point to **distinguish Higgs/Matter**
- at least one fixed point to **discriminate LQ/DQ couplings**
- \mathbb{Z}_n Orbifold compactification breaks SUSY $(\xi_1, \bar{\xi}_2) \xrightarrow{\theta} (e^{-i\pi/n}\xi_1, e^{i\pi/n}\bar{\xi}_2)$
- 4D $\mathcal{N} = 1$ SUSY conserved by either:
 - ▶ Using 10D Lorentz phases:

$$\theta = \exp \left[\frac{A}{4} [\Gamma^5, \Gamma^6] + \frac{B}{4} [\Gamma^7, \Gamma^8] + \frac{C}{4} [\Gamma^9, \Gamma^{10}] \right]$$

- ▶ Non-trivial embedding of $SU(2)$ R symmetry

$$\theta = \exp \left[\frac{2\pi}{n} \frac{1}{4} ([\Gamma^5, \Gamma^6] + c_R i I^{3R}) \right]$$

Classification of Models

- $E_6 \supset H \supset SU(3) \times SU(2)^2 \times U(1)^2$ Breaking through $\mathbb{Z}_2, \mathbb{Z}_3, \mathbb{Z}_4$.

\mathbb{Z}_2	Subgroup H	Shift $2\bar{V}$
	$SO(10) \times U(1)_X$	$(1, 1, 0, 1, 1, 0)$
	$SU(6) \times SU(2)_R$	$(0, 0, 1, 0, 0, 0)$
	$SU(6) \times SU(2)_L$	$(1, 1, 1, 1, 1, 0)$
\mathbb{Z}_3	Subgroup H	Shift $3\bar{V}$
	$SU(3)_C \times SU(3)_L \times SU(3)_R$	$(0, 0, 1, -1, 0, 0)$
\mathbb{Z}_4	Subgroup H	Shift $4\bar{V}$
	$SU(3)_C \times SU(3)_L \times SU(2)_R \times U(1)$	$(0, 0, 1, 2, 0, 0)$
	$SU(3)_C \times SU(3)_R \times SU(2)_L \times U(1)$	$(-1, 1, 1, 1, 1, 0)$

- non-trivial ($H_i \not\subseteq H_j$) common invariant subgroups $H_i \cap H_j$ under two combined shifts

$\mathbb{Z}_2 \times \mathbb{Z}_2$	$SU(4)_C \times SU(2)_L \times SU(2)_R \times U(1)_X$
$\mathbb{Z}_2 \times \mathbb{Z}_3$	$SU(3)_C \times SU(2)_L \times SU(2)_R \times U(1)_{B-L} \times U(1)_X$
	$SU(3)_C \times SU(3)_L \times SU(2)_R \times U(1)$
	$SU(3)_C \times SU(3)_R \times SU(2)_L \times U(1)$
$\mathbb{Z}_2 \times \mathbb{Z}_4$	$SU(4)_C \times SU(2)_L \times SU(2)_R \times U(1)_X$
	$SU(3)_C \times SU(2)_L \times SU(2)_R \times U(1)_{B-L} \times U(1)_X$
$\mathbb{Z}_3 \times \mathbb{Z}_4$	$SU(3)_C \times SU(3)_L \times SU(2)_R \times U(1)$
	$SU(3)_C \times SU(3)_R \times SU(2)_L \times U(1)$
$\mathbb{Z}_4 \times \mathbb{Z}_4$	$SU(3)_C \times SU(2)_L \times SU(2)_R \times U(1)_{B-L} \times U(1)_X$

A specific Model

Braam/Knoche/JRR, JHEP 1006:013

- Use T^2/\mathbb{Z}_6 (a.k.a. $\mathbb{R}^2/632$ or p6)
- Shift vector $\vec{V}(r_6) = (\frac{1}{6}, -\frac{1}{6}, -\frac{1}{3}, -\frac{1}{2}, -\frac{1}{6}, 0)$ (in \overline{Q}_{B-L} direction)
- No discrete Wilson lines allowed

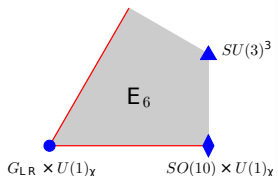

- ▶ Anomalies from bulk **78** chiral modes after projection
 $(\mathbf{16}_{-3/2} + \overline{\mathbf{16}}_{3/2}, (\overline{\mathbf{3}}, \mathbf{2}, \mathbf{1}) + (\overline{\mathbf{3}}, \mathbf{1}, \mathbf{2}), (\mathbf{3}, \mathbf{3}, \overline{\mathbf{3}}))$ cancel against **78** bulk hypermultiplet
- ▶ 3 gen. of **27** as brane-localized matter

$SU(3)^3 \setminus SO(10)_{Q_X}$	$\mathbf{16}_{\frac{1}{2}}$	$\mathbf{10}_{-1}$	$\mathbf{1}_2$
A = $(\overline{\mathbf{3}}, \mathbf{1}, \mathbf{3})$	$(\overline{\mathbf{3}}, \mathbf{1}, \mathbf{2})_{(-\frac{1}{3}, \frac{1}{2})}$	$(\overline{\mathbf{3}}, \mathbf{1}, \mathbf{1})_{(\frac{2}{3}, -1)}$	×
B = $(\mathbf{3}, \mathbf{3}, \mathbf{1})$	$(\mathbf{3}, \mathbf{2}, \mathbf{1})_{(\frac{1}{3}, \frac{1}{2})}$	$(\mathbf{3}, \mathbf{1}, \mathbf{1})_{(-\frac{2}{3}, -1)}$	×
C = $(\mathbf{1}, \overline{\mathbf{3}}, \overline{\mathbf{3}})$	$(\mathbf{1}, \mathbf{2}, \mathbf{1})_{(-1, \frac{1}{2})}$ $(\mathbf{1}, \mathbf{1}, \mathbf{2})_{(1, \frac{1}{2})}$	$(\mathbf{1}, \mathbf{2}, \mathbf{2})_{(0, -1)}$	$(\mathbf{1}, \mathbf{1}, \mathbf{1})_{(0, 2)}$

- ▶ Trinification FP $SU(3)^3$ (H -even!) to discriminate LQ/DQ couplings (3rd gen.):
 $\mathbf{27}^3 \rightarrow (\overline{\mathbf{3}}, \mathbf{1}, \mathbf{3})^3 + (\mathbf{3}, \mathbf{3}, \mathbf{1})^3 + (\mathbf{1}, \overline{\mathbf{3}}, \overline{\mathbf{3}})^3 + (\overline{\mathbf{3}}, \mathbf{1}, \mathbf{3})(\mathbf{3}, \mathbf{3}, \mathbf{1})(\mathbf{1}, \overline{\mathbf{3}}, \overline{\mathbf{3}})$
- ▶ 1.+2. gen. on $SO(10)$ FP. (allows for LQ couplings)
- ▶ LR symmetry breaking by brane-localized matter:

$$i) \quad L, l^c, \langle \nu^c \rangle + c.c. \sim (\mathbf{1}, \overline{\mathbf{3}}, \overline{\mathbf{3}}) \cap \mathbf{16} + c.c.$$

$$ii) \quad L, l^c, \langle \nu^c \rangle, H_u, H_d, S + c.c. \sim (\mathbf{1}, \overline{\mathbf{3}}, \overline{\mathbf{3}}) + c.c.$$

Model Building \Rightarrow Phenomenology



Scan of Parameter Space

Braam/JRR/Wiesler, 0909.3081; JRR et al., 2012

- ▶ # free parameters $\sim \mathcal{O}(100)$, additional assumptions:
 - Unified Soft-Breaking terms
 - Flavour structure
 ⇒ Restriction to 14 parameters
- ▶ Constraints:
 - (1) Experimental search limits for new particles
 - (2) Running couplings perturbative up to Λ_{E_6}
 - (3) Scalar (non-Higgs) mass terms positive
(\Leftrightarrow No false vacua)

- ▶ 14-dim. parameter space
 - ⇒ Grid Scan: $\rightarrow 10^{28}$ points
 - ▶ Investigation per point (RGE, Higgs potential minimisation, Calculation of masses) $\sim 10 - 100$ ms
- Lsg.: Monte-Carlo Markov chain through parameter space
- ⇒ Effective search for relevant parameter tuples

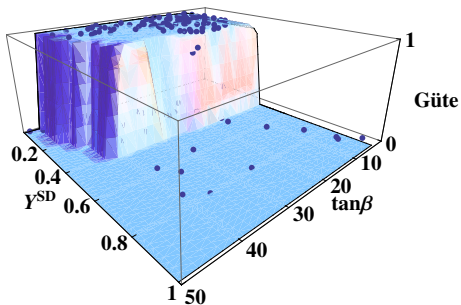

Generic Properties of Spectra

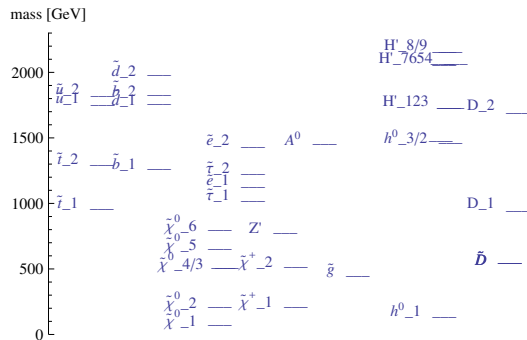

- Vanishing 1-loop QCD β function \Rightarrow **Light Gluino**
- Higgs- and neutralino sector different because of singlet superfield admixture
- light Z' (**peculiar asymmetries**)
- Flavoured Higgs sector: Unhiggses, Unhiggsinos
- Leptoquarks/Leptoquarkinos

Sample Spectra

$H_{\text{int}}, \bar{H}_{\text{int}}$	$i)$	$ii)$	$3ii)$	$i) + 2ii)$
$\Lambda_{\text{int}}/\text{GeV}$	1.6×10^{10}	3.0×10^{13}	1.3×10^{14}	4.9×10^{13}
$\Lambda_{\text{GUT}}/\text{GeV}$	1.3×10^{18}	1.5×10^{17}	7.2×10^{15}	7.2×10^{15}
$g' M_{Z'}$	0.471	0.467	0.476	0.482
Q'_X				
Q	0.224	0.231	0.234	0.232
u^c	0.283	0.261	0.250	0.257
d^c	0.055	0.067	0.073	0.069
D	-0.449	-0.462	-0.468	-0.464
D^c	-0.339	-0.328	-0.322	-0.326
L	0.114	0.097	0.089	0.094
e^c	0.165	0.201	0.218	0.208
H^u	-0.508	-0.492	-0.484	-0.489
H^d	-0.279	-0.298	-0.307	-0.301
S	0.787	0.790	0.790	0.790

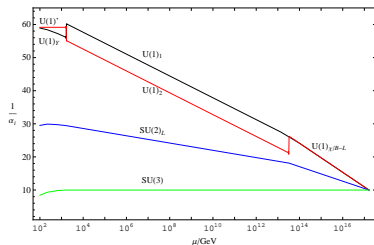
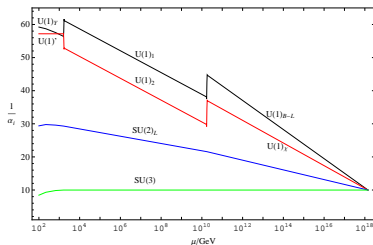

Sample Spectra

$H_{\text{int}}, \bar{H}_{\text{int}}$	$i)$	$ii)$	$3ii)$	$i) + 2ii)$
$\Lambda_{\text{int}}/\text{GeV}$	1.6×10^{10}	3.0×10^{13}	1.3×10^{14}	4.9×10^{13}
$\Lambda_{\text{GUT}}/\text{GeV}$	1.3×10^{18}	1.5×10^{17}	7.2×10^{15}	7.2×10^{15}
$g^i M, Z^i$	0.471	0.467	0.476	0.482
Q^i / X^i				
Q	0.224	0.231	0.234	0.232
u^c	0.283	0.261	0.250	0.257
d^c	0.055	0.067	0.073	0.069
D	-0.449	-0.462	-0.468	-0.464
D^c	-0.339	-0.328	-0.322	-0.326
L	0.114	0.097	0.089	0.094
e^c	0.165	0.201	0.218	0.208
H^u	-0.508	-0.492	-0.484	-0.489
H^d	-0.279	-0.298	-0.307	-0.301
S	0.787	0.790	0.790	0.790

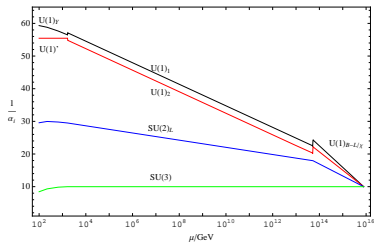
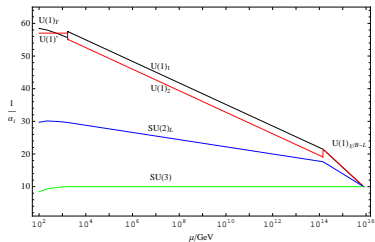

Sample Spectra

	Scenario A	Scenario B	Scenario C
y _{lq}	0.106	0.145	0.210
y _{lqc}	0.082	0.075	0.230
y _{sd}	0.397	0.856	0.655
y _{sh}	0.214	0.321	0.052
y _{nmssm}	0.173	0.145	0.150
M _g	1105	-1452	-1359
M _{gluino}	-820	-875	-841

h _{sm}	-764	-1261	-749
h _{lq}	372	-446	-376
h _{lqc}	-224	-0.9	-897
h _{sd}	-264	500	307
h _{sh}	351	-767	19
h _{nmssm}	22.5	-185	73
m _{sfer}	1689	814	1690
m _{dh}	1234	1154	1936
m _H	1959	1921	1465
m _D	816	805	826
m _S	1201	1921	1357
m _{int}	-1459	-1050	-845

- ▶ **Higgs boson:** A,C $m_h \approx 110$ GeV B $m_h \approx 107$ GeV
- ▶ **Z':** A, B $m_{Z'} \approx 2480$ GeV C $m_{Z'} \approx 2090$ GeV (*R-odd and H-odd*)
- ▶ **Dark Matter:** lightest dark Higgsino, $m_{\chi^\pm} \sim \mathcal{O}(1 - 1\text{GeV})$

Sample Spectra

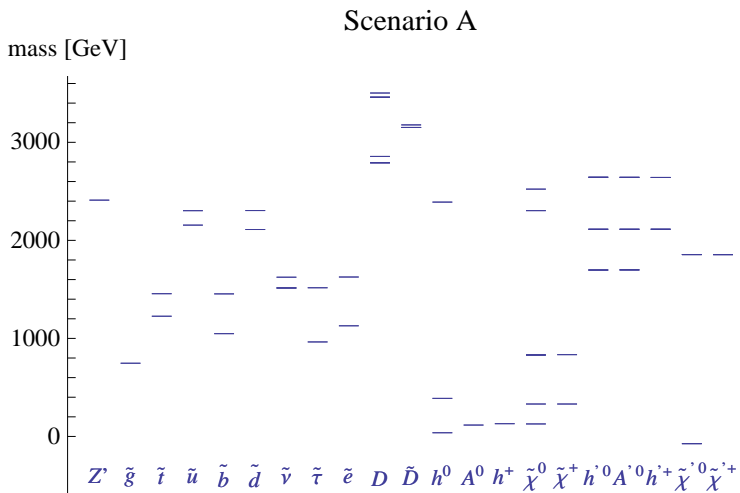

Sample Spectra

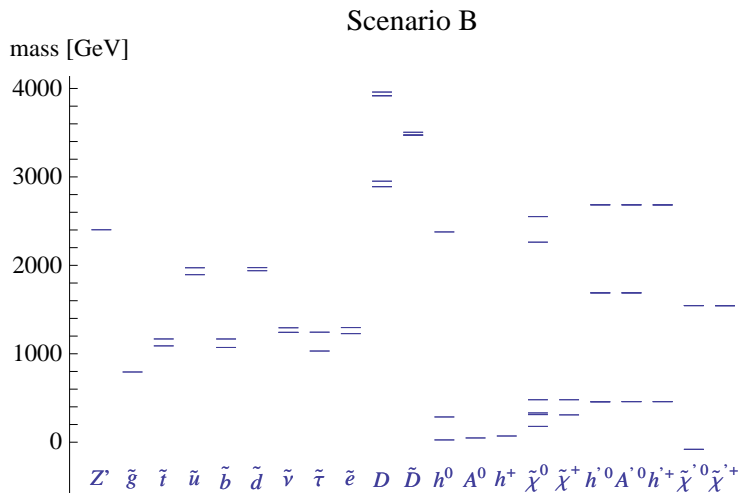

Sample Spectra

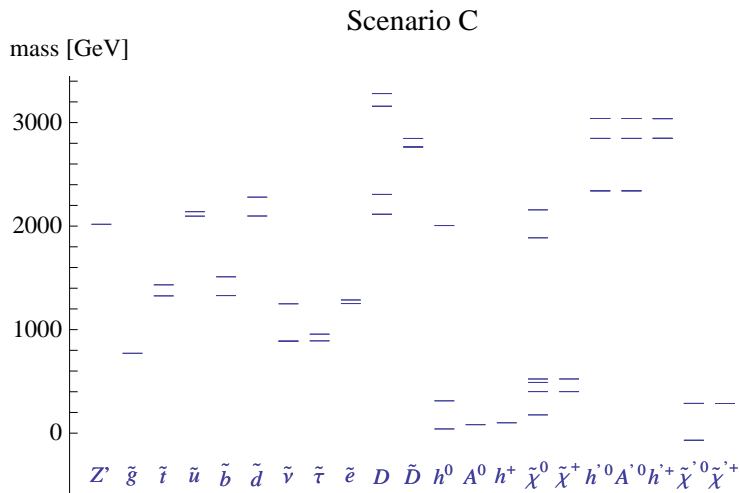

LHC: Search & Model Discrimination

Decay products of heavy particles

- ▶ high- p_T jets, many hard leptons

Production of coloured particles

weakly interacting particles only in decays

Dark Matter \Leftrightarrow **discrete parity** (R, T, KK)

- ▶ new particles only in pairs \Rightarrow high energies, long decay chains
- ▶ Dark Matter \Rightarrow large missing energy in the detector (\cancel{E}_T)

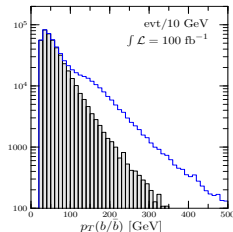

Different models/decay chains — identical signatures

- **Mass of new particles:** endpoints of decay spectra

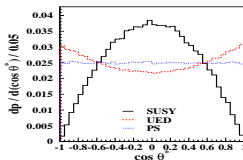
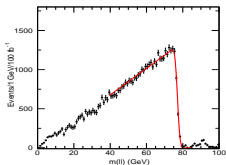

- **Spin of new particles:** Angular correlations, asymmetries, ...
- Model discrimination: **Measuring coupling constants**

LHC: Search & Model Discrimination

Decay products of heavy particles

- ▶ high- p_T jets, many hard leptons

Production of coloured particles

weakly interacting particles only in decays

Dark Matter \Leftrightarrow **discrete parity** (R, T, KK)

- ▶ new particles only in pairs \Rightarrow high energies, long decay chains
- ▶ Dark Matter \Rightarrow large missing energy in the detector (\cancel{E}_T)

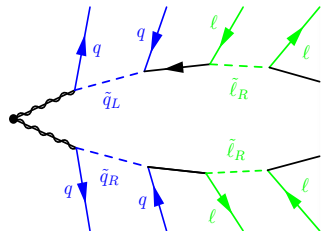

Different models/decay chains — identical signatures

- **Mass of new particles:** endpoints of decay spectra

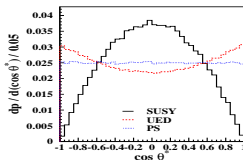
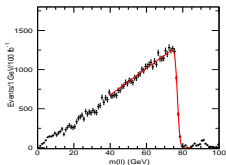

- **Spin of new particles:** Angular correlations, asymmetries, ...
- Model discrimination: **Measuring coupling constants**

LHC: Search & Model Discrimination

Decay products of heavy particles

- ▶ high- p_T jets, many hard leptons

Production of coloured particles

weakly interacting particles only in decays

Dark Matter \Leftrightarrow **discrete parity** (R, T, KK)

- ▶ new particles only in pairs \Rightarrow high energies, long decay chains
- ▶ Dark Matter \Rightarrow large missing energy in the detector (\cancel{E}_T)

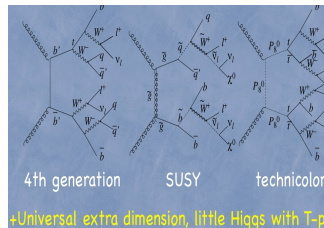

Different models/decay chains — identical signatures

- **Mass of new particles:** endpoints of decay spectra

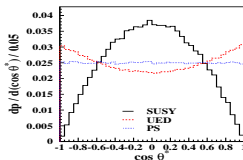
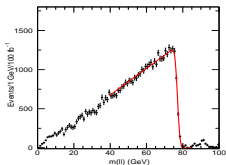

- **Spin of new particles:** Angular correlations, asymmetries, ...
- Model discrimination: **Measuring coupling constants**

WHIZARD

Kilian/Ohl/JRR: DESY/Freiburg/Siegen/Würzburg, hep-ph/0102195, 0708.4233



- ▶ Multi-Purpose event generator for collider and astroparticle physics
- ▶ Acronym: **W**, **H**iggs, **Z**, **A**nd **R**espective **D**ecays (deprecated)
 - ▶ Fast adaptive multi-channel Monte-Carlo integration
 - ▶ Very efficient phase space and event generation
 - ▶ Optimized/-al matrix elements
 - ▶ Recent version: 2.0.7 (19.03.2012)
<http://projects.hepforge.org/whizard> and
<http://whizard.event-generator.org>
 - ▶ Parton shower (k^\perp -ordered and analytical) [Kilian/JRR/Schmidt/Wiesler, JHEP 1204 \(2012\) 013](#)
 - ▶ Underlying Event: preliminary (for 2.1)
 - ▶ Arbitrary processes: matrix element generator (O'Mega)
 - ▶ 2.0 Features: ME/PS matching, cascades, versatile new steering syntax, WHIZARD as shared library
- ▶ Interface to FeynRules [Christensen/Duhr/Fuks/JRR/Speckner, 1010.3215, EPJC \(in print\)](#)
- ▶ Prime example: LHC pheno of HEIDI models [Christensen/Fuks/JRR/Speckner, 1204.6284](#)

WHIZARD

Kilian/Ohl/JRR: DESY/Freiburg/Siegen/Würzburg, hep-ph/0102195, 0708.4233



- ▶ Multi-Purpose event generator for collider and astroparticle physics
- ▶ Focus: LHC, ILC, CLIC, SM, QCD, **BSM**

MODEL TYPE	with CKM matrix	trivial CKM
QED with e, μ, τ, γ	—	QED
QCD with d, u, s, c, b, t, g	—	QCD
Standard model	SM_CKM	SM
SM with anomalous couplings	SM_ac_CKM	SM_ac
SM with anomalous top couplings	—	SM_top
SM with K matrix	—	SM_KM
MSSM	MSSM_CKM	MSSM
MSSM with Gravitinos	—	MSSM_Grav
NMSSM	NMSSM_CKM	NMSSM
extended SUSY models	—	PSSSM
Littlest Higgs	—	Littlest
Littlest Higgs with ungauged $U(1)$	—	Littlest_Eta
Littlest Higgs with T parity	—	Littlest_Tpar
Simplest Little Higgs (anomaly free)	—	Simplest
Simplest Little Higgs (universal)	—	Simplest_univ
UED	—	UED
3-Site Higgsless Model	—	Threshl
Noncommutative SM (inoff.)	—	NCSM
SM with Z'	—	Zprime
SM with Gravitino and Photino	—	GravTest
Augmentable SM template	—	Template

easy to
implement new models

- ▶ Interface to FeynRules [Christensen/Duhr/Fuks/JRR/Speckner, 1010.3215, EPJC \(in print\)](#)
- ▶ Prime example: LHC pheno of HEIDI models [Christensen/Fuks/JRR/Speckner, 1204.6284](#)

Z' : Drell-Yan and Asymmetry

- ▶ Z' , typical mass: 2-2.5 TeV, typical width: ~ 40 GeV
- ▶ Drell-Yan cross section: $\sigma(pp \rightarrow Z' \rightarrow \mu\mu; 14 \text{ TeV}) = 1.5 - 2.5 \text{ fb}$
- Cuts: $|\eta| < 2.5$ (acceptance), $p_T(\mu) > 50 \text{ GeV}$, $M_{\mu\mu} > 1.5 \text{ TeV}$
- Z' line shape; simulation with WHIZARD for 100 fb^{-1} :

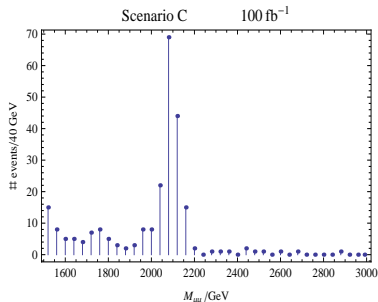
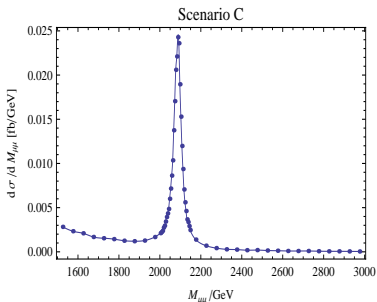

- ▶ **Forward-backward Asymmetry:**
where

$$A_{FB} \equiv \frac{\sigma_F - \sigma_B}{\sigma_F + \sigma_B}$$

$$\sigma_F \equiv \int_0^1 \frac{d\sigma(q\bar{q} \rightarrow \mu^+\mu^-)}{d\cos\theta^*} d\cos\theta^*$$

$$\sigma_B \equiv \int_{-1}^0 \frac{d\sigma(q\bar{q} \rightarrow \mu^+\mu^-)}{d\cos\theta^*} d\cos\theta^*$$

Z' : Drell-Yan and Asymmetry

- ▶ Z' , typical mass: 2-2.5 TeV, typical width: ~ 40 GeV
- ▶ Drell-Yan cross section: $\sigma(pp \rightarrow Z' \rightarrow \mu\mu; 14 \text{ TeV}) = 1.5 - 2.5 \text{ fb}$
- Cuts: $|\eta| < 2.5$ (acceptance), $p_T(\mu) > 50 \text{ GeV}$, $M_{\mu\mu} > 1.5 \text{ TeV}$
- Z' line shape; simulation with WHIZARD for 100 fb^{-1} :

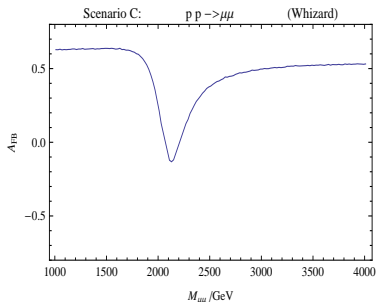
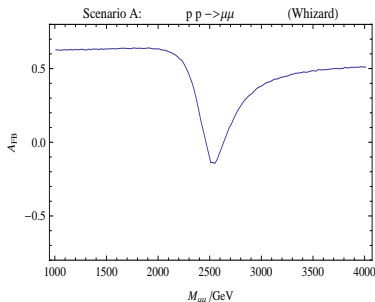

- ▶ **Forward-backward Asymmetry:**
where

$$A_{FB} \equiv \frac{\sigma_F - \sigma_B}{\sigma_F + \sigma_B}$$

$$\sigma_F \equiv \int_0^1 \frac{d\sigma(q\bar{q} \rightarrow \mu^+\mu^-)}{d \cos \theta^*} d \cos \theta^*$$

$$\sigma_B \equiv \int_{-1}^0 \frac{d\sigma(q\bar{q} \rightarrow \mu^+\mu^-)}{d \cos \theta^*} d \cos \theta^*$$

Predictions from E_6 GUTs for LHC

Braam/JRR/Wiesler, 0909.3081

- ▶ Simulations for the E_6 model with WHIZARD
- ▶ Implementation of Leptoquark/Leptoquarkino + Higgs/weak ino sector (now FeynRules impl.)
- ▶ **Analyses:** BRs, cross sections for scalar leptoquarks, S/B
- ▶ Leptoquarkino phenomenology

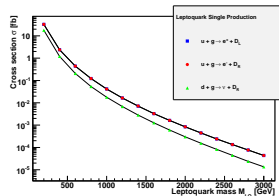
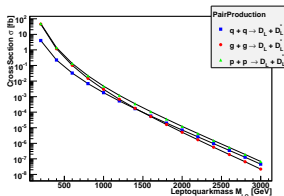
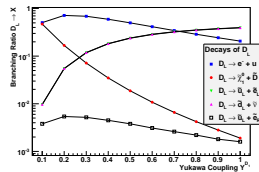

Cuts		Background	$m_D = 0.6$ TeV		$m_D = 0.8$ TeV		$m_D = 1.0$ TeV	
p_T	$M_{\ell\ell}$	N_{BG}	N_1	S_1/\sqrt{B}	N_2	S_2/\sqrt{B}	N_3	S_3/\sqrt{B}
50	10	413274	64553	93	14823	23	4819	7
100	150	3272	40749	194	10891	92	3767	45
200	150	198	12986	113	5678	74	2405	47

Predictions from E_6 GUTs for LHC

Braam/JRR/Wiesler, 0909.3081

- ▶ Simulations for the E_6 model with WHIZARD
- ▶ Implementation of Leptoquark/Leptoquarkino + Higgs/weak ino sector (now FeynRules impl.)
- ▶ **Analyses:** BRs, cross sections for scalar leptoquarks, S/B
- ▶ Leptoquarkino phenomenology

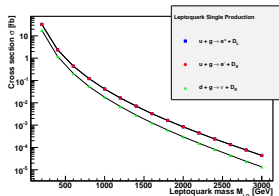
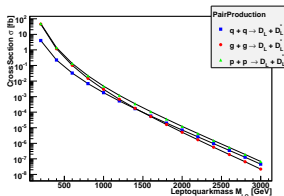
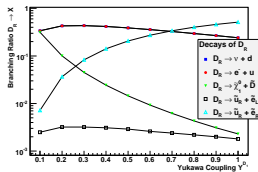

Cuts		Background	$m_D = 0.6$ TeV		$m_D = 0.8$ TeV		$m_D = 1.0$ TeV	
p_T	$M_{\ell\ell}$	N_{BG}	N_1	S_1/\sqrt{B}	N_2	S_2/\sqrt{B}	N_3	S_3/\sqrt{B}
50	10	413274	64553	93	14823	23	4819	7
100	150	3272	40749	194	10891	92	3767	45
200	150	198	12986	113	5678	74	2405	47

Braum/JRR/Wiesler, 0909.3081; Braam/Horst/Knochel/JRR/Wiesler, 2010/11

Invariant mass of lepton and jet

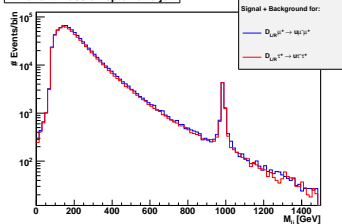

Invariant mass of lepton and jet

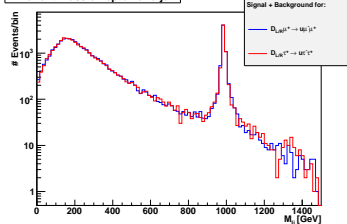
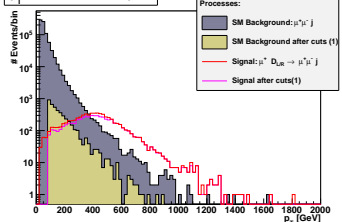
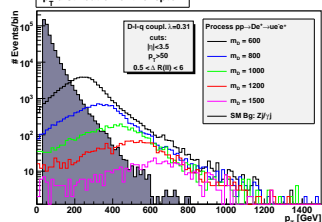
 p_T distribution of the lepton p_T distribution of the lepton

- Backgrounds: $tt + n_j, W/Z + n_j$
- Cuts: $p_T > 150$ GeV, $-1.0 < \cos \theta_{lj} < 0.7$

Mass Edges for Leptoquarkinos

JRR/Wiesler, 1010.4215

► Properties of Leptoquarkinos:

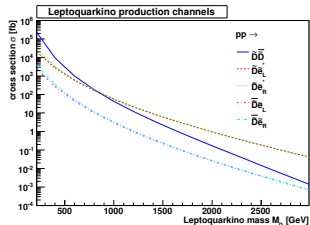
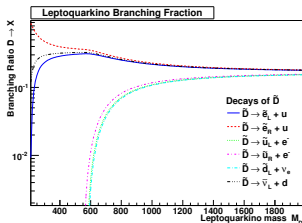

► Identical exclusive final states

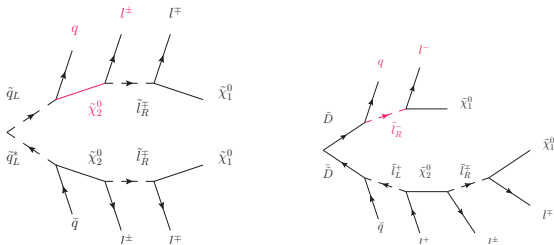

Mass Edges for Leptoquarkinos

JRR/Wiesler, 1010.4215

- Mass edges more dominant because of missing spin correlations

$$m_{ql,high} = \max\{m_{ql+}, m_{ql-}\} \quad m_{ql,low} = \min\{m_{ql+}, m_{ql-}\}$$

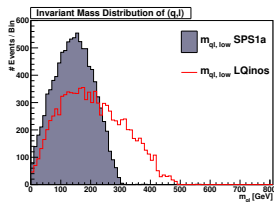
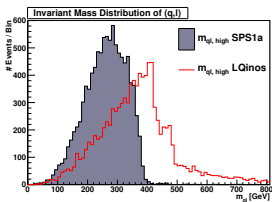

- Combinatorial backgrounds, combine softest jet and hardest lepton:

$$m_{ql}^* = m(\min_E\{q_1, q_2\}, \max_E\{l^+, l^-\})$$

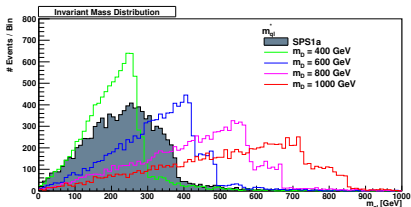

Discrimination from standard SUSY

JRR/Wiesler, 2010/11

- Look at dilepton spectrum: standard SUSY \Rightarrow same cascade, Leptoquarkinos \Rightarrow different cascades
- Cut on kinematic edge in standard dilepton spectra

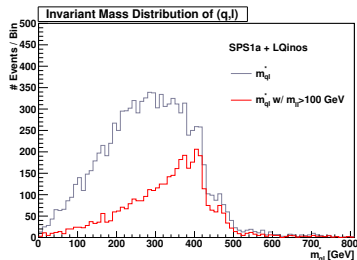
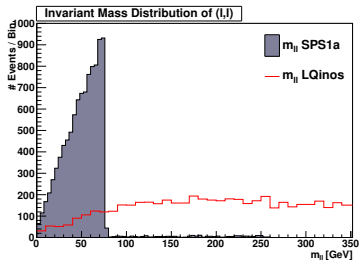

- S/B estimate, 100 fb^{-1} , 2 OSSF, 2 hard jets, \cancel{E}_T

$m_{\tilde{D}}$	# N(LQino) & N(SUSY)	# N_{cut}	$S / \sqrt{S+B}$
400	8763	5061	54
600	1355	540	15
800	684	102	4
1000	594	24	1

- More pheno to come..... stay tuned...

Proton Decay in the PSSSM

Mallot/JRR, 2010

- Superpotential (and soft breaking) do not induce proton decay
- Investigate exchange of E_6 gauge bosons/gauginos
- Steps from top down:
 1. Group-theoretical weights from Clebsch-Gordan decomposition
Horst/Mallot/JRR, 2009
 2. Calculation of proton-decay Wilson coefficients at Λ_{GUT}
 3. Short-distance (SUSY) renormalisation group factor
 4. Matching to SM dimension-6 Fermi operators
 5. Long-distance (SM/QCD) renormalisation group factor
 6. Matching to mesonic/baryonic operators (analogue to chiral perturbation theory)
 7. Calculation of baryon decay matrix element and width
- Yields **very conservative estimate**:

$$1/\Gamma_{tot}(p \rightarrow X) \approx 10^{40} - 10^{46} \text{ Jahre}$$

Summary SUSY GUTs

- Grand Unified Theories with intermediate breaking
- Viable scenarios: $E_6 \rightarrow SU(3/4) \times SU(2)_L \times SU(2)_R \times U(1)^2$
- Possible breaking mechanisms: Higgs vs. Orbifold boundary conditions
- Proton decay beyond experimental reach
- Direct hints through chiral exotics at LHC
- Interesting, but intricate phenomenology at LHC
- Embedding into heterotic string/F theory (if someone is interested)
- Flavour plays important role: continuous vs. discrete symmetries
- Open questions: flavour, dark matter, SUSY breaking mechanisms

Outlook

- LHC: new era of physics
- New particles, new symmetries, new interactions, dark matter
- Model Building, Phenomenology, Tools
- Interesting times!

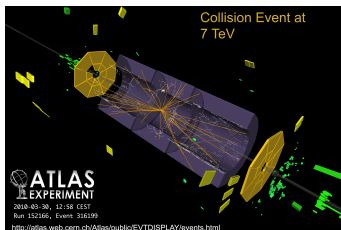

Outlook

- LHC: new era of physics
- New particles, new symmetries, new interactions, dark matter
- Model Building, Phenomenology, Tools
- Interesting times!

LHCb Event Display

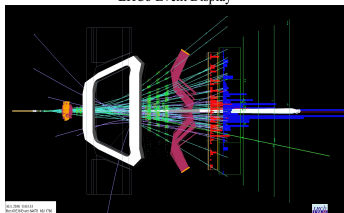

Outlook

የአዎንታዊ ልዩ ልዩ ስርዓት ለማግኘት

- LHC: new era of physics
- New particles, new symmetries, new interactions, dark matter
- Model Building, Phenomenology, Tools
- **Some Unification Needs Time**

*"Though this be madness, yet there is method in 't." -
(Hamlet, Act II, Scene II).*

Outlook

የአዲስ ድንገተኛ ምርመራ ለ ከጋራ ጥናት።

- LHC: new era of physics
- New particles, new symmetries, new interactions, dark matter
- Model Building, Phenomenology, Tools
- **Some Unification Needs Time**



*"Though this be madness, yet there is method in 't." -
(Hamlet, Act II, Scene II).*