

# RF AND BEAM DYNAMICS CONSIDERATIONS FOR THE CAVITY END GROUP OF THE ALL SUPERCONDUCTING DESY GUN\*

Dmitry Bazyl, Daniel Klinke, Jan-Hendrik Thie, Elmar Vogel, DESY, Hamburg, Germany

## Abstract

Future high duty cycle (HDC) operating modes are under development for the European XFEL. An L-band superconducting RF (SRF) gun is foreseen as the injector operating continuous wave (CW). To preserve the small beam emittance distracting effects like RF kicks from the power coupler, trapped higher order modes (HOMs) in the cavity end group and RF field asymmetries need to be considered and countermeasures to be taken. Apart from the beam dynamics, the feasibility and effort of the manufacturing and surface treatment, the later assembly and operation needs likewise consideration. In our contribution we present the outcome of our studies and the cavity end group which will be realized at our next prototype cavities.

## INTRODUCTION

A future upgrade of the European XFEL foresees HDC operation ranging from CW and 100% duty-cycle giving maximum flexibility for the laser pulse timing to about 8% duty-cycle for high energy electrons send to the undulator sections. This requires a photoinjector operating continuous wave CW. A high gradient L-band SRF gun [1] is the first choice. It will enable "pancake" emission of beams and direct matching into the subsequent linac [2]. In recent years we managed to establish surface treatment procedures of our 1.6-cell SRF gun cavities resulting in typical maximum peak field on axis gradients of about 55 MV/m [3] providing sufficient margin to the design value of 40 MV/m. Next R&D steps foresee work on photocathodes robust against SRF cleaning procedures, the integration of the cavities into helium vessels, cavity tuners, a cryostat. We also focus on construction of an SRF photoinjector test stand to study the complete setup and the properties of the beam produced. In view of all the design work on the surrounding structures and the later use in the test stand and also in the XFEL CW injector the cavity end group required now attention to preserve the beam quality.

In this work, electromagnetic (EM) field simulations have been carried out using CST Studio® [4]. Particle tracking code REptil (Particle Tracker for Injectors and Linacs) [5] developed at TEMF [6] has been implemented for beam dynamics simulations: among other features, the code allows for the calculation of the 3D space charge during emission from the cathode.

## FUNDAMENTAL POWER COUPLER

The standard fundamental power coupler (FPC) used for 9-cell TESLA cavities at DESY [7] needs to be modified

\* Work performed in the framework of R&D for future accelerator operation modes at the European XFEL and financed by the European XFEL GmbH.

for the CW SRF gun. In order to attain the design value of the external quality factor  $Q_{\text{ext}}$  of  $4 \cdot 10^7$  for the fundamental mode, the inner conductor of the standard FPC will be shortened by 20 mm. The geometry of the CW SRF gun including the adapted FPC is illustrated in Fig. 1.

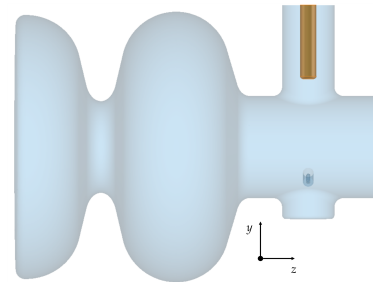

Figure 1: Layout of the next generation DESY CW/HDC L-band SRF gun.

The position of the inner antenna can be adjusted vertically within a  $\pm 10$  mm range from the reference location. Figure 2 indicates the tuning range of the modified FPC in terms of numerically computed values of  $Q_{\text{ext}}$ . The penetration depth of 0 mm (reference position) corresponds to the distance of 51.75 mm between the antenna tip and the central axis of the cavity.

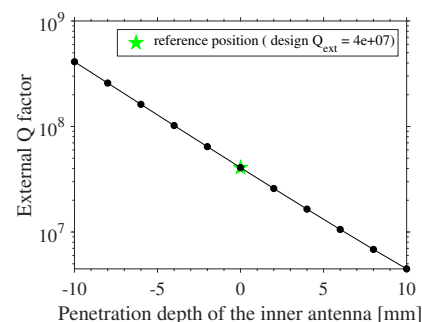

Figure 2: Numerically computed external  $Q$  factor as a function of the variation in penetration depth of the inner antenna of the FPC with respect to the reference position.

## Compensating Stub

The geometry of the end-group of the SRF gun is not axially symmetric. Therefore, the symmetry of the electromagnetic field distribution in the FPC region is an important consideration. The transverse electric field on the cavity's axis can lead to transverse emittance dilution. In order to minimize the negative impact, a compensating stub solution similar to [8] has been proposed and optimized [9].

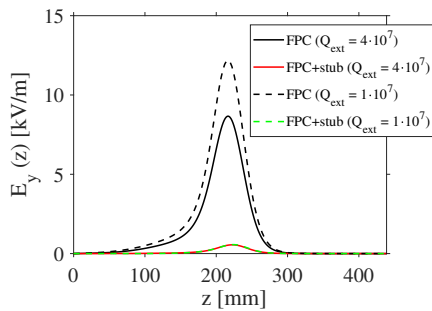

Figure 3: Transverse electric field distribution on the central axis of the cavity (TM010,  $\pi$ -mode; amplitude normalized to 1 J stored energy).

Figure 3 shows the distribution of the transverse electric field  $E_y$  as a function of the longitudinal coordinate  $z$ . Each scenario (with and without the compensating stub) is considered for the nominal value of  $Q_{\text{ext}}$ , as well as for a second option where stronger coupling is implied with  $Q_{\text{ext}}$  of  $1 \cdot 10^7$ . The analysis of the coupler kick's influence on beam dynamics in the SRF gun is a complex subject that extends beyond the scope of this paper. Factors to consider include the non-relativistic electron beam with a notable change of velocity in the full cell, the presence of the focusing solenoid, the potential for dynamic detuning of the cavity (e.g., due to microphonics), and the presence of mechanical production errors in the SRF cavity. A fifteen-fold reduction in the transverse electric field amplitude at the cavity's axis, achieved using the stub at the nominal value of  $Q_{\text{ext}}$ , offers a convincing argument for its implementation.

In order to illustrate the compensating effect on the beam quality, particle tracking has been carried out implementing a 3D field map of the SRF gun, including the FPC with penetration depth of the inner antenna corresponding to  $Q_{\text{ext}}$  of  $1 \cdot 10^7$ . For this qualitative example, the lattice consists the SRF gun with the peak electric field on axis of 50 MV/m, followed by the focusing solenoid and the booster (8 TESLA cavities), both represented with axially symmetric fields. Figure 4 indicates the resulting beam distribution at the booster's exit: gun cavity without coupler kick compensation (left) and with the compensating stub (right). In the presence of the kick, the least squares fit line (black) indicates a tilt of the bunch, quantifiable by the angle of incline  $\theta$ . Without coupler kick compensation,  $\theta=0.4^\circ$ ; while the compensating stub implementation reduces  $\theta$  to  $0.02^\circ$ . For both cases, a number of factors can further amplify the negative impact of the coupler kick (e.g., mechanical tolerance, RF phase offset of the gun, dynamic cavity detuning).

## HIGHER ORDER MODES

Compared to 9-cell TESLA cavities, the DESY CW SRF gun does not incorporate a direct mechanism to suppress HOMs. Integrating the HOM coupler for the gun cavity in the same way as for the 9-cell cavities [10] would cause

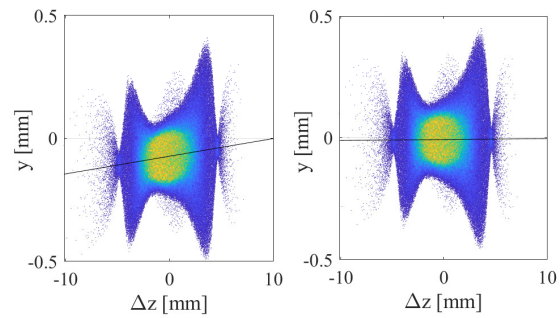

Figure 4: Transverse electric field distribution on the central axis of the cavity (TM010,  $\pi$ -mode; amplitude normalized to 1 J stored energy).

EM field asymmetry in the FPC region and complicate the assembly.

We have performed eigenmode analysis in the frequency range from 1.6 GHz to 2.5 GHz with the aim to identify and characterize potentially dangerous HOMs. The Lossy Eigenmode Solver is used in CST Studio® since it allows to consider RF losses and directly computes a loaded  $Q$  factor for each calculated mode (e.g. due to resistive losses, radiated losses or  $Q_{\text{ext}}$ ). The RF model consists of the SRF gun cavity with perfect electric conductor defined as background material followed by a meter long copper tube starting at 105.6 mm from the end-cell. In order to take into account coupling of HOMs to the FPC, the corresponding port is implemented. The loaded  $Q$  factor is defined as

$$Q_L = 2\pi f \frac{U}{P_t}, \quad (1)$$

where  $f$  is the resonance frequency,  $U$  is the stored energy, and  $P_t$  is the total dissipated RF power.

Another useful figure of merit for the analysis is  $R/Q$  (2): longitudinal  $R/Q_{\parallel}$  and transverse  $R/Q_{\perp}$ :

$$\frac{R}{Q_{\parallel}} = \frac{1}{2\pi f} \frac{V_{\parallel}^2}{U}, \quad \frac{R}{Q_{\perp}} = \frac{1}{2\pi f} \frac{V_{\perp}^2}{U}, \quad (2)$$

where  $V_{\parallel}$  and  $V_{\perp}$  is the longitudinal and transverse voltage respectively.

Figure 5 indicates the resonant frequencies and the corresponding values of  $(R/Q) \cdot Q_L$  of four HOMs, which are identified as potentially dangerous due to relatively high values of  $R/Q$  and  $Q_L$ . The first three of them are dipole modes (two polarizations considered) and the last one is a monopole mode. The dipole modes are trapped in the gun cavity. Despite relatively low bunch charge of 100 pC, the resonant excitation of the dipole HOMs can degrade the transverse beam quality. Damping of dipole HOMs in this frequency range can be achieved by increasing the beam tube diameter from 78 mm to 106 mm and by utilizing a four-meter long drift space in the copper beam tube following the connecting flange of the cavity. We abandoned this idea at the early stage because it requires re-qualification of the production

process of the full-cell to beam pipe connection delaying the gun R&D schedule.

One additional monopole mode which requires careful attention is the 0-mode of the fundamental passband. It can be induced by the beam and it is characterized by relatively high  $R/Q_{\parallel}$  value of 40 Ohm with  $Q_L$  at the level of  $8 \cdot 10^7$ . Excitation of this mode must be avoided due to its negative impact on the longitudinal emittance (energy spread).

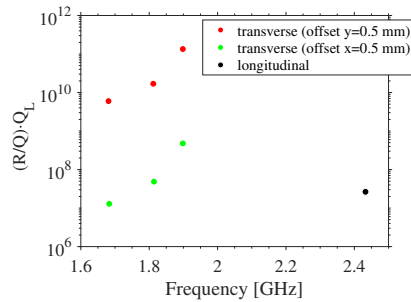

Figure 5: Potentially dangerous HOMs in the frequency range from 1.6 to 2.5 GHz.

In absence of active HOM damping, the approach to managing HOMs in the SRF gun involves minimizing beam deviation from the central axis to avoid dipole modes excitation: implementing a high-precision positioning system for the gun cavity, and adjusting laser position at the cathode. For monopole modes, resonant frequencies of HOMs can be prevented from intersecting the beam frequency spectra by adjusting the beam repetition rate accordingly or by controlled frequency detuning. Dynamic frequency detuning (e.g., due to microphonics) and narrow resonance bandwidth of the dipole HOMs due to high  $Q_L$  values (trapped modes) further reduce probabilities of the resonant excitation.

One of the key aspects of the chosen strategy is monitoring HOMs during operation. A potential option in our specific case is to analyze the signal originating from the pick-up (PU) antenna. A simple qualitative experiment at FLASH [11] demonstrated the possibility of detecting dipole HOMs (namely, two modes in the passband of TE111) using the RF signal from the PU antenna of one of the 9-cell cavities in the main linac and analyzing it using Spectrum analyzer (SA) (see Fig. 6). Remarkably, these signals were acquired without the utilization of RF signal amplifier. This is noteworthy considering  $\sim 100$ -meter cable length between PU antenna and the SA and unavoidable presence of the 3 dB RF power splitter in the transmission line.

## PICK-UP ANTENNA

The positioning of the standard PU antenna (see Fig.7) is determined by considering three factors: establishing weak coupling for the fundamental mode ( $Q_{\text{ext}} = 1.7 \cdot 10^{11}$ ), detecting and monitoring HOMs with various polarizations, and meeting the assembly requirements in the clean room. HOM monitoring is planned by utilizing an independent LLRF interface that requires development.

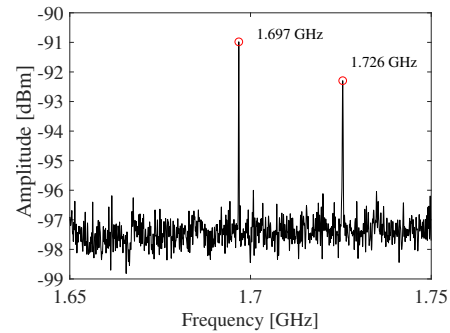

Figure 6: Spectrum analyzer output displaying two distinct peaks at the noise level, corresponding to two modes in the passband of TE111.

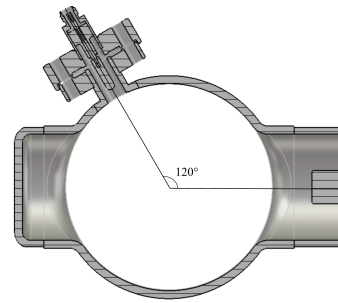

Figure 7: Alignment of the PU antenna.

Assuming that the operating value of the peak electric field on axis will be in the range from 40 to 60 MV/m the expected power to be extracted via PU is within 0.5 and 1 W whereas the thermal limit is approximately 5 W [12].

## CONCLUSION

The modified design of the FPC for the CW SRF gun is effective in achieving the necessary external  $Q$  factor in the available tuning range. Implementation of the compensating stub allows to significantly minimize the negative impact of the coupler kick. Although the HOM suppression is absent, monitoring and avoiding HOM excitation during operation remains a viable solution. The position of the pickup antenna has been adjusted to achieve weak coupling with the fundamental mode and allow HOM monitoring. These changes will be implemented for our next prototype gun cavities.

## ACKNOWLEDGEMENTS

We would like to express our gratitude to Jacek Sekutowicz, Hans Weise, Detlef Reschke and Denis Kostin for valuable inputs and discussions concerning various RF/SRF aspects of this work.

We thank Nicoleta Baboi, Julien Branlard, Matthias Hoffmann for their key role in carrying out measurements concerning HOM detection in TESLA cavities via PU antenna at FLASH. Finally, we thank FLASH team for making measurements possible.

## REFERENCES

- [1] J. S. Sekutowicz *et al.*, “Nb-Pb Superconducting RF-Gun”, in *Proc. EPAC’06*, Edinburgh, UK, Jun. 2006.
- [2] H. Qian and E. Vogel, “Overview of CW RF Guns for Short Wavelength FELs”, in *Proceedings of FEL2019, Hanburg, Germany*, 2019. doi:10.18429/JACoW-FEL2019-WEA01
- [3] E. Vogel *et al.*, “Surface Treatment Experience of the All Superconducting Gun Cavities”, in *Proceedings of IPAC2023, Venice, Italy, 2023*. doi:10.18429/JACoW-IPAC2023-WEPA145
- [4] CST Studio Suite®. <https://www.3ds.com/de/produkte-und-services/simulia/produkte/cst-studio-suite/>
- [5] E. Gjonaj, *Reptil – status of development and overview of capabilities*, Presentation, 2022. [https://www.desy.de/xfel-beam/s2e/talks/2022\\_01\\_11/EG.pdf](https://www.desy.de/xfel-beam/s2e/talks/2022_01_11/EG.pdf)
- [6] TU Darmstadt, TEMF. <https://www.temf.tu-darmstadt.de/temf/index.en.jsp>
- [7] W.-D. Möller, “High Power Coupler for the TESLA Test Facility”, in *Proc. SRF’99*, Santa Fe, NM, USA, Nov. 1999, pp. 577–581. <https://jacow.org/SRF99/papers/THA010.pdf>
- [8] B. Buckley and G. H. Hoffstaetter, “Transverse emittance dilution due to coupler kicks in linear accelerators”, *Phys. Rev. ST Accel. Beams*, vol. 10, p. 111 002, 11 2007. doi:10.1103/PhysRevSTAB.10.111002
- [9] A. Sulimov, *Private communication*.
- [10] B. Aune *et al.*, “Superconducting tesla cavities”, *Phys. Rev. ST Accel. Beams*, vol. 3, p. 092 001, 9 2000. doi:10.1103/PhysRevSTAB.3.092001
- [11] DESY, Free-Electron Laser FLASH. [https://www.desy.de/research/facilities\\_\\_projects/flash/index\\_eng.html](https://www.desy.de/research/facilities__projects/flash/index_eng.html)
- [12] D. Kostin, *Private communication*.