

Start-To-End Simulations for the European XFEL

Martin Dohlus, Igor Zagorodnov

- description of European XFEL beam line
- technical aspects of simulation
 - matching / codes / tools
- gun
- μ -bunch “instability”
 - laser heater / technical aspects of simulation
- European XFEL – segmentation (for simulation)
- method 1 (fast)
- method 2 (reference)
- method 3 (efficient & accurate) – to be done

European XFEL, description, s2e home page

Address <http://www.desy.de/xfel-beam/>

European XFEL Beam Dynamics Group Home Page

[MAD file](#) [List Of Components](#)

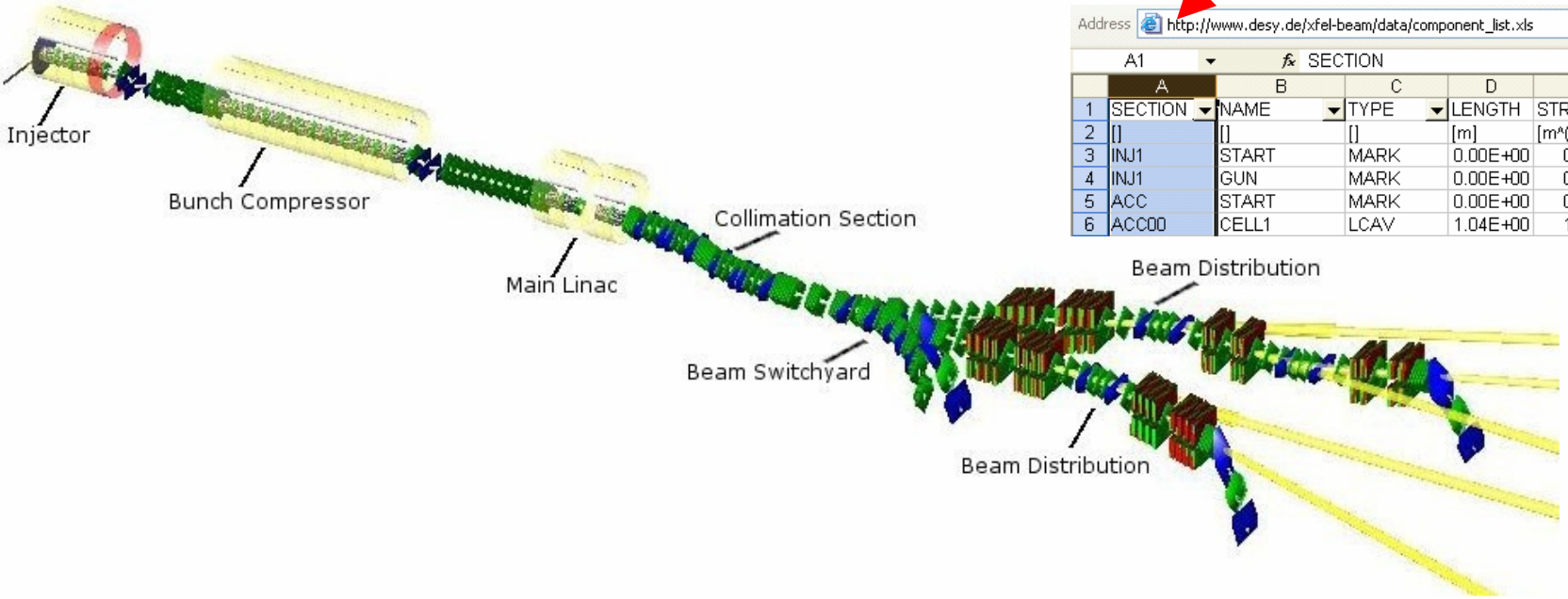

Injector Bunch Compressor Main Linac Collimation Section Beam Switchyard Beam Distribution

Address http://www.desy.de/xfel-beam/data/component_list.xls

A1	SECTION	A	B	C	D	E	I
1	SECTION	NAME	TYPE	LENGTH	STRENGTH	E1/I	
2	[]	[]	[]	[m]	[m ⁿ (1-n)/MV]	[rad]	
3	INJ1	START	MARK	0.00E+00	0.00E+00	0.0	
4	INJ1	GUN	MARK	0.00E+00	0.00E+00	0.0	
5	ACC	START	MARK	0.00E+00	0.00E+00	0.0	
6	ACC00	CELL1	LCAV	1.04E+00	1.05E+01	0.0	

click in the picture to go to the descriptions of the single parts

[Papers, Talks, Meetings](#) [Start-to-End Simulations](#) [XFEL Project Website](#) [Links and Codes](#)

s2e simulation: technical aspects

rf settings: phase and amplitude settings are very sensitive
wakes & space charge effects change longitudinal
profile significantly!
→ iterative optimization

matching: real
artificial

steering

bunch: 1nC, ~50A (initial)

simulation: s2e particles (ASTRA-generator & gun simulation)

$N_{s2e} \approx 200000$

try to track these particles; avoid conversions to
other distributions (if possible);

simulation tools

ASTRA: on-axis-tracking, rz-space charge, rf, magnets,
no wakes

CSRtrack: non-linear motion effects,
1d CSR model, sub-bunch models

GENESIS: time dependent 3d FEL code

ELEGANT: rf, magnets, wakes,
no space charge, 1d CSR model

utility programs

format conversion: ASTRA / CSRtrack / sdds

some simple manipulations of longitudinal phase space:

- add cavity wakes (based on point particle wakes,
asymptotic fit to ECHO calculations),
- add space charge wakes (semi analytic model)

some simple manipulations of transverse phase space:

(transport matrices)

- drift,
- transport as defined by linear optics (design),
- matching

ASTRA: rz space charge model

3d: slices & centroids

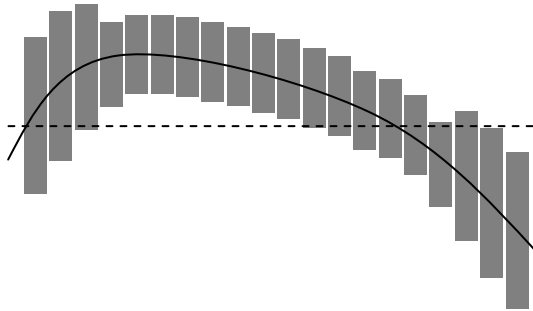

ASTRA rz-model for s.c. calculation

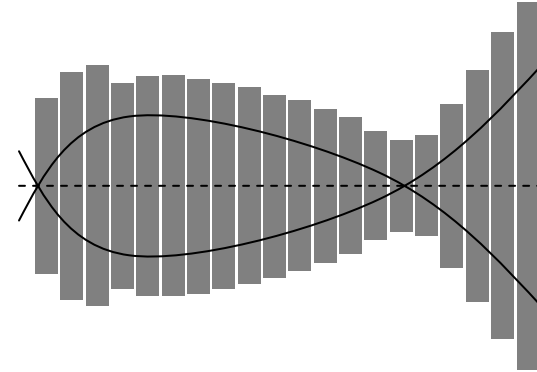

charge density is underestimated

1) extract centroid offsets

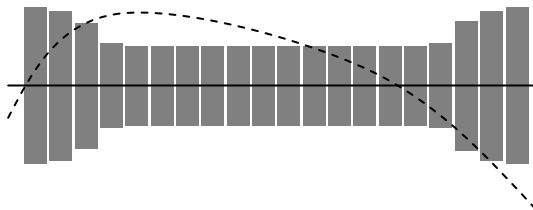

- 2) ASTRA tracking of particles with extracted centroid offsets
- 3) transport centroid offsets (matrix)
- 4) restore new particle coordinates (add centroid offset)

remark: 3d space charge models create more noise (or need more particles)

CSRtrack

projected or 1d-CSR model:

particles distribution \rightarrow smooth 1d current \rightarrow 1d longitud. field \rightarrow particle energy
low numerical effort

sub-bunch model:

- 1) create distribution of 'generating' 3d-sub-bunches
 $N_g \approx 100000; (x, x', y=0, y'=0, z, p_z, q)$
- 2) combine s2e-particles and 'generating' bunches
- 3) set charges of s2e-particles in combined distribution to zero
- 4) CSRtrack: self consistent tracking
 $\sim 10^1$ h on linux cluster with 20 cpu-s (64bit)
- 5) extract coordinates of s2e particles

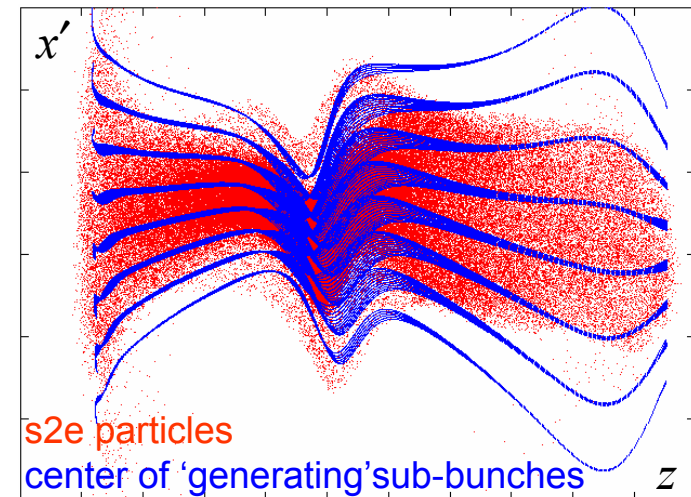

projected vs. sub-bunch:

1d model sufficient for centroid motion & projected emittance;
XFEL: slice effects are weak;
uncorr. energy spread dominated by laser heater

semi analytic space charge model

steady state space charge impedance:

$$\mathbf{E}(x, y, z, k) = \mathbf{E}(x, y, k, \sigma_r, R_{pipe}, \gamma) \cdot \exp(-ikz)$$

R_{pipe} = radius of beam pipe
 σ_r = rms width of round gaussian beam
 γ = Lorentz factor

$$Z'_{sc}(k, \sigma_r, R_{pipe}, \gamma) = \frac{\int \mathbf{u}_z \cdot \mathbf{E}(x, y, k, \sigma_r, R_{pipe}, \gamma) \psi(x, y) dx dy}{\int \psi(x, y) dx dy}$$

$\psi(x, y)$ = transverse profile (round, rms width σ_r)

e.g. free space, $k\sigma_r/\gamma \ll 1$: $Z'_{sc}(k, \sigma_r, R_{pipe}, \gamma) \approx \frac{iZ_0 k}{2\pi\gamma^2} \ln\left(\frac{\gamma}{k\sigma_r}\right)$

$$Z_{sc}(k, a \rightarrow b) = \int_a^b Z'_{sc}(k, \sigma_r(z), R_{pipe}, \gamma(z)) dz$$

with:

$$\sigma_r(z) = \sqrt{\frac{\epsilon_n}{\gamma(z)} \beta_{twiss}(z)}$$

ϵ_n = normalized design emittance

$$\beta_{twiss}(z) \approx \sqrt{\frac{\beta_x(z)^2 + \beta_y(z)^2}{2}}$$

β_x, β_y = beta function

gun

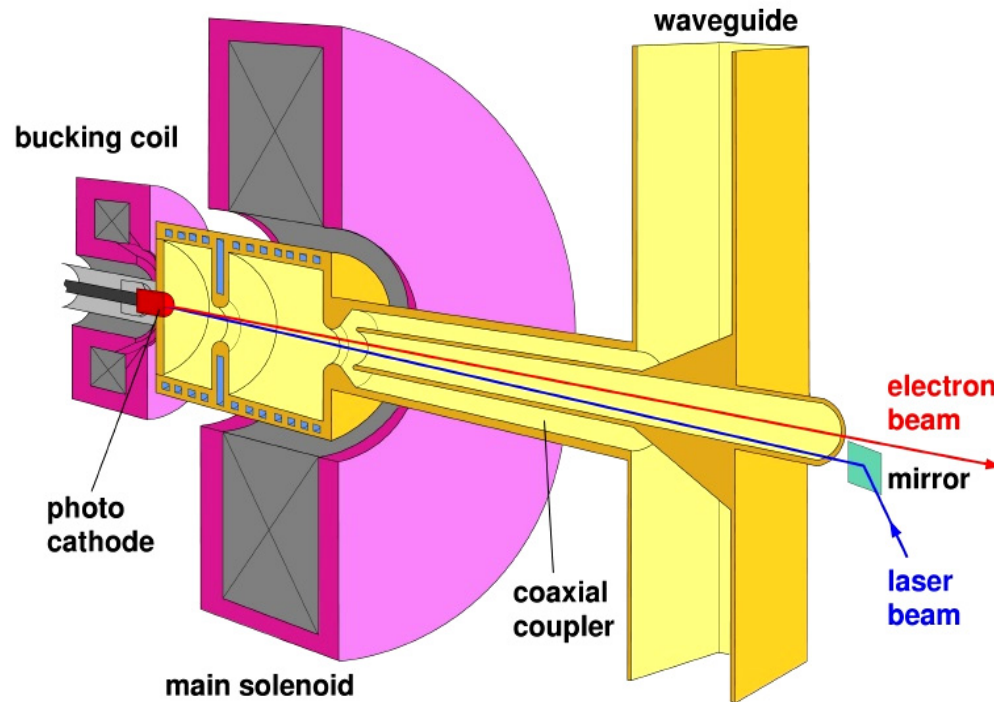

ASTRA simulation

“black box”

(ASTRA input from K.Flöttmann)

1nC, 200000 particles

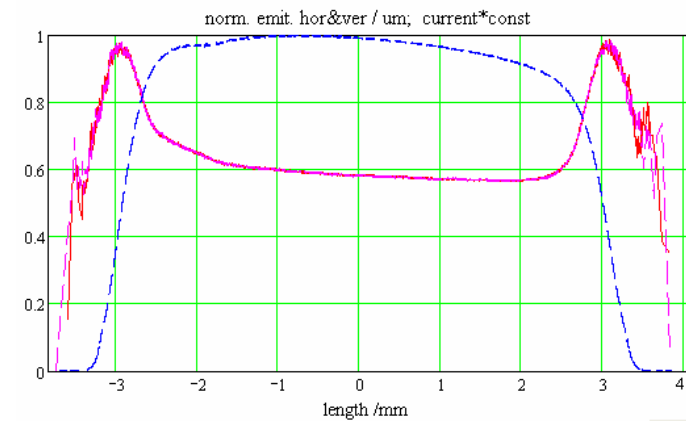
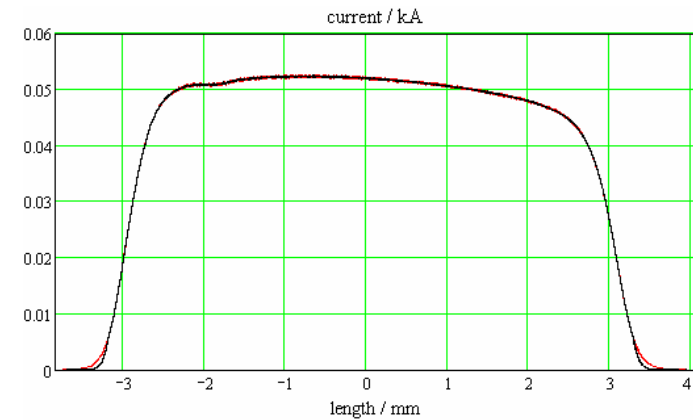

energy-offset correlation after gun

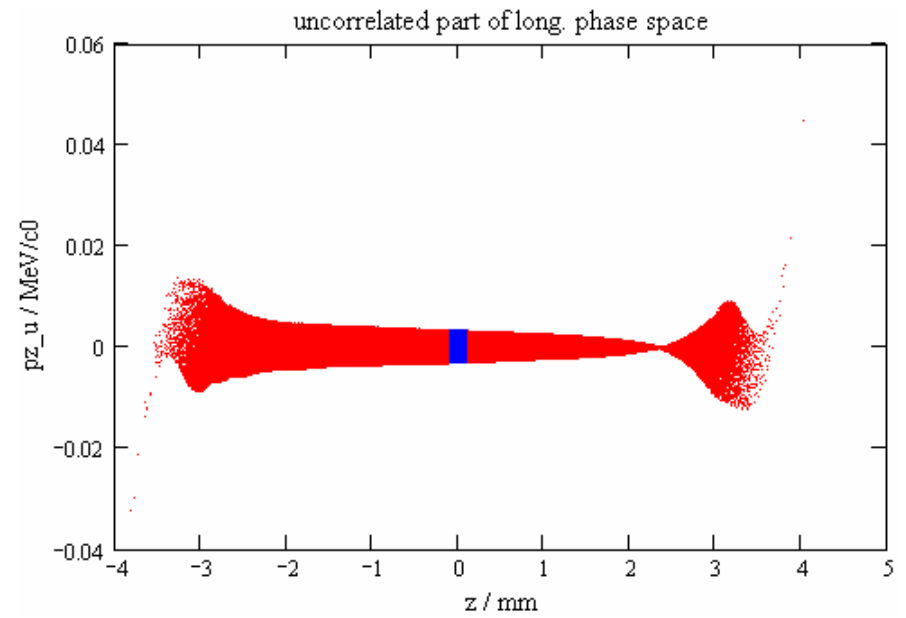
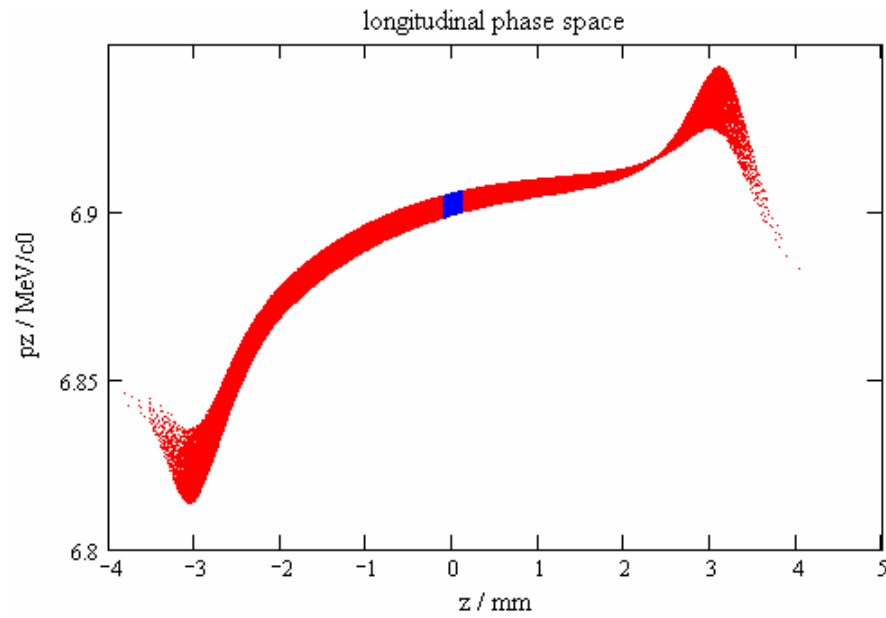

energy-offset correlation
1m after cathode

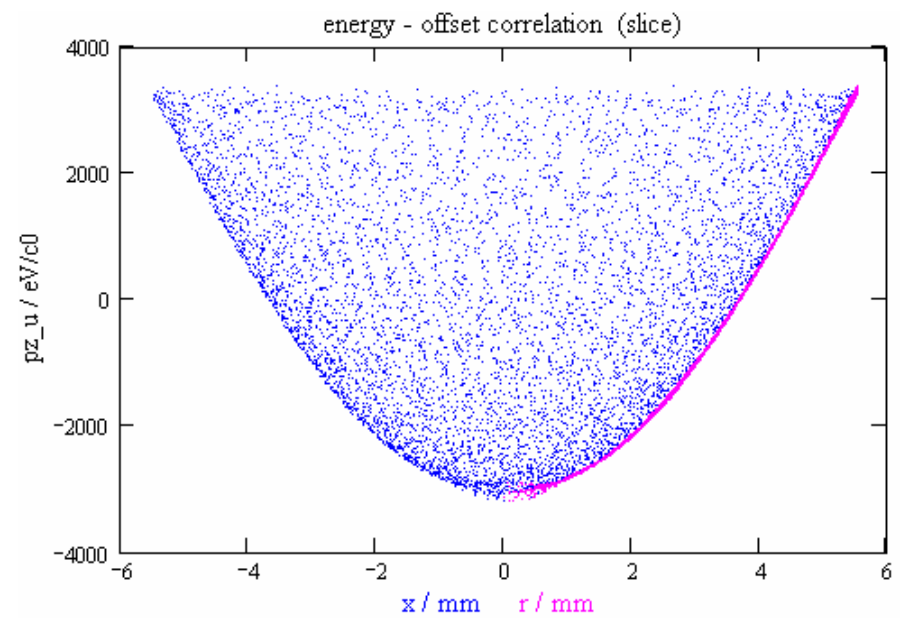

energy-offset correlation

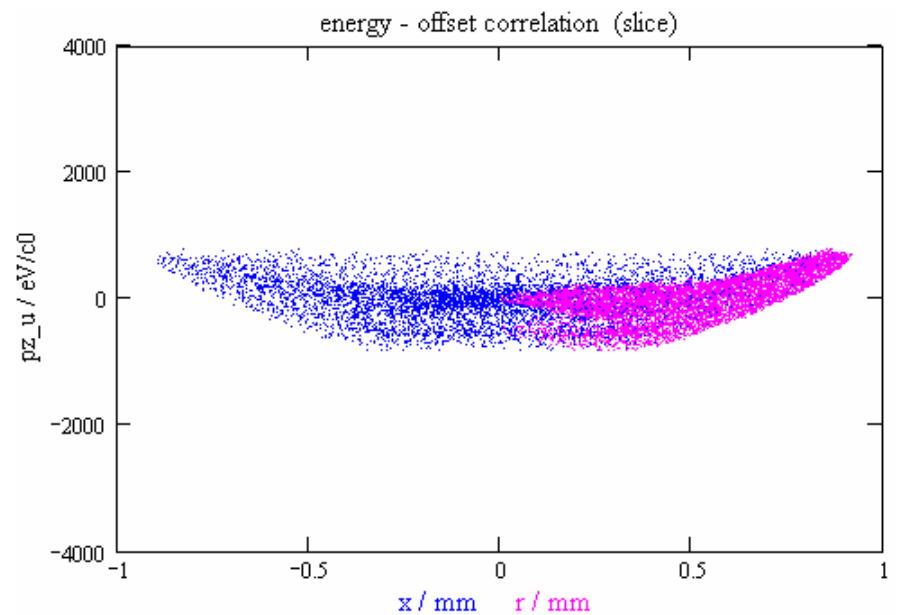
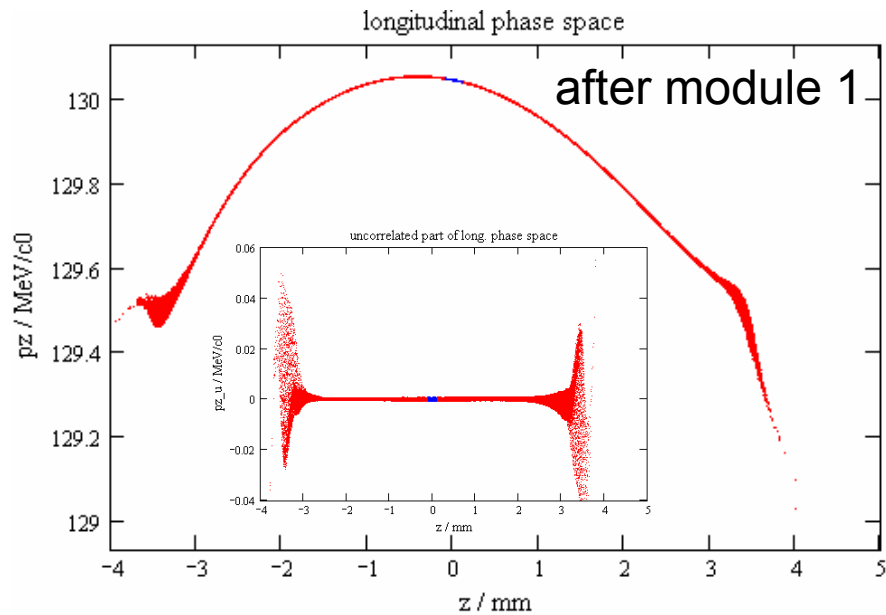
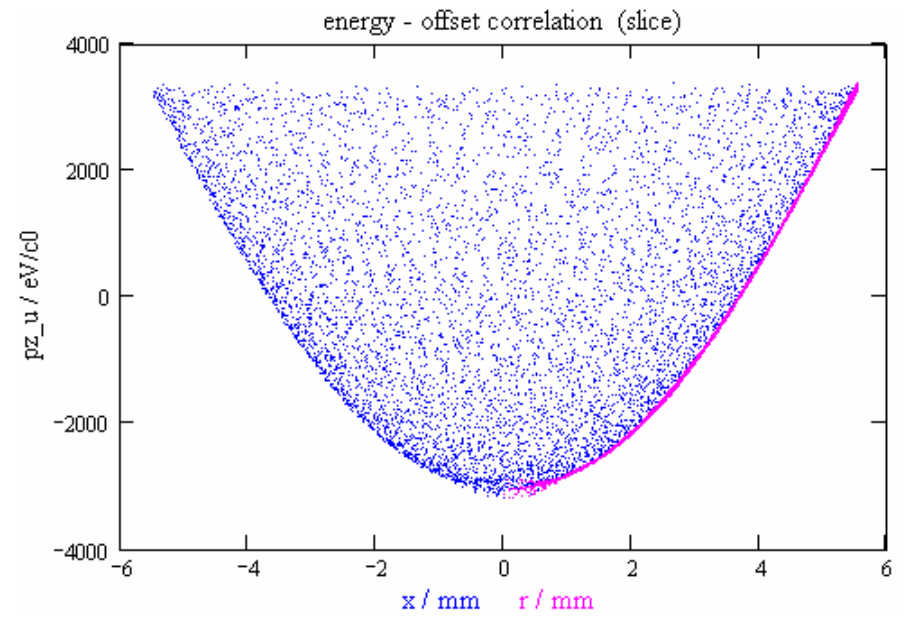
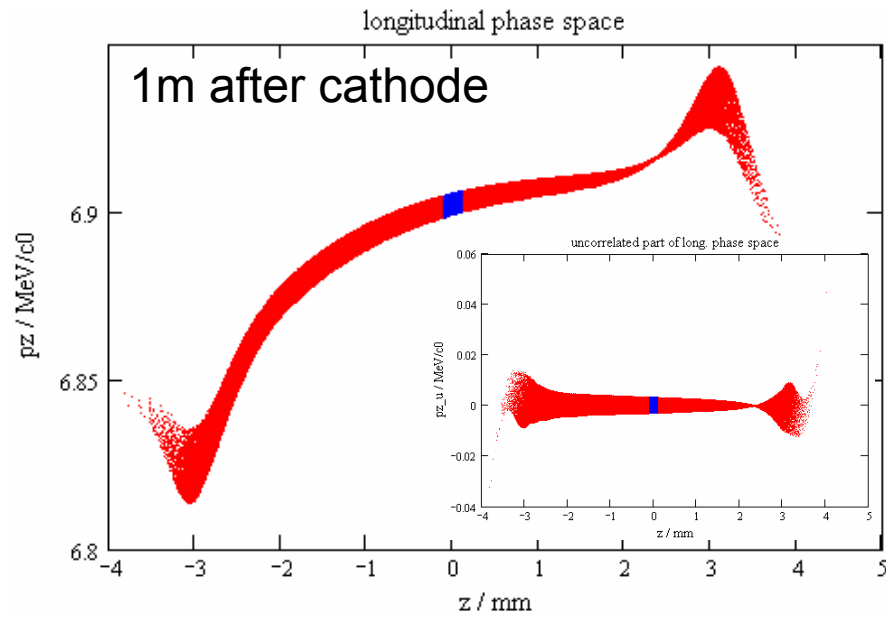

μ -bunch “instability”

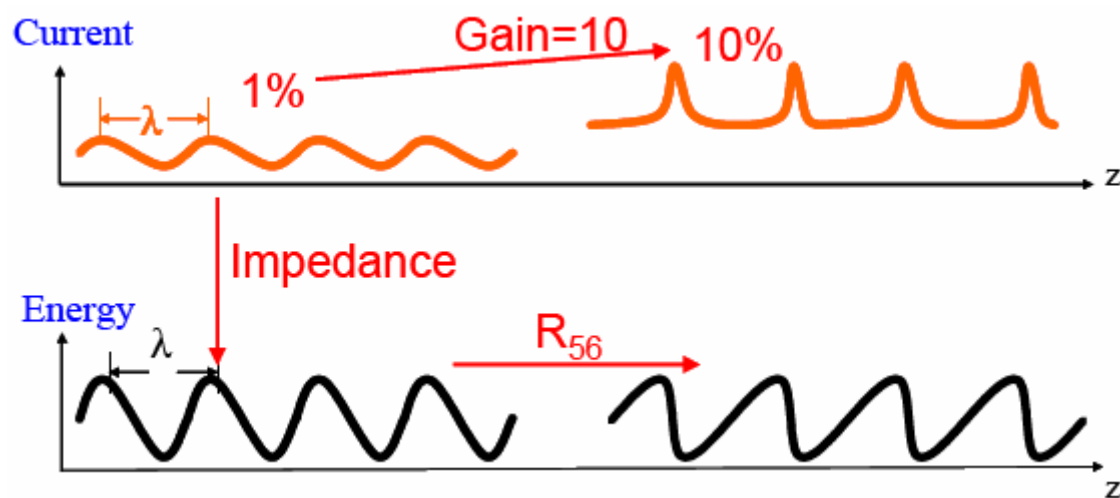

picture from
 Z. Huang, J.Wu: Microbunching instability due to bunch compression
http://icfa-usa.jlab.org/archive/newsletter/icfa_bd_nl_38.pdf

impedances (steady state):

$$Z'_{sc}(k, \sigma_r, R_{pipe}, \gamma) \approx \frac{iZ_0 k}{2\pi\gamma^2} \ln\left(\frac{\gamma}{k\sigma_r}\right) \quad (\text{free space, } k\sigma_r/\gamma \ll 1) \quad \text{“SC-instability”}$$

$$Z'_{CSR}(k, R_{curv}) \approx Z_0 \frac{\Gamma(2/3)}{2\pi} \sqrt[3]{\frac{k}{3iR_{curv}^2}} \quad \text{“CSR-instability”}$$

gain curves of μ -bunch “instability”

contributions of the sub-sections of the linac
for an uncorrelated energy spread of 10 keV

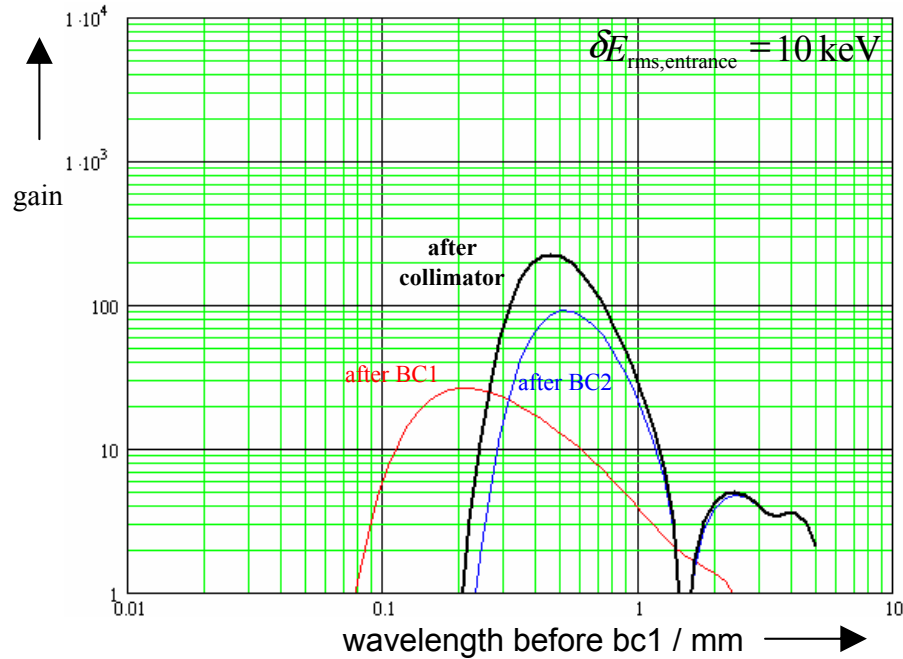

overall gain for different uncorrelated
energy spreads

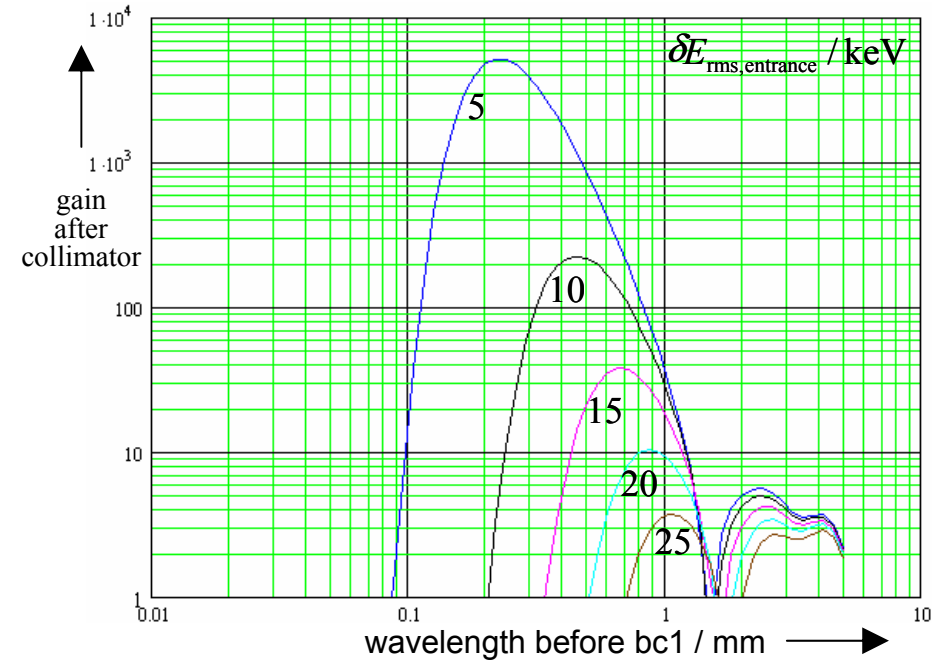

‘laser heater’ System (LCLS layout)

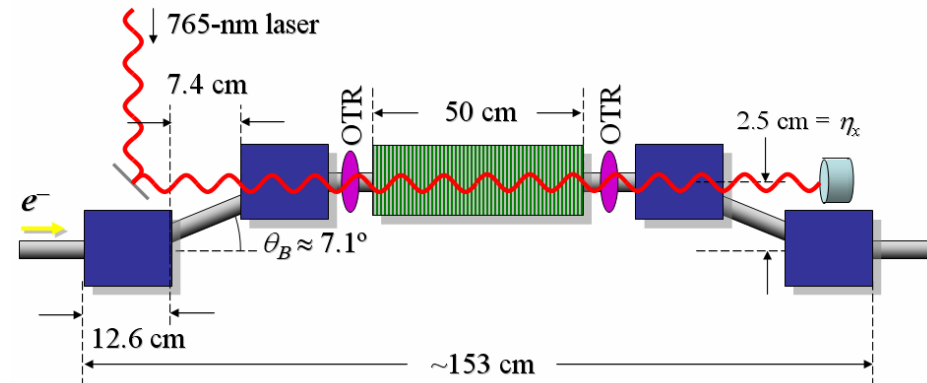

μ -bunch “instability”, numerical aspects

1) μ -bunch-gain calculations are not subject of full s2e simulations

2) → separate investigations

CSR: integral equation method (limited applicability)

projected method: modulated beam, 1- and 2-stage compression

SC: impedance + r56

3) s2e simulations:

avoid artificial instability

$N_{s2e} \ll$ number of electrons → use smoothing techniques

1d methods: adaptive filtering techniques

ASTRA: resolution of longitudinal mesh for calculation of space charge field

CSRtrack sub-bunch-method: use of ‘generating’ sub-bunches

European XFEL, segmentation

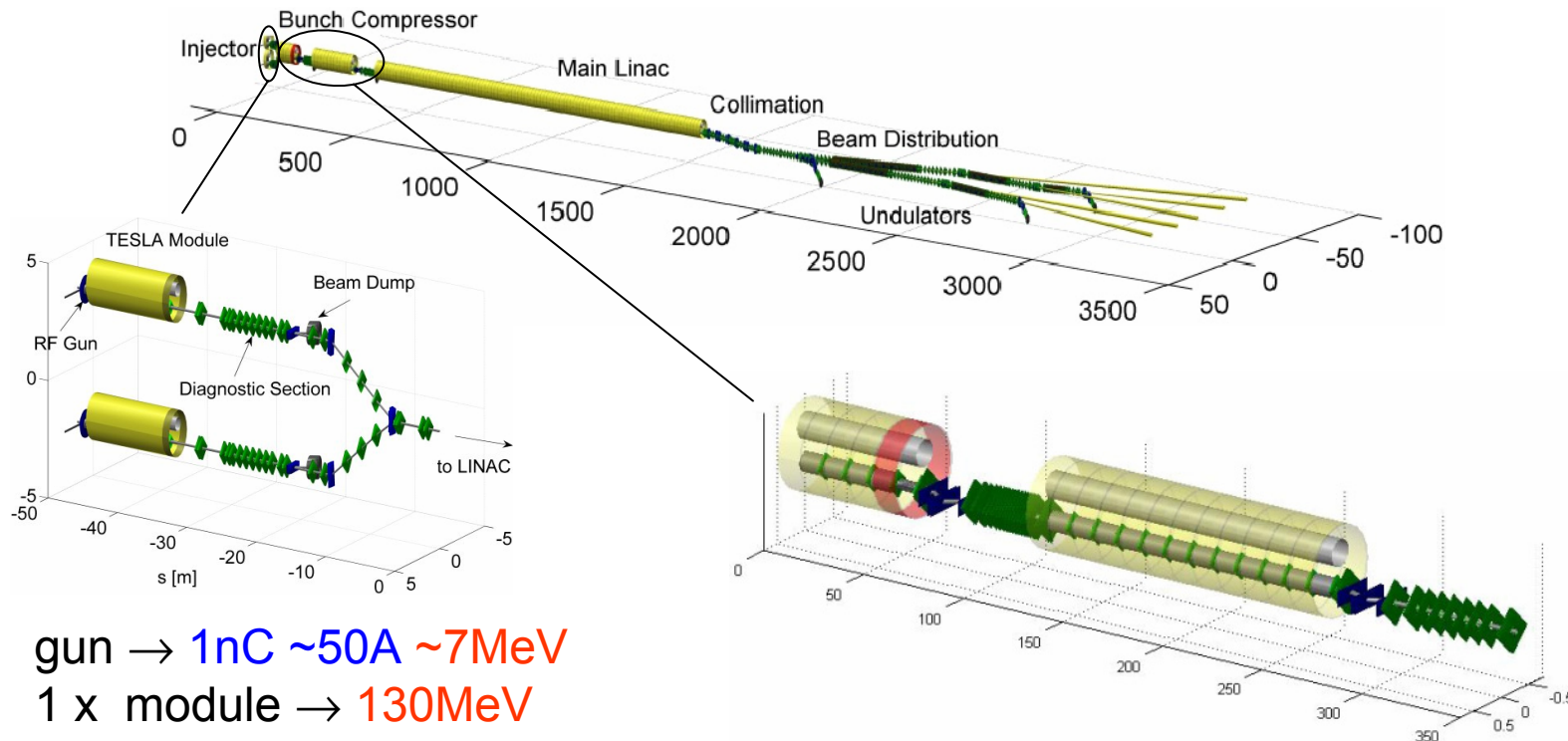

gun \rightarrow 1nC $\sim 50\text{A}$ $\sim 7\text{MeV}$

1 x module \rightarrow 130MeV

dogleg

4 x module + 2 x module-3rd \rightarrow 500MeV

bc1 \rightarrow $\sim 1\text{kA}$

12 x module \rightarrow 2GeV

bc2 \rightarrow $\sim 5\text{kA}$

main linac \rightarrow 17.5GeV

collimator

beam distribution ... undulators ...

European XFEL, segmentation

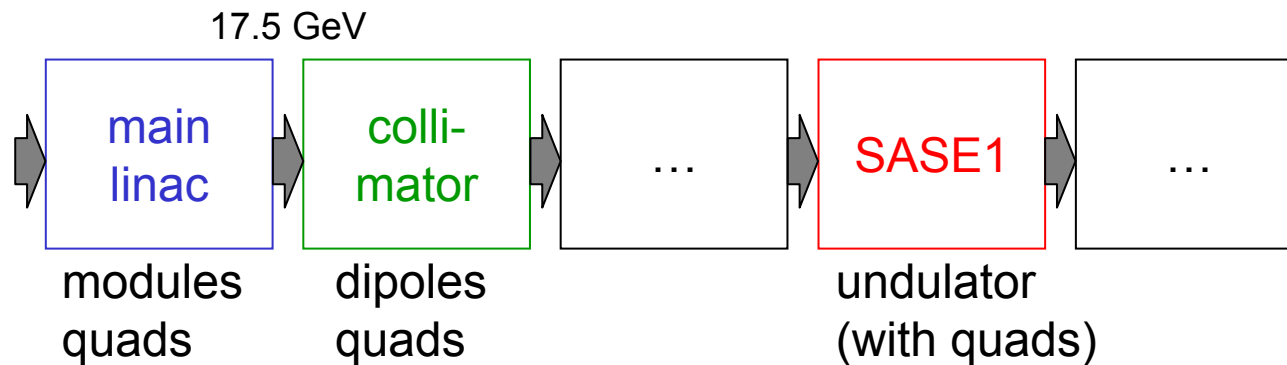
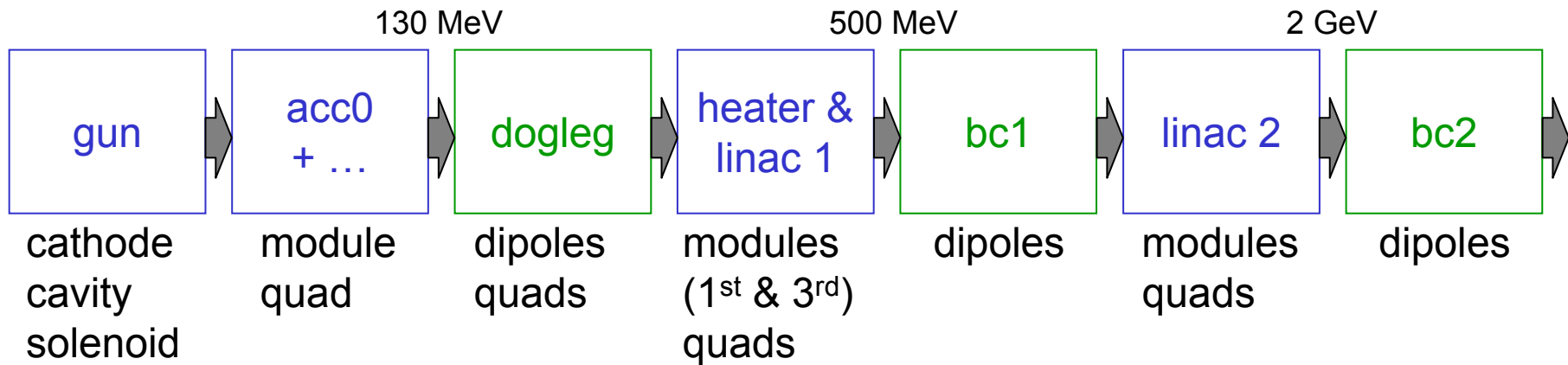
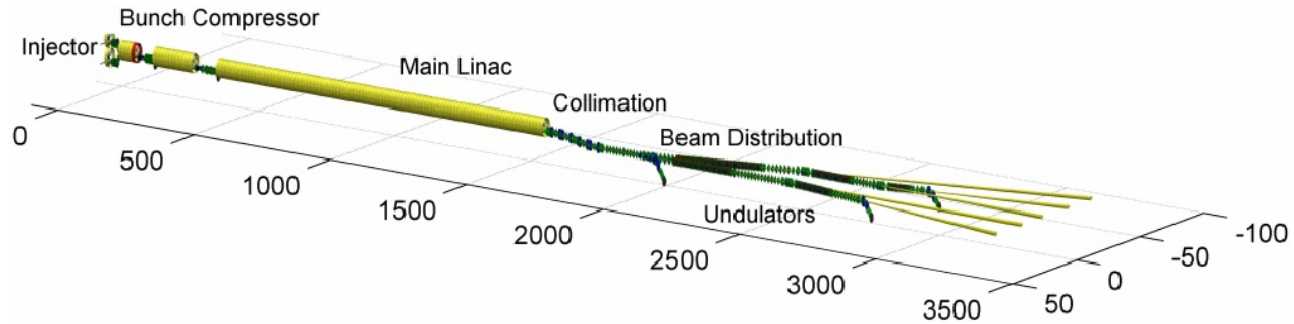

rf, dispersion

method 1 - fast

ASTRA

CSRtrack
'projected'

transport

rf-field
cavity wake & s.c. field

GENESIS

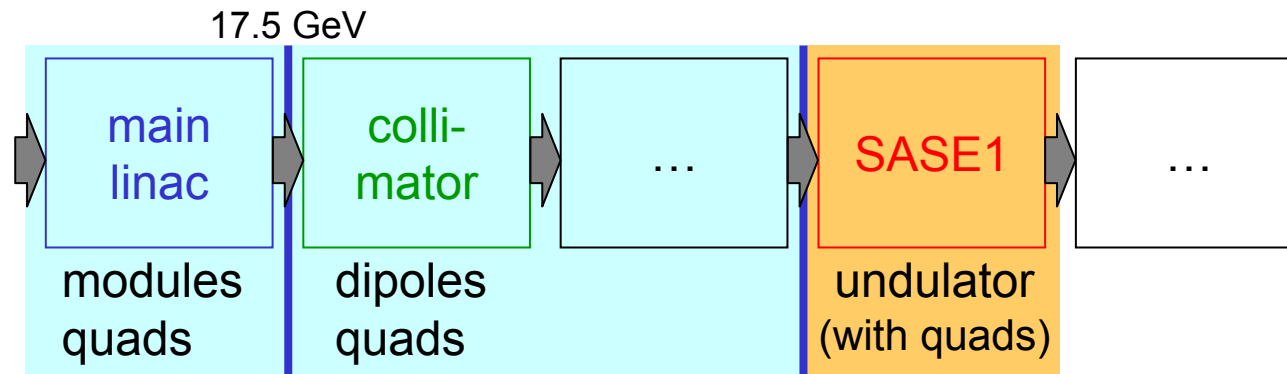
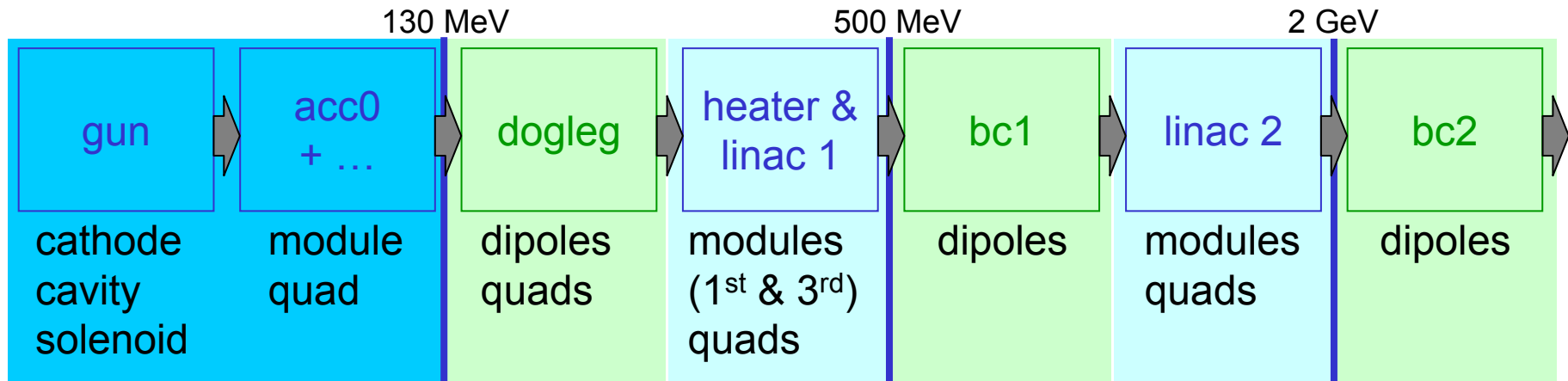

method 1

before BC1

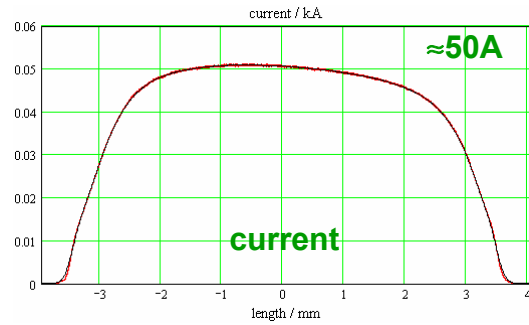

1.3GHz: 442.85 MV 1.42 deg
3.9GHz: 90.63 MV 143.35 deg

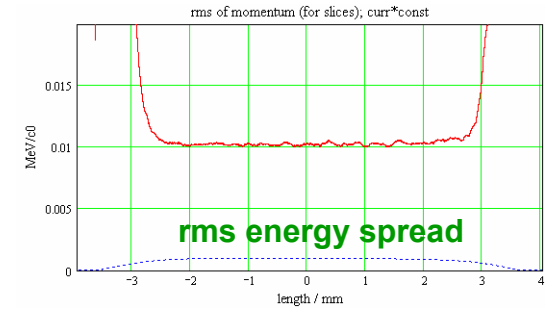
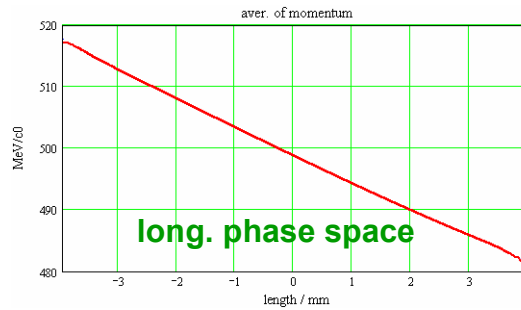

after BC1

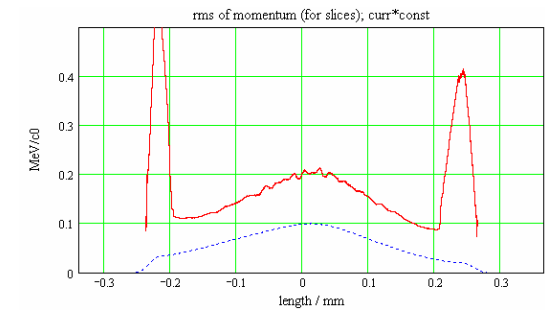
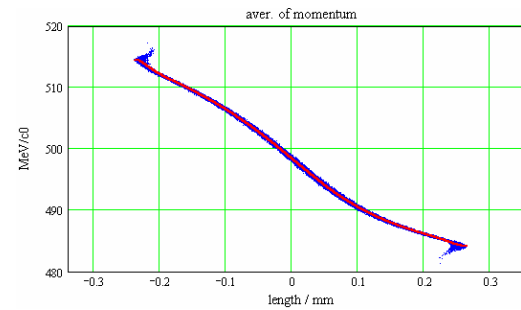
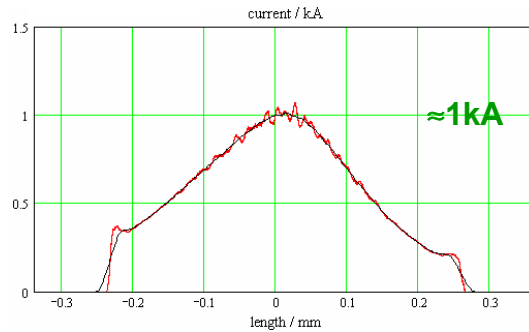

after BC2

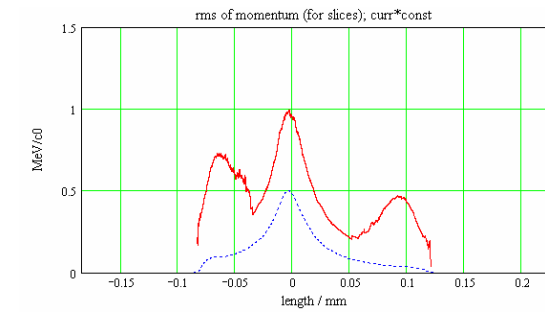
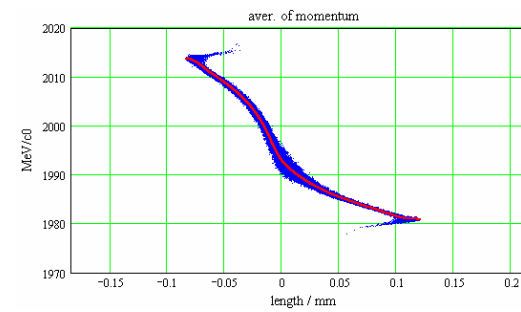
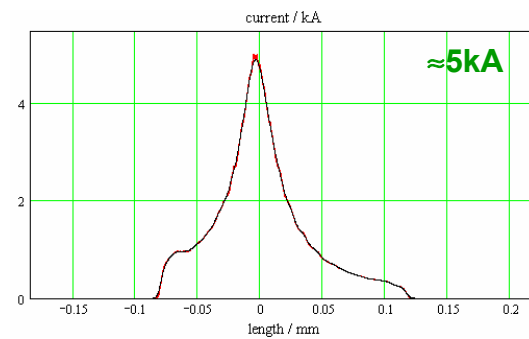

method 1

after BC2

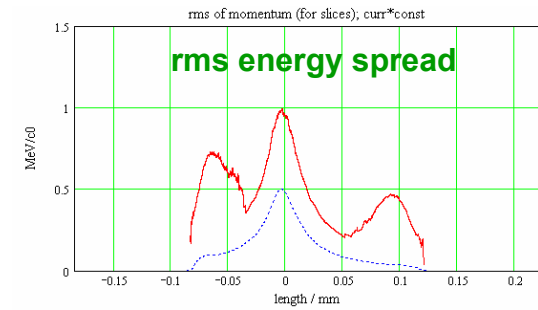
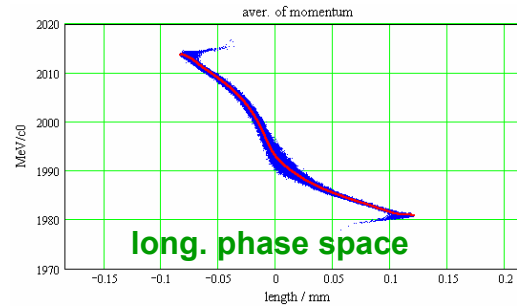
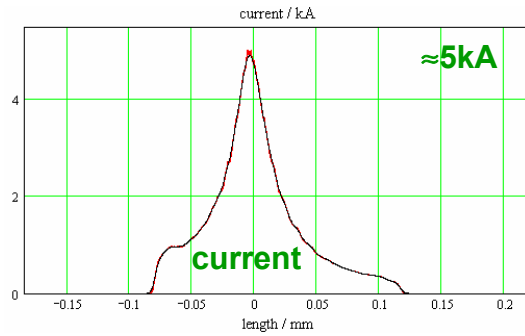

after collimator

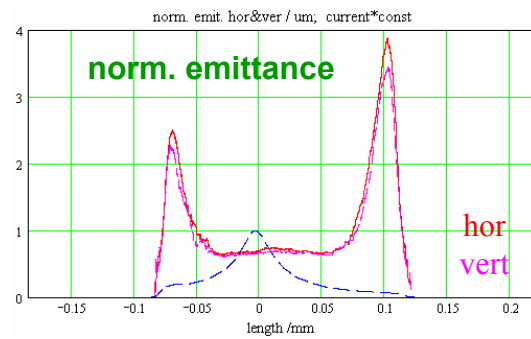
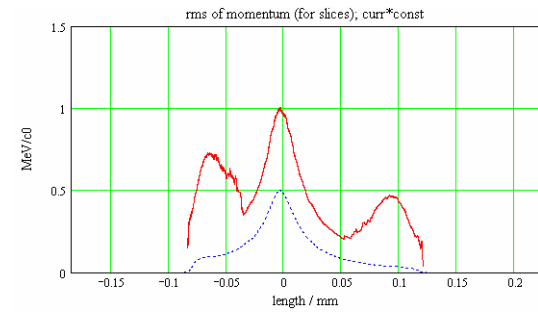
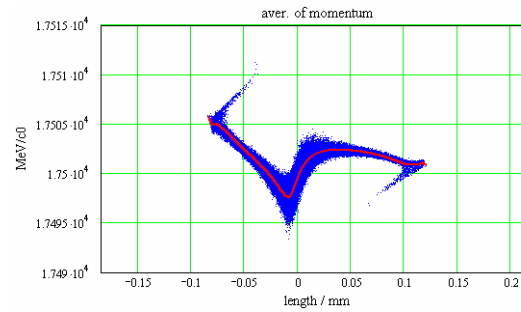
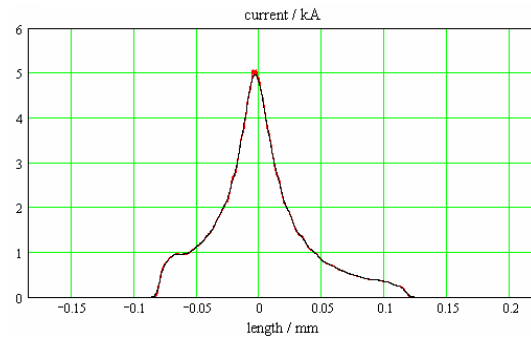

method 1 – GENESIS

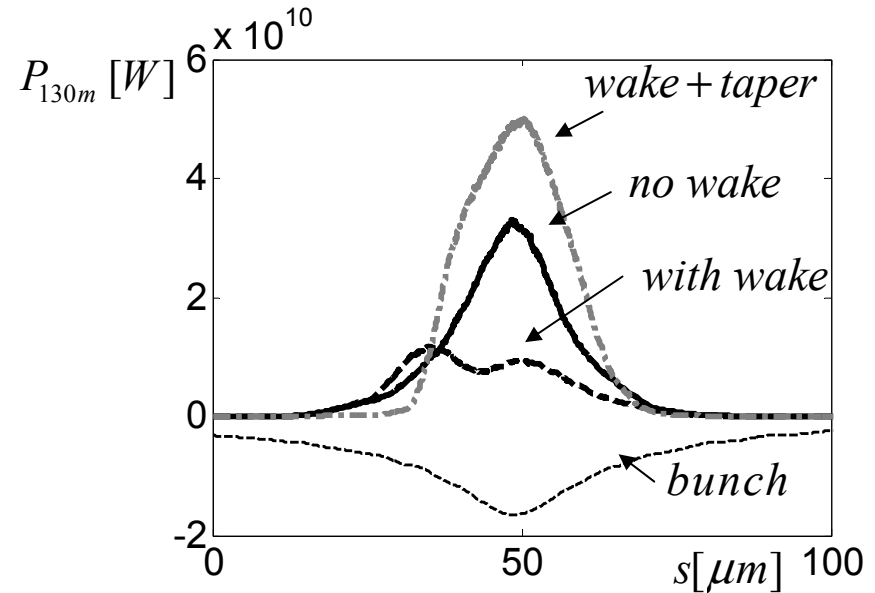
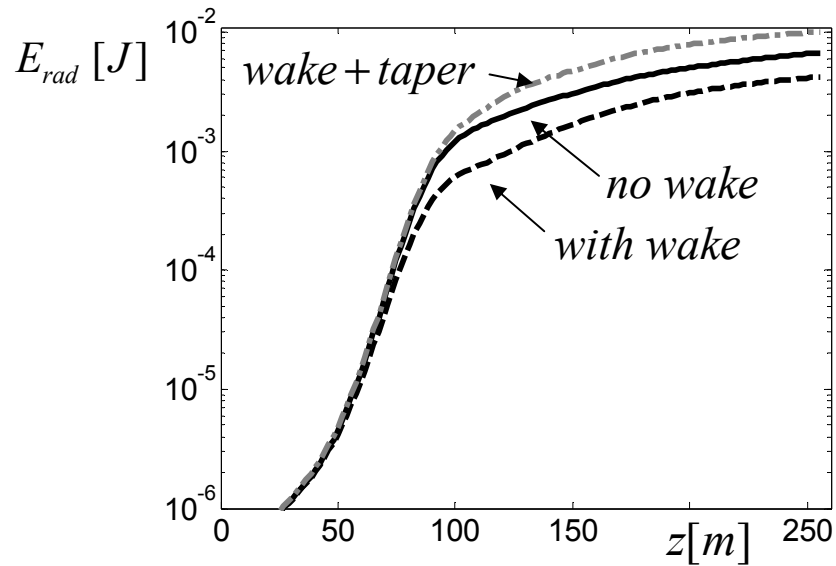

the radiation power at z=130m

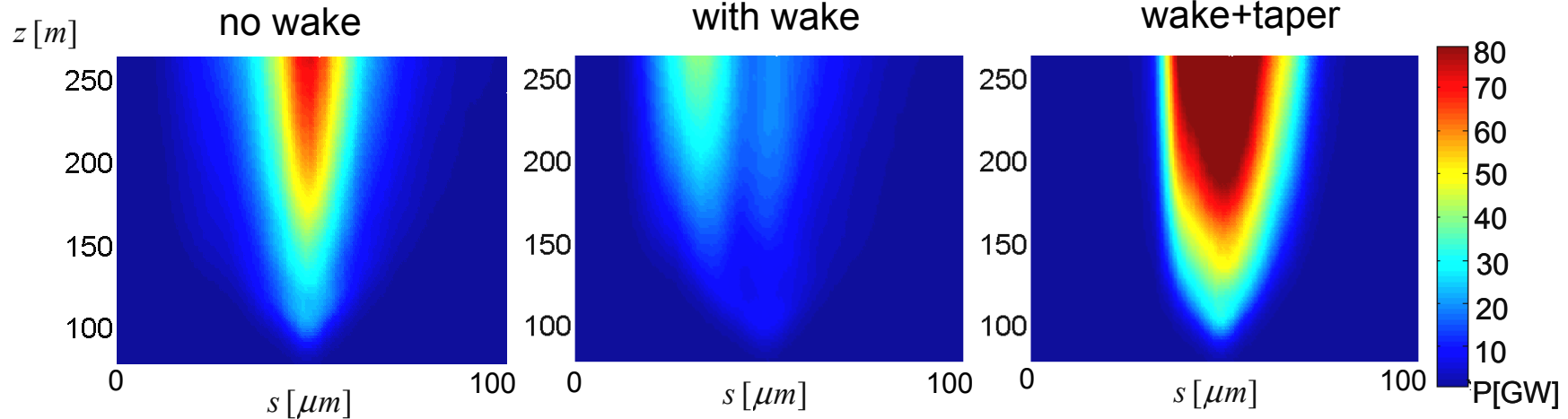

method 2 - reference

ASTRA

CSRtrack
sub-bunch

ELEGANT

rf-field
cavity wake & s.c. field

GENESIS

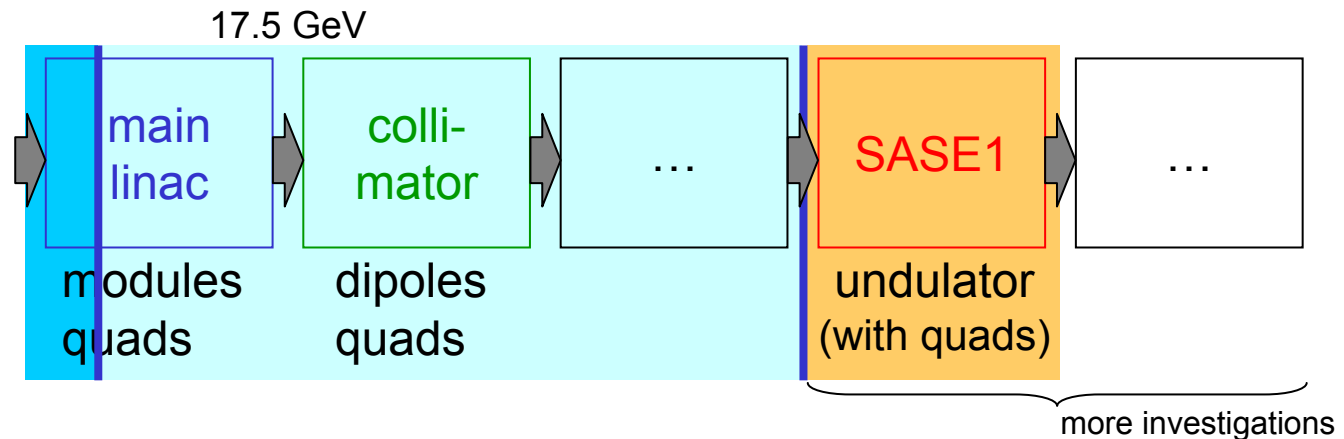
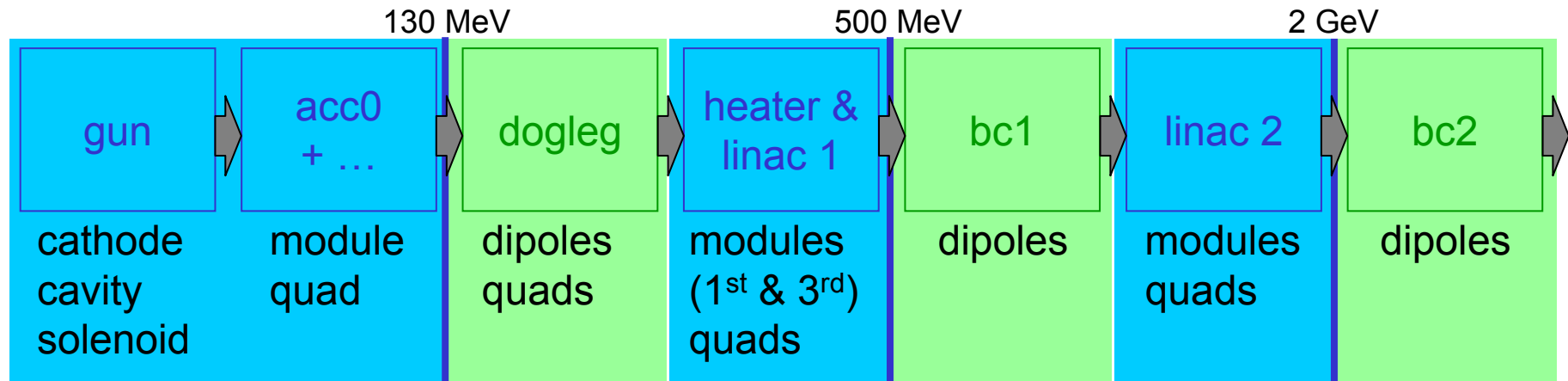

method 2

Address http://www.desy.de/xfel-beam/s2e/xfel_v4.html

European XFEL Start-to-End Simulations 2006

Schematic Layout of the XFEL

- Input field maps for ASTRA: aperture, solenoids, rf gun, 9-cell structure, half-module
- Input files for Poisson and Superfish: solenoids, rf gun, 9-cell structure

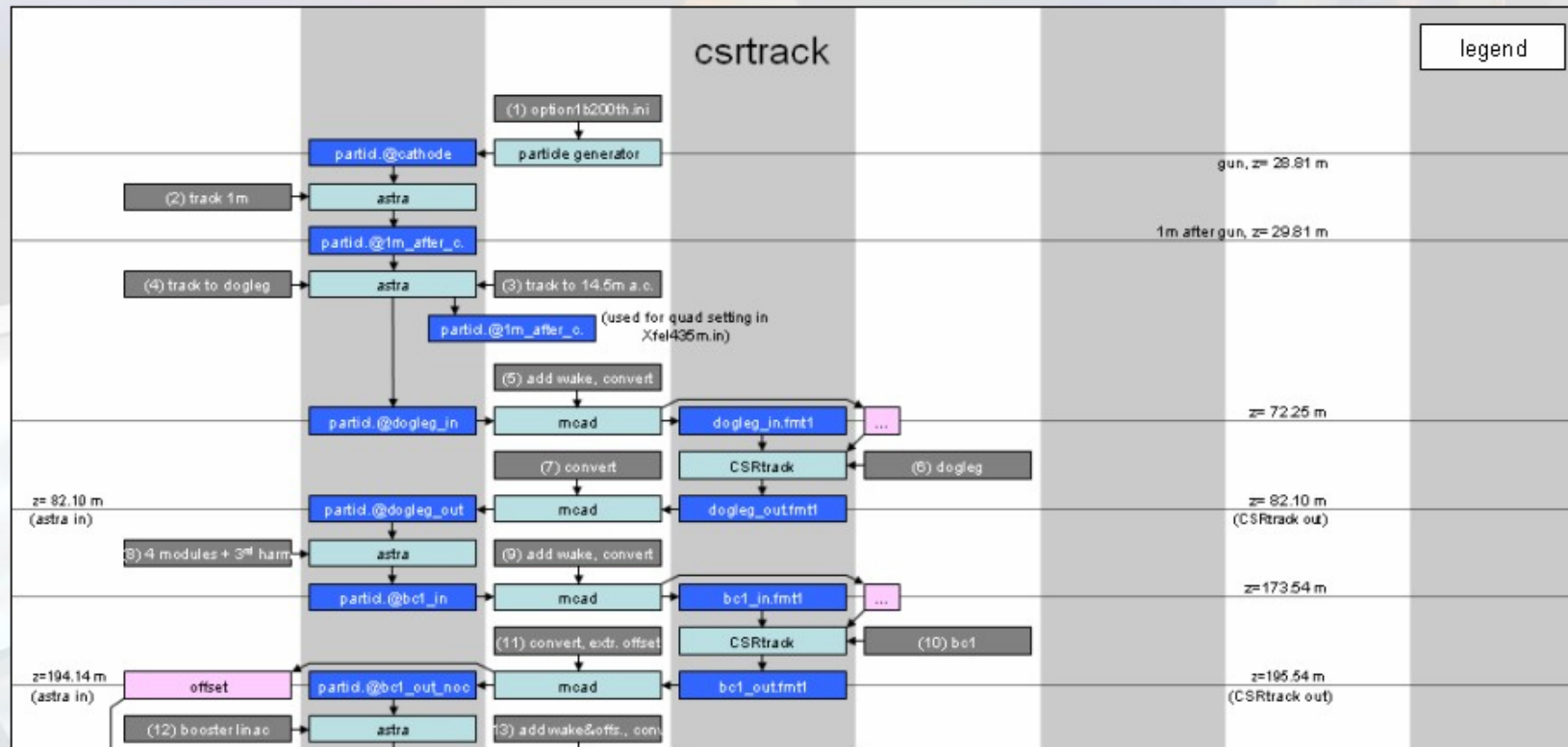

method 1

method 2

current & slice emittance

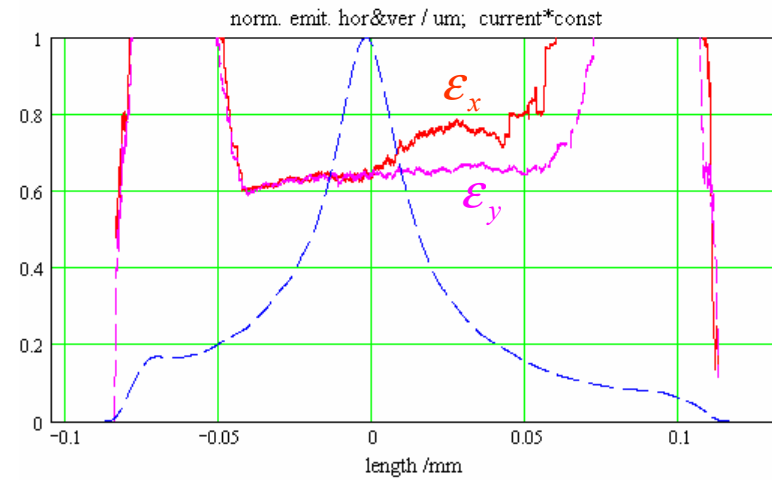
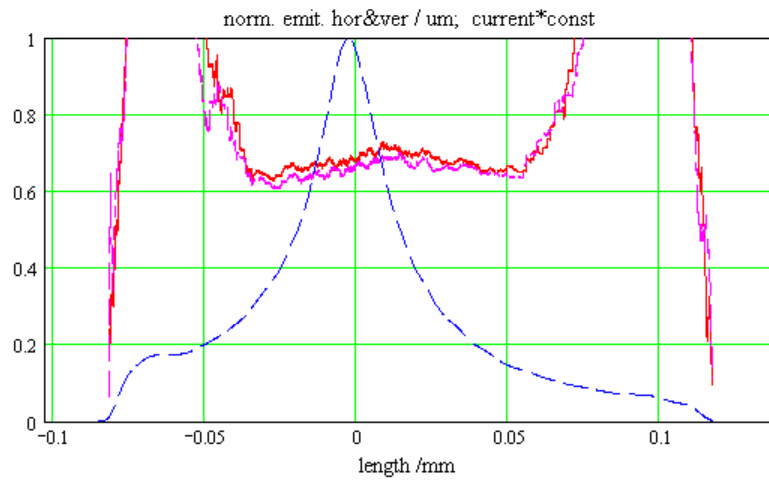
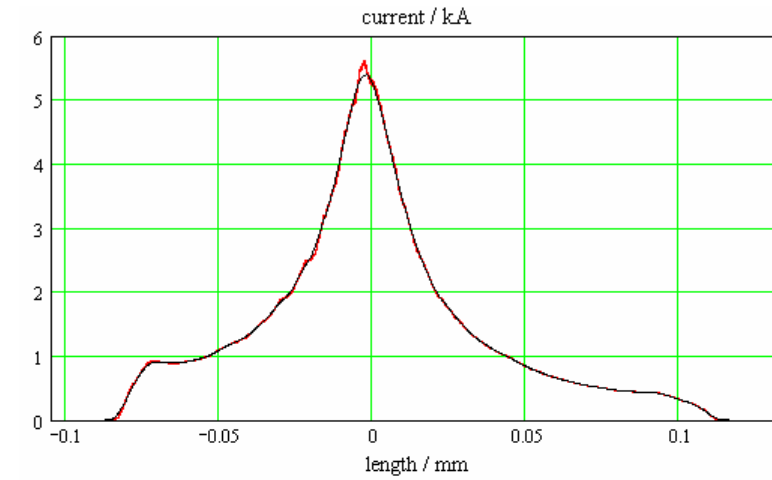
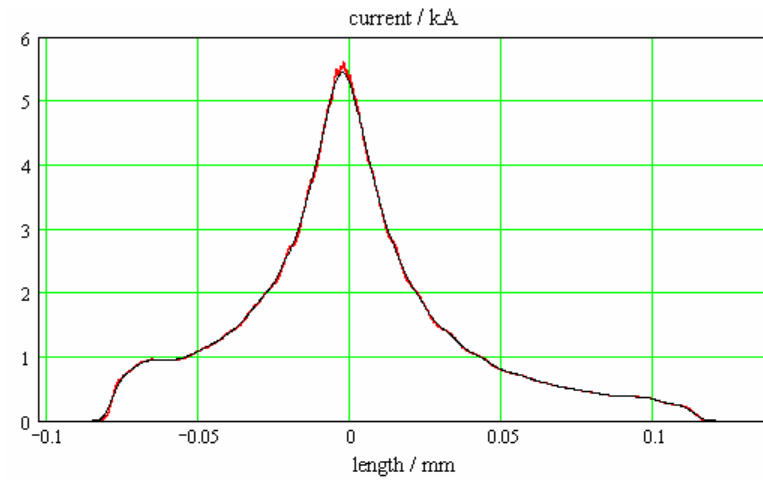

method 1

method 2

long. phase space

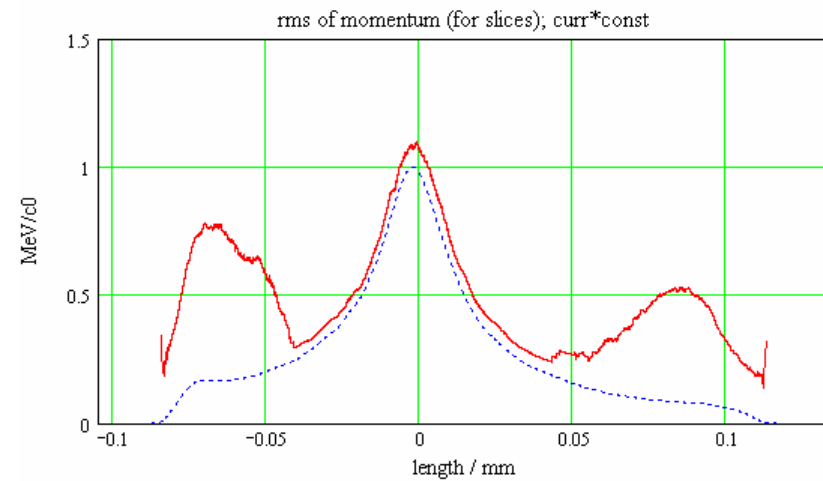
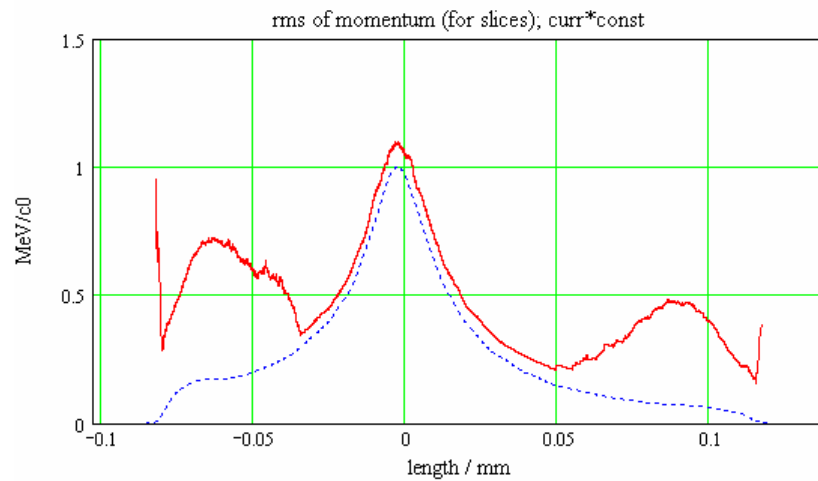
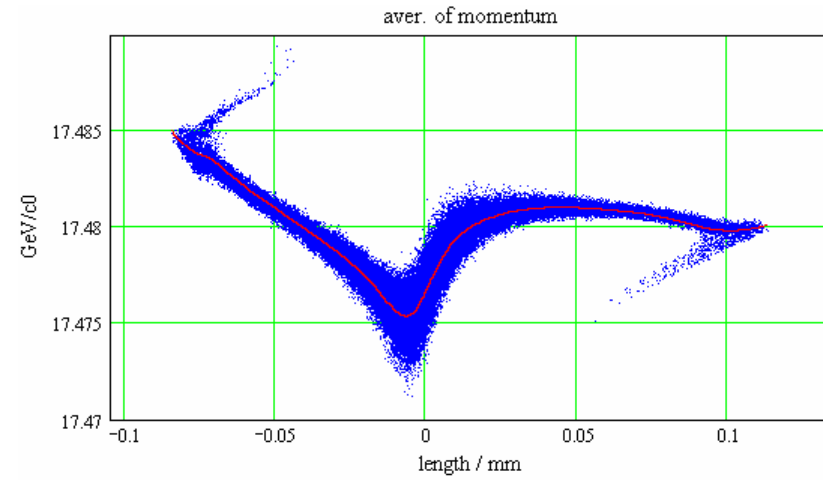
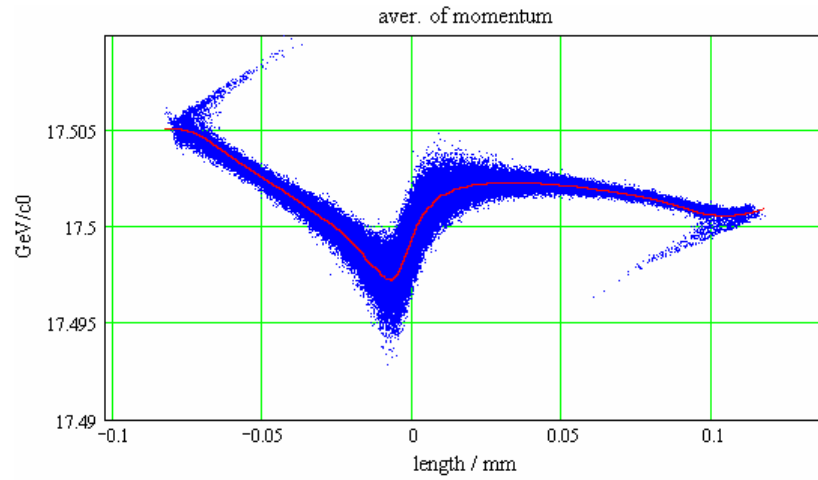

method 1

method 2

slice miss-match parameter with respect to the slice with the peak current
(self-miss-match)

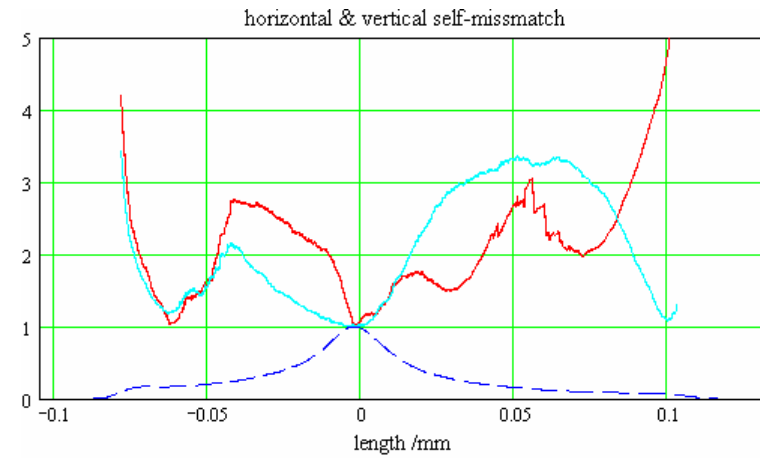
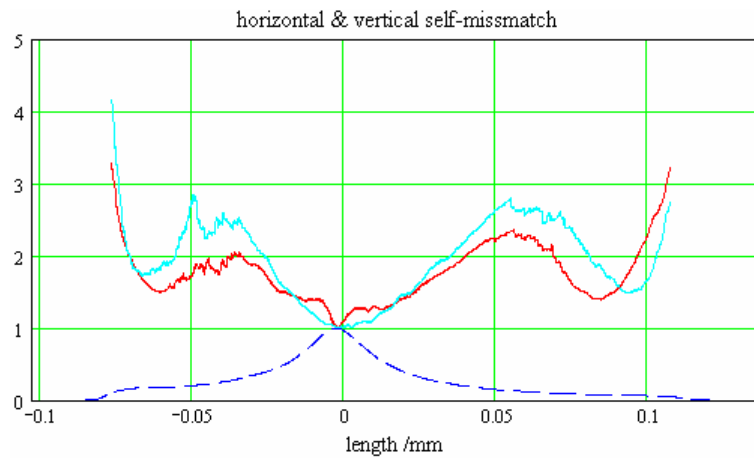

GENESIS: method 1 vs. method 2

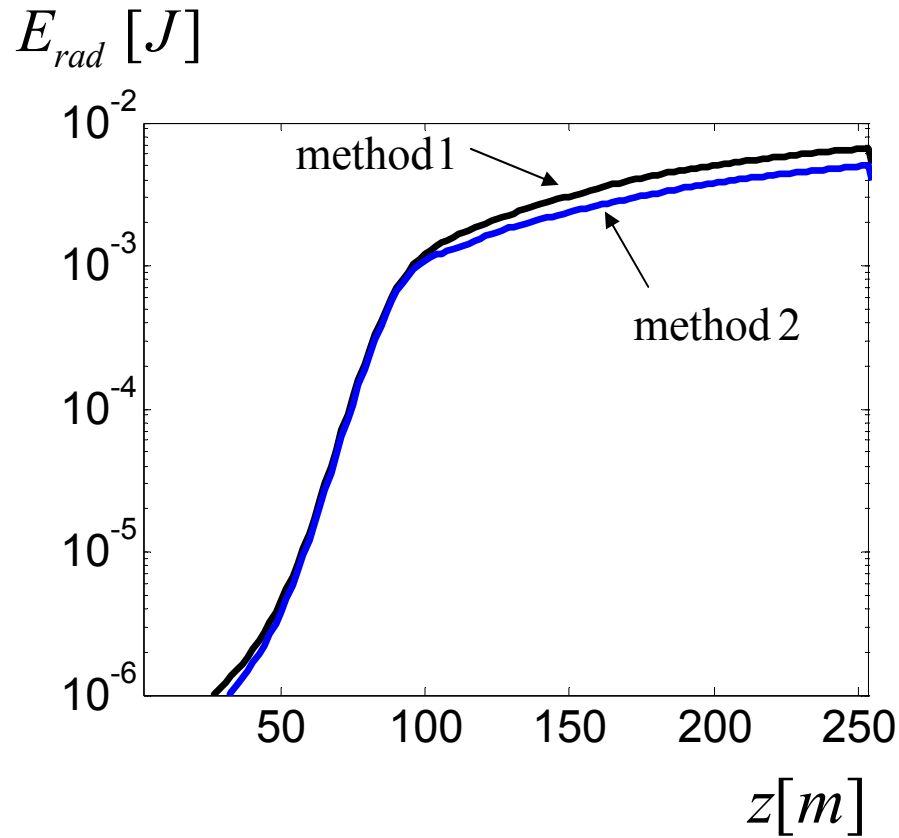

the radiation energy along the undulator

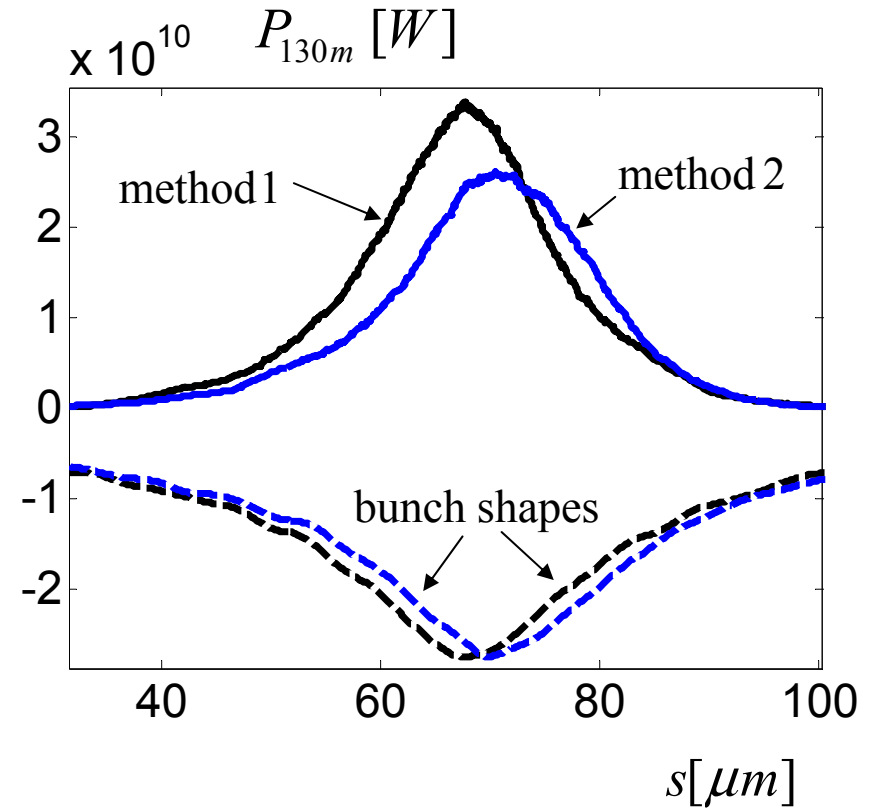

the radiation power along the bunch at $z=130m$

method 3 – accurate&efficient (to be done)

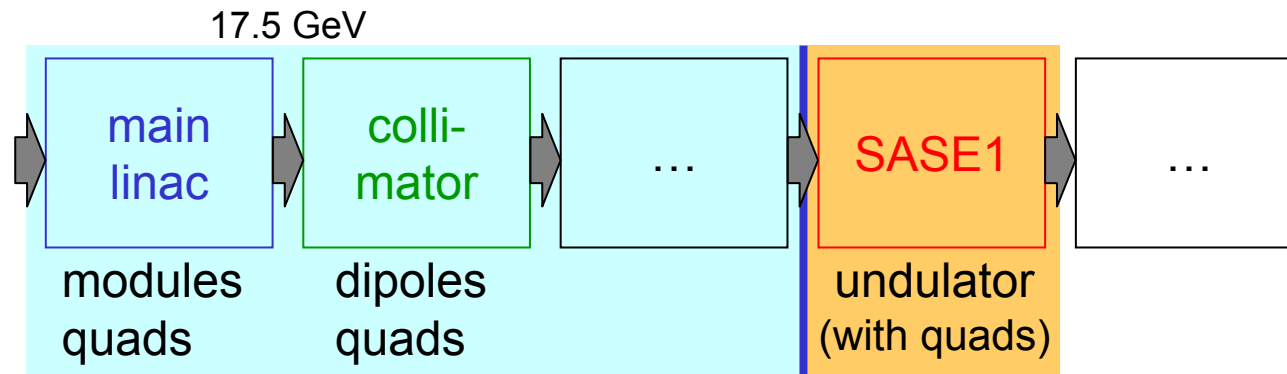
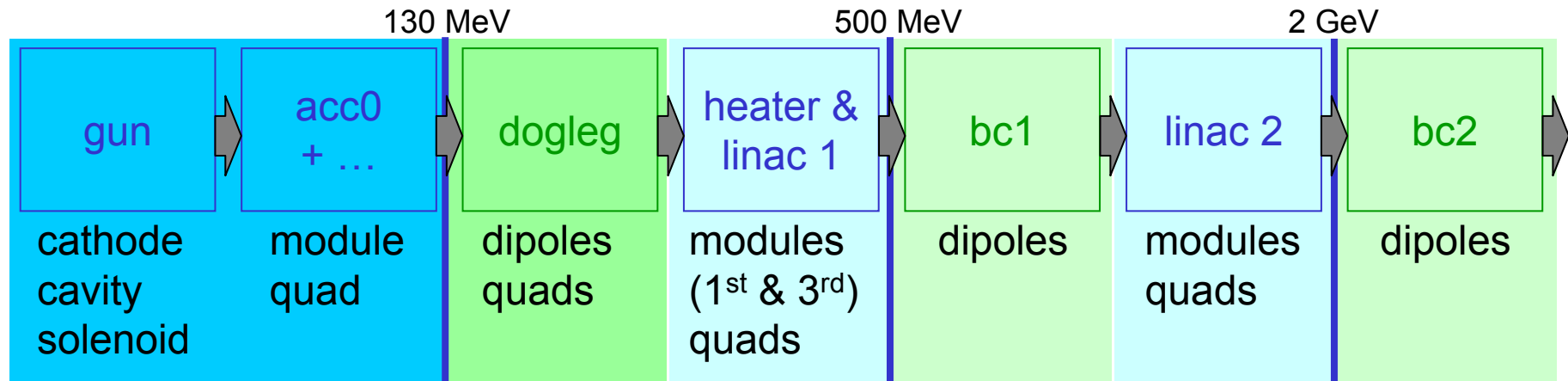

ASTRA (method 2) vs. ELEGANT (method 3)

linac before bc1

