

FLASH measurements: 8th of March 2012

- 1 Older Measurements
- 2 Measurements (setup, overview)
- 3 Optics
- 4 Calibration
- 5 Measurements (1-9)
- 6 Compression
- 7 Reconstruction (tt)
- 8 Initial Distribution
- 9 RF-Tweak Simulation
- 10 Wakes from Database
- 11 LOLA Mystery
- 12 Summary



1 Older Measurements

1 Measurements

FLASH Logbook Thursday 16. June 2011 Afternoon			
shift summary			
Tech. coord. * Goerler, Max	Run Coordinator(s) * Kammering, Raimund	Operators * Jahn, Hans-Joachim * Heuck, Kim * Rothenburg, Jens * Seebauer, Oliver * Behrens, Christopher	Other Persons * Edwards, Schneidmüller, Wesch
Photon coordinator(s) *	Photon Operators *	LLRF coordinator *	Users *
Goal	* Compression studies and SASE with 3.9 module		
Achievements	* set up on crest phases by C Schmidt using his time of flight tool. Worked well. * Turned off BC3 and changed Acc4/5 to on crest for this condition * Used LOLA to make compression measurements for Acc1/Ac39 phase change measurements of 1:1 and 1:3 * Changed phases from no to full compression To first order looked like matched prediction quite well. Needs analysis		

→ s2E seminar, June, 20, 2011:

Compression Studies
June 16, 18, 2011
Preliminary report

C Behrens, H Edwards,
E Schneidmüller, S Wesch,
C Schmidt



reconstruction of virtual initial distribution
→ TE-method and TT-method

problem with T&E calibration

spike

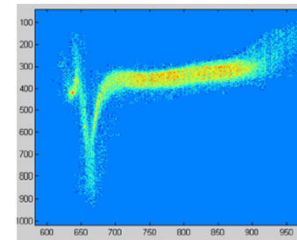

to some extent successful:
low & high compression

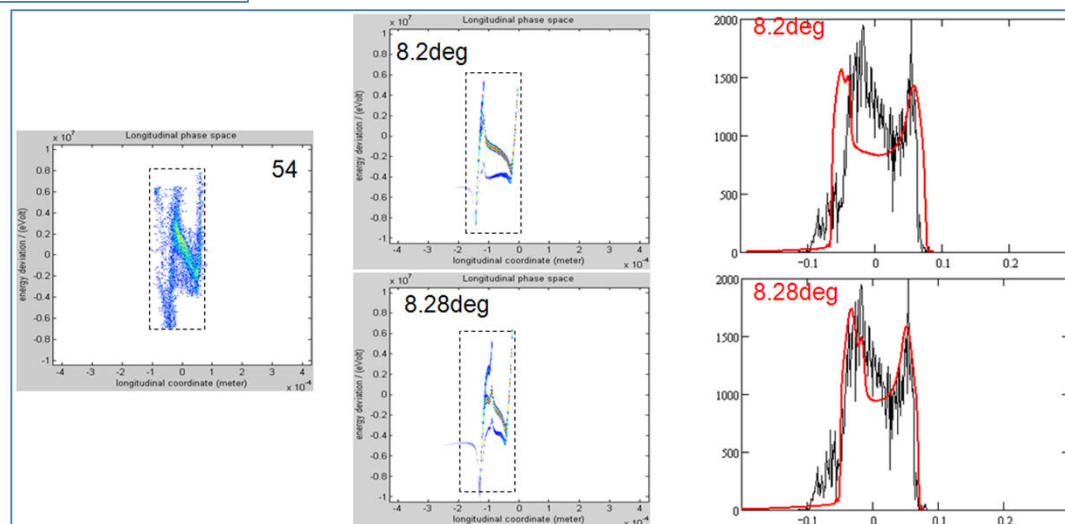

1 Older Measurements

middle compression is not understood:

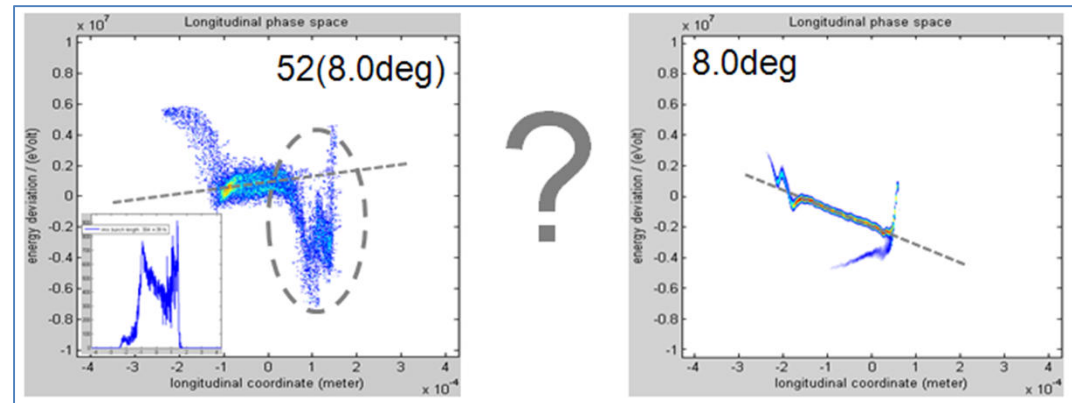

later: simulated LOLA measurements

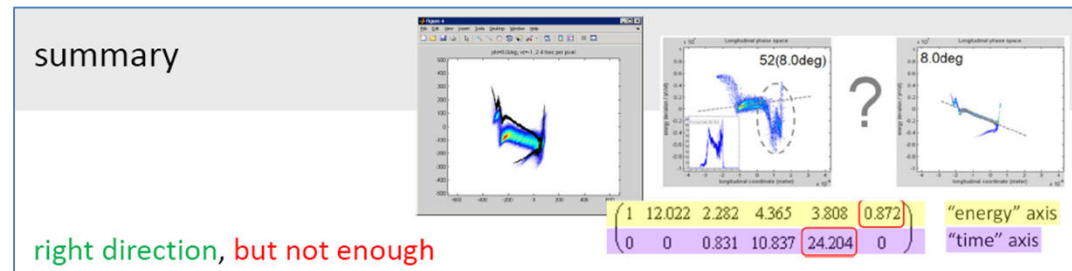

1 Older Measurements

LOLA picture not completely understood:

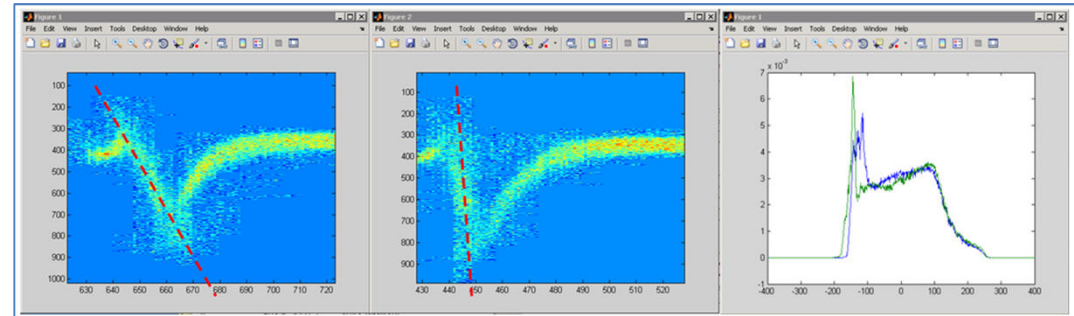

virtual initial distribution different from ASTRA
qualitative differences for ASTRA distribution

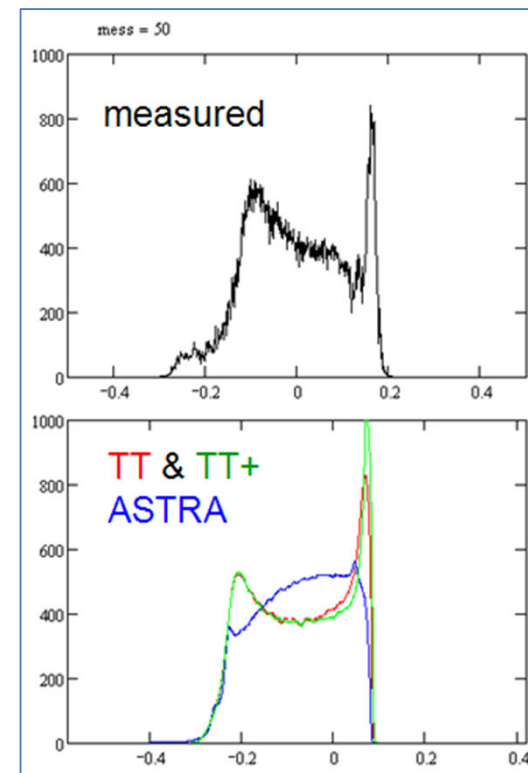

2 Measurements

March 8 and 9

FLASH Logbook **Thursday 08. March 2012 Afternoon** ← →

 **shift summary**

Tech. coord. Hopf, Peter	Run Coordinator(s) Kammering, Raimund	Operators Seebach, Michael Prien, Thomas Matzen, Oliver Hannemann, Juergen Petrosyan, Gevorg Ackermann, Sven	Other Persons H. Edwards, M. Dohlus, M. Yan, A. Langner, C. Schmidt, M. Vogt
Photon coordinator(s)	Photon Operators	LLRF expert	SASE expert

Goal * Compression studies 2012 with Acc3.9 module

Achievements * During first half of shift set up on crest phases and turned off BC3. On crest phase of Acc45 with BC3 on was not measured. Second half of shift Lola measurements from on crest to Acc1 phase 7.5, Acc39 phase -7.5. Final compression about 8 to 10. However at the end the transmission was 80% and the Lola plots looked like they could have been cut at the low energy tail. In general the compression appeared very linear compared to measurements of 06/2011. tomorrow we should try to restore the compressed conditions and check transmission before going to other operating point.



2 Measurements - Setup

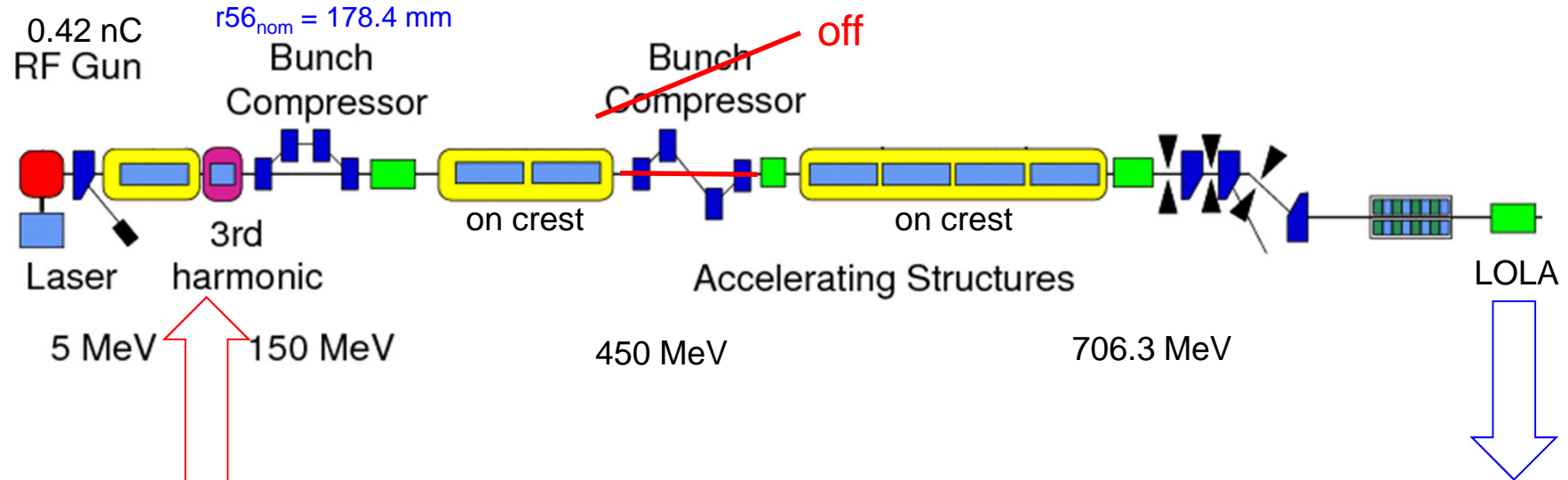

	GUN	ACC1	ACC39	ACC2/3	ACC4/5	ACC6/7
SP old	+ 3.930	+ 163.3	+ 18.0	+ 300.0	+ 249.0	+ 0.0
RB	3.930 3.92 MW	161.7 MV 163.3 MV	18.40 18.0 MV	330.00 296.2 MV	231.30 249.4 MV	0.00 0.1 MV
Phase old	+ 0.00	+ 0.00	+ 0.00	+ 0.00	- 58.00	+ 0.00
RB	-2.20 -142.0 deg	-4.2 deg 7.26 deg	-26.10 deg -0.1 deg	20.02 deg 0.9 deg	-1.80 deg -36.3 deg	0.00 deg 105.4 deg
on-crest	0.0 deg	0.0 deg	0.0 deg	0.0 deg	0.0 deg	0.0 deg
	17:46.14 8. Mar. 2	16:34.55 8. Mar.	16:39.47 8. Mar.	17:11.37 8. Mar.	26:14.42 27. Feb.	209:33.51 22. Feb.

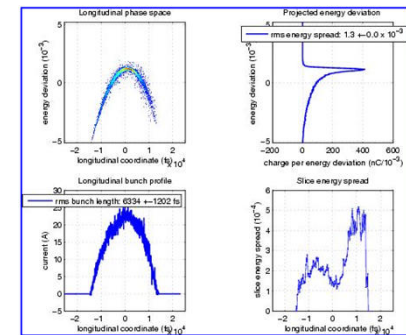

carefull phasing (BAM) before measurements



2 Measurements - Overview

shift 1

rf settings (phases/deg, amplitudes/MV)

time	index	P1	P2	P3	P4	A1	A2	A3	A4	index-2
8. March										
192745	time calibration	----- set LOLA amplitude -----								
194326	time calibration									
195414	energy calibration									
203551	time calibration									
204047	energy calibration									
204929	measurement 0+	0	0	0	-58	163.3	18	300.0	249.0	1
210357	measurement 1+	0	0	0	-58	163.3	18	300.0	249.0	3
211751	measurement 1-	0	0	0	-58	163.3	18	300.0	249.0	4
212614	time calibration									
212906	measurement 2-	1	-1	0	-58	163.3	18	300.0	249.0	6
213336	time calibration									
213542	measurement 2+	1	-1	0	-58	163.3	18	300.0	249.0	8
214039	time calibration									
214802	measurement 3+	2	-2	0	-58	163.4	18	300.0	249.0	10
215100	measurement 3-	2	-2	0	-58	163.4	18	300.0	249.0	12
215425	measurement 4-	3	-3	0	-58	163.5	18	300.0	249.0	14
215653	measurement 4+	3	-3	0	-58	163.5	18	300.0	249.0	16
220313	measurement 5+	4	-4	0	-58	163.7	18.1	300.0	249.0	18
220513	measurement 5-	4	-4	0	-58	163.7	18.1	300.0	249.0	20
220959	time calibration									
221246	measurement 6-	5	-5	0	-58	163.8	18.1	300.0	249.0	22
221729	measurement 6+	5	-5	0	-58	163.8	18.1	300.0	249.0	24
222030	measurement 7+	6	-6	0	-58	164.2	18.1	300.0	249.0	26
222219	measurement 7-	6	-6	0	-58	164.2	18.1	300.0	249.0	28
222447	measurement 8-	7	-7	0	-58	164.5	18.2	300.0	249.0	30
222624	measurement 8+	7	-7	0	-58	164.5	18.2	300.0	249.0	32
222904	measurement 9+	7.5	-7.5	0	-58	164.7	18.2	300.0	249.0	34
223058	measurement 9-	7.5	-7.5	0	-58	164.7	18.2	300.0	249.0	36
223346	time calibration									
223731	energy calibration									
9. March										
002052	time calibration									
002259	time calibration	----- new LOLA amplitude -----								
002519	measurement 10	8.86	2.8	0	0	165.7	18.8	320.0	222.0	38
002802	measurement 10	8.86	2.8	0	0	165.7	18.8	320.0	222.0	40
003645	time calibration	----- new LOLA amplitude -----								
003847	measurement 11	9.92	3.15	10	0	166.2	18.8	325.0	222.0	44
004731	measurement 11	9.92	3.15	10	0	166.2	18.8	325.0	222.0	46

phase of LOLA measurement



3 Measurements - Overview

shift 2 ...

time	index	P1	P2	P3	P4	A1	A2	A3	A4	index-2
9. March										
155002	time calibration	----- set LOLA amplitude -----								
160553	energy calibration									
160740	measurement 25	7.5	-7.5	0	-58	164.7	18.2	300.0	253.0	48
174906	time calibration									
175453	energy calibration									
175632	measurement 26	0	0	0	-57.9	163.3	18	300.0	253.0	50
180140	measurement 27	0	0	0	-57.9	163.3	18	300.0	253.0	52
181758	measurement 28	7.5	-7.5	0	-57.9	164.7	18.2	300.0	253.0	54
182336	time calibration									
182722	measurement 29	7.5	-7.5	0	-57.9	164.7	18.2	300.0	253.0	56
183037	measurement 30	7.5	-7.5	0	-57.9	164.7	18.2	300.0	253.0	57
183849	time calibration	----- new LOLA amplitude -----								
184046	measurement 31	7.5	-7.5	0	-57.9	164.7	18.2	300.0	253.0	59
185030	time calibration									
185224	measurement 32	7.5	-7.5	0	-57.9	164.7	18.2	300.0	253.0	61
190007	measurement 33	7.5	-7.5	0	-57.9	164.7	18.2	300.0	253.0	63
191934	time calibration									
192158	time calibration									
192443	measurement 34	10	1	0	-57.9	165.8	18	300.0	253.0	65
192743	measurement 35	10	1	0	-57.9	165.8	18	300.0	253.0	67
193515	measurement 36	12	7.2	0	-57.9	167.0	18.2	300.0	253.0	69
193642	measurement 37	12	7.2	0	-57.9	167.0	18.2	300.0	253.0	71
194451	measurement 38	7.5	-6.6	0	-57.9	164.7	18.1	300.0	253.0	73
194845	measurement 39	7.5	-6.6	0	-57.9	164.7	18.1	300.0	253.0	75
195058	measurement 40	5	-14	0	-57.9	163.8	18.6	300.0	253.0	77
195227	measurement 41	5	-14	0	-57.9	163.8	18.6	300.0	253.0	79
195552	measurement 42	2.5	-20.8	0	-57.9	163.5	19.3	300.0	253.0	81
195953	measurement 43	2.5	-20.8	0	-57.9	163.5	19.3	300.0	253.0	83
200208	measurement 44	0	-27.1	0	-57.9	163.3	20.2	300.0	253.0	85
200334	measurement 45	0	-27.1	0	-57.9	163.3	20.2	300.0	253.0	87
202259	measurement 46	0	-28.3	0	-57.9	163.3	20.5	300.0	253.0	89
202436	measurement 47	0	-28.3	0	-57.9	163.3	20.5	300.0	253.0	91
202750	measurement 48	12	5.6	0	-57.9	167.0	18.1	300.0	253.0	93
202923	measurement 49	12	5.6	0	-57.9	167.0	18.1	300.0	253.0	95
203501	measurement 50	12	5.1	0	-57.9	166.9	18.1	300.0	253.0	97
203638	measurement 51	12	5.1	0	-57.9	166.9	18.1	300.0	253.0	99
204833	time calibration									
205229	energy calibration									



2 Measurements - Overview

... shift 2

time	index	P1	P2	P3	P4	A1	A2	A3	A4	index-2
205622	measurement 52	7.5	-6.6	0	-57.9	164.7	18.1	300.0	253.0	101
205849	measurement 53	7.5	-6.6	0	-57.9	164.7	18.1	300.0	253.0	103
210244	time calibration									
210622	measurement 54	7.5	-6.6	0	-57.9	164.7	18.1	300.0	253.0	104
211911	time calibration									
212114	measurement 55	7.5	-6.6	0	-57.9	164.7	18.1	300.0	253.0	106
212252	measurement 56	7.5	-6.6	0	-57.9	164.7	18.1	300.0	253.0	108
213255	measurement 57	7.5	-6.6	0	-57.9	164.7	18.1	300.0	253.0	110
213442	measurement 58	7.5	-6.6	0	-57.9	164.7	18.1	300.0	253.0	112
214250	measurement 59	7.5	-6.6	0	-57.9	164.7	18.1	300.0	253.0	114
214457	measurement 60	7.5	-6.6	0	-57.9	164.7	18.1	300.0	253.0	116
220255	time calibration									
220515	measurement 61	7.5	-6.6	0	-57.9	164.7	18.1	300.0	253.0	118
220806	time calibration	----- ??? new LOLA amplitude -----								
221209	time calibration	----- ??? old LOLA amplitude -----								
221415	measurement 62	7.5	-6.6	0	-57.9	164.7	18.1	300.0	253.0	120
222513	measurement 63	10	1	0	-57.9	165.8	18	300.0	253.0	122
222928	measurement 64	10	1	0	-57.9	165.8	18	300.0	253.0	124
223241	measurement 65	12	7.2	0	-57.9	166.9	18.2	300.0	253.0	126
223412	measurement 66	12	7.2	0	-57.9	166.9	18.2	300.0	253.0	128
223639	measurement 67	0	-27.1	0	-57.9	163.3	20.2	300.0	253.0	130
223812	measurement 68	0	-27.1	0	-57.9	163.3	20.2	300.0	253.0	132
224140	measurement 69	2.5	-20.8	0	-57.9	163.5	19.3	300.0	253.0	134
224504	measurement 70	2.5	-20.8	0	-57.9	163.5	19.3	300.0	253.0	136
224702	measurement 71	5	-14	0	-57.9	163.8	18.6	300.0	253.0	138
224817	measurement 72	5	-14	0	-57.9	163.8	18.6	300.0	253.0	140



3 Optics

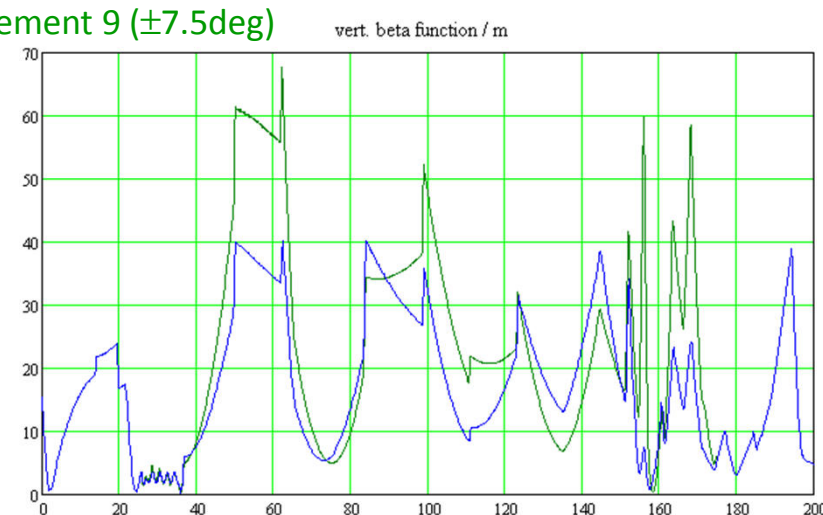
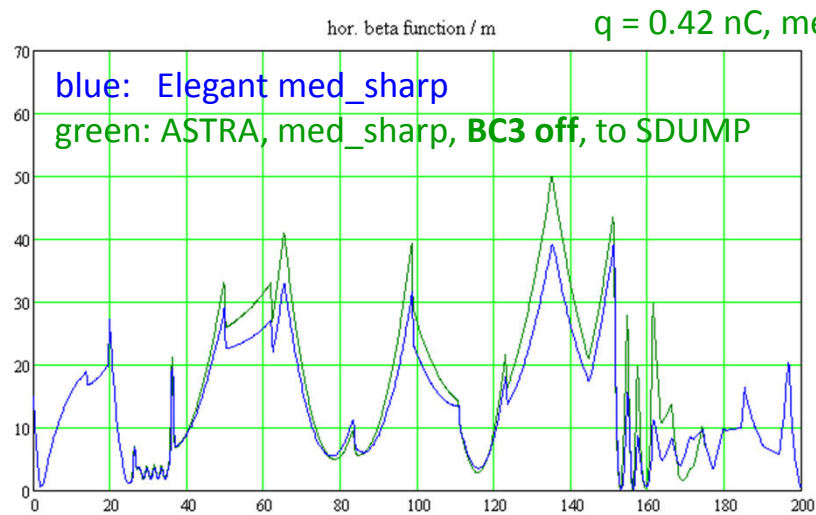
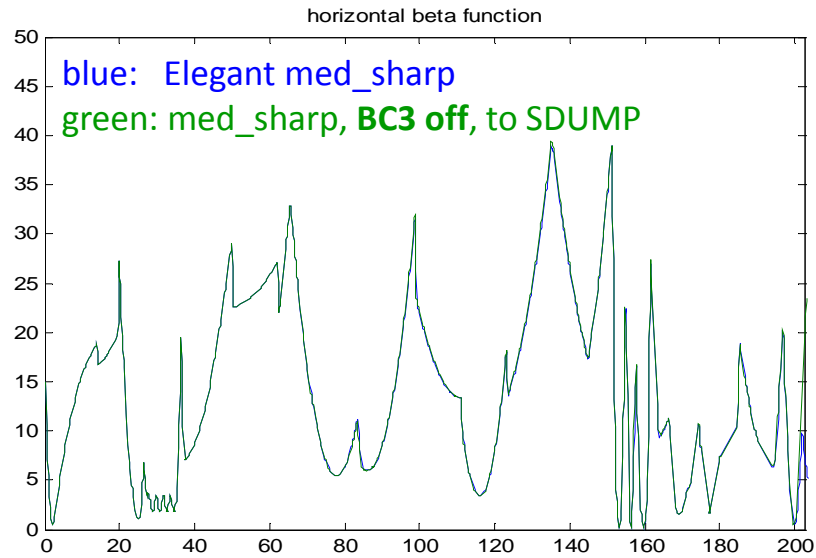

4 Calibration

shift 1: measurements with constant LOLA amplitude
calibration for measurement 1-9

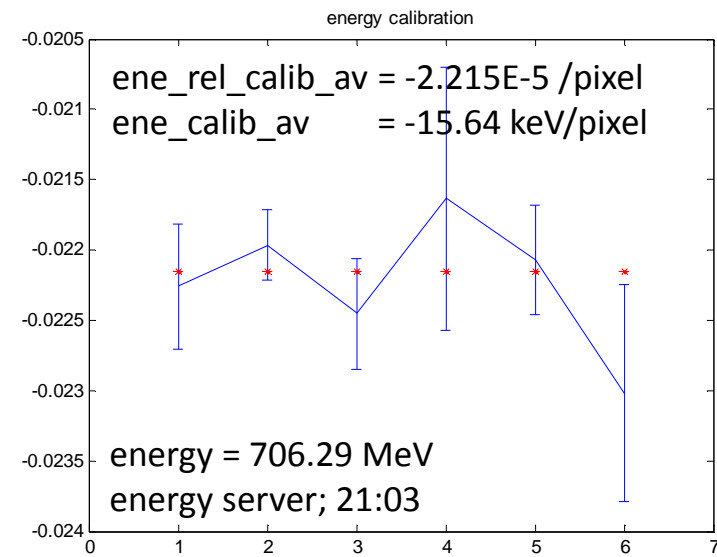
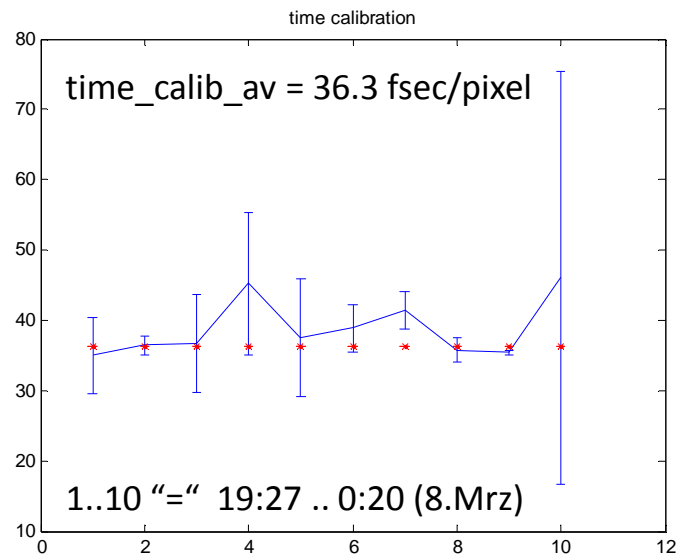

5 Measurements (1-9)

same LOLA amplitude for all measurements

procedure: each measurement with both zero crossings of LOLA

- +sign, 1 screen shot
- , 10 screen shots
- -sign, 1 screen shot
- , 10 screen shots

use 10-screen-shot measurements:

- flip time axis for -sign measurement
- calculate projection to “time” axis
- calculate mean “energy” vs. time
- center and average these distributions

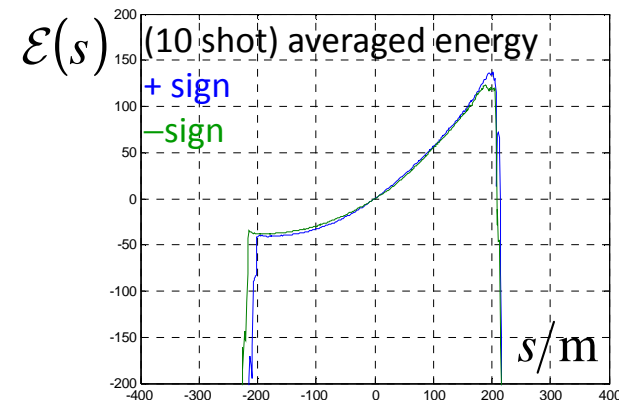
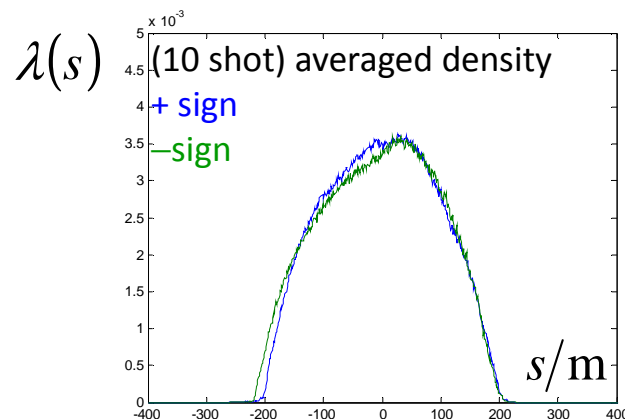

5 Measurements (1-9)

... procedure: calculate “charge”-coordinate
 idea: 1d distribution in longitudinal phase space

$$x^{\pm}(s) = \frac{1}{q} \int_{-\infty}^s \lambda^{\pm}(\tilde{s}) d\tilde{s} \quad \rightarrow s^{\pm}(x)$$

average densities of +sign and –sign measurement using the
 “charge” coordinate

$$s(x) = s^{+}(x) + s^{-}(x) \quad \rightarrow \lambda(s) = q \frac{d}{ds} x(s)$$

$$\mathcal{E}(x) = \mathcal{E}^{+}(x) + \mathcal{E}^{-}(x)$$

+ sign (10av) – sign (10av) ± av (2×10av)

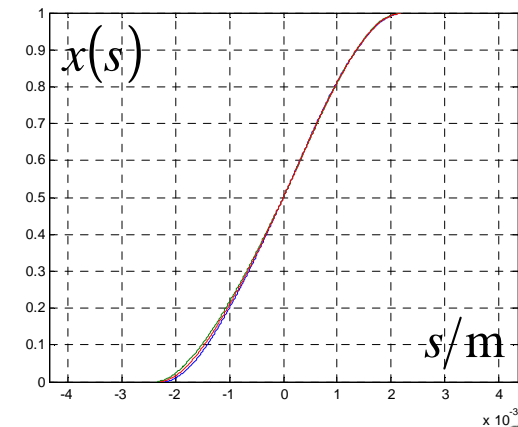
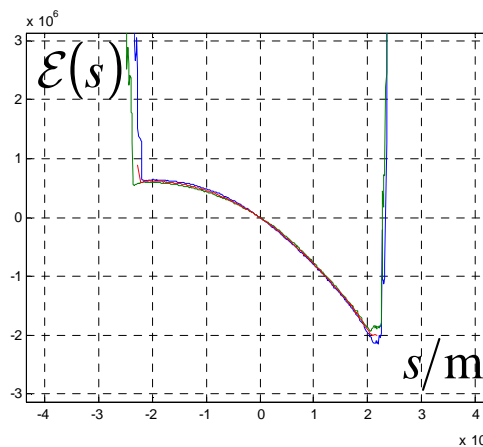
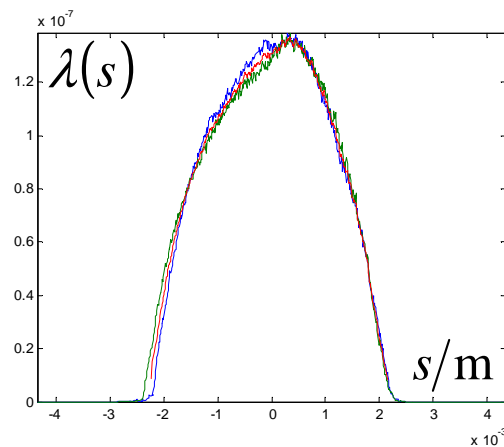

5 Measurements (1-9)

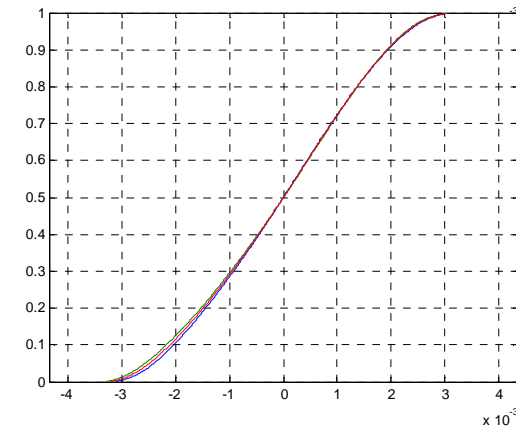
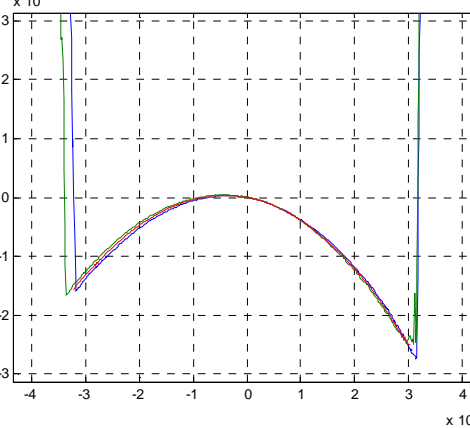
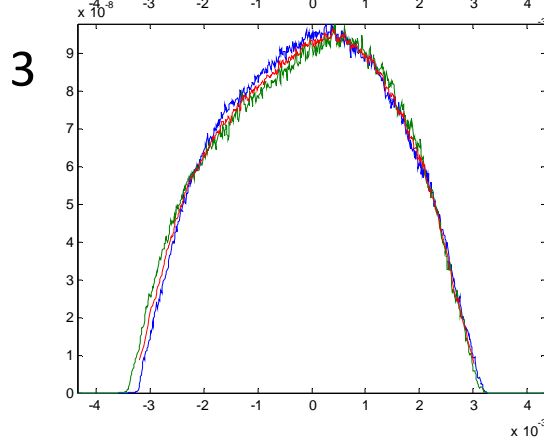
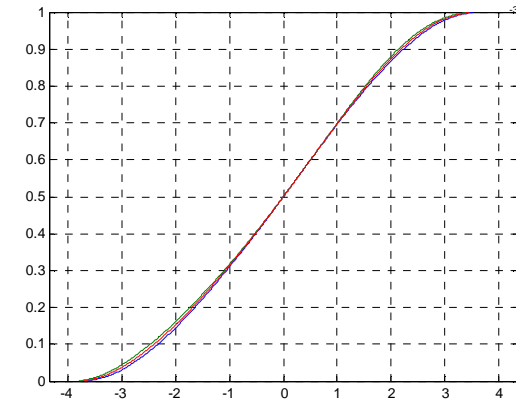
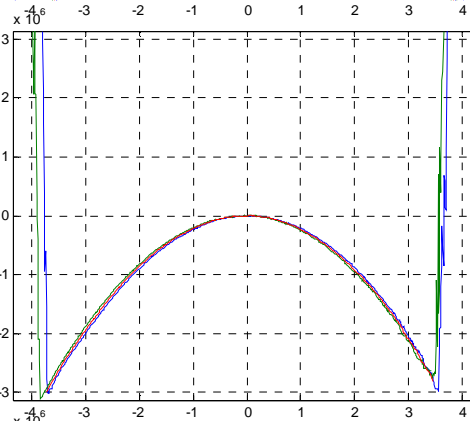
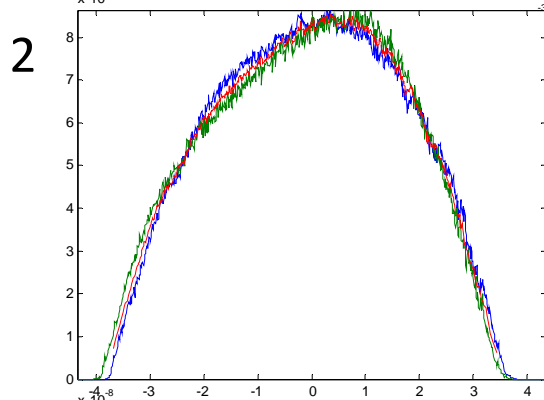
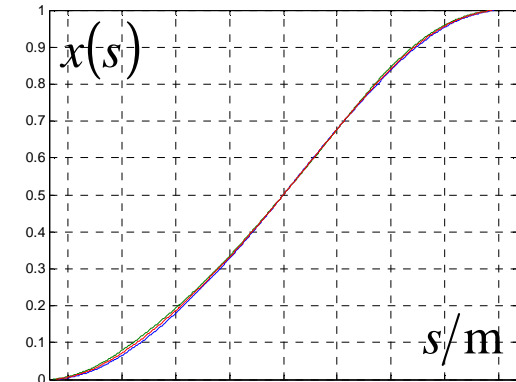
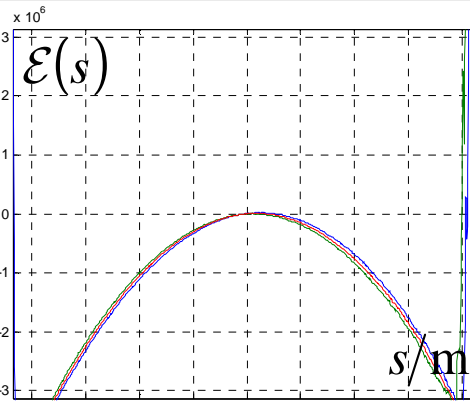
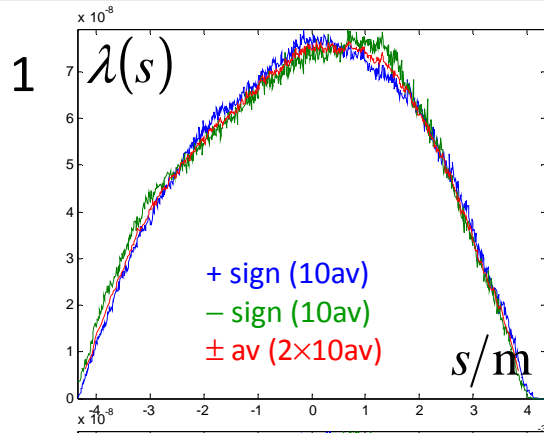

5 Measurements (1-9)

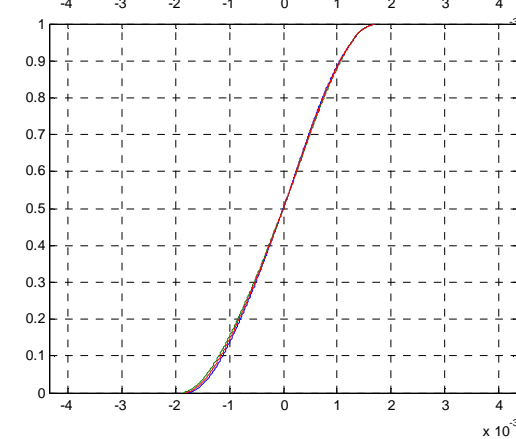
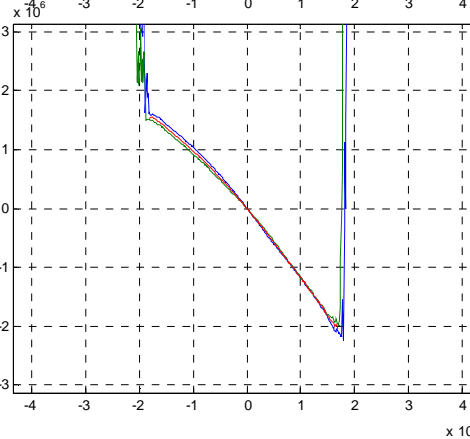
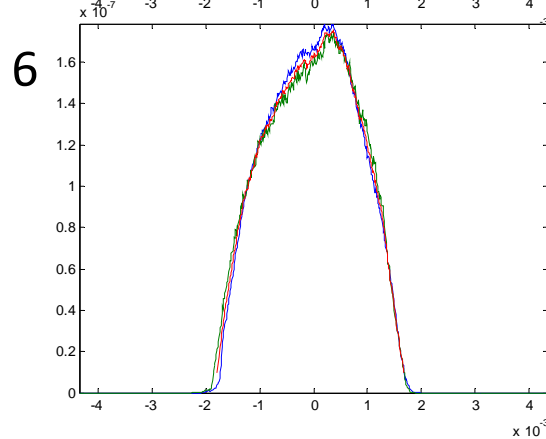
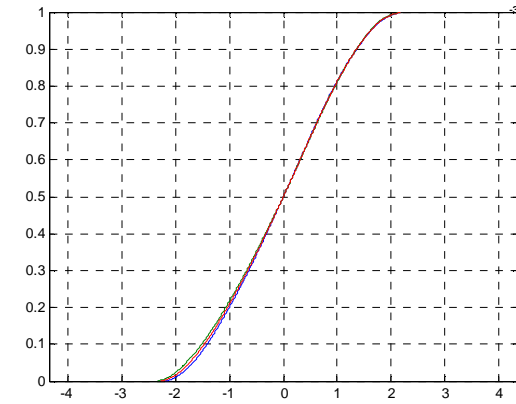
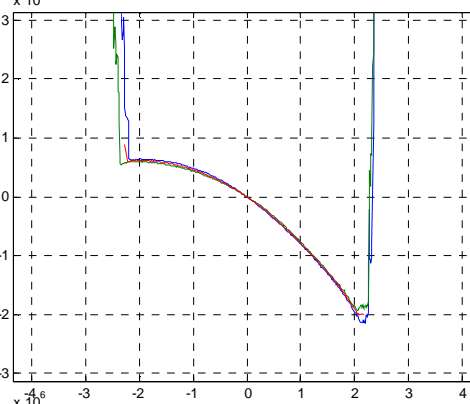
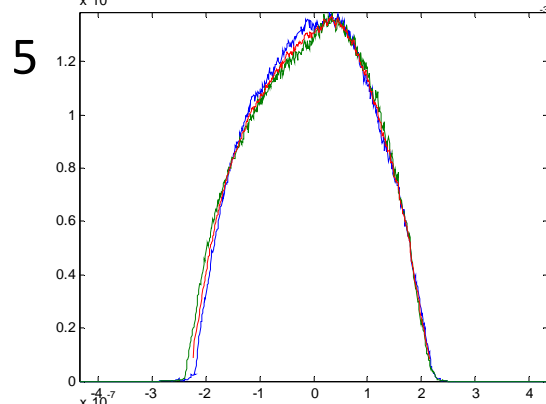
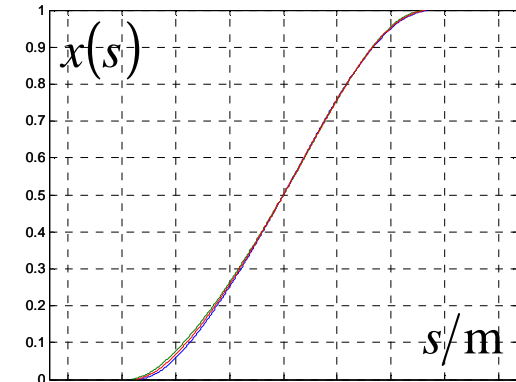
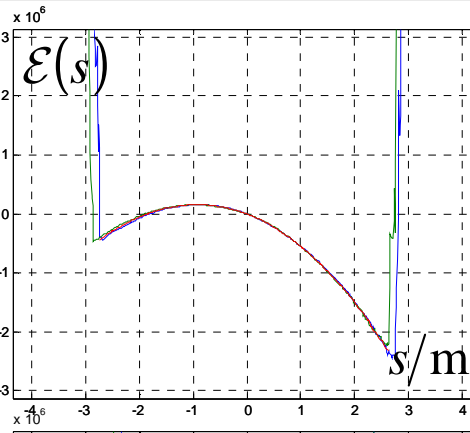
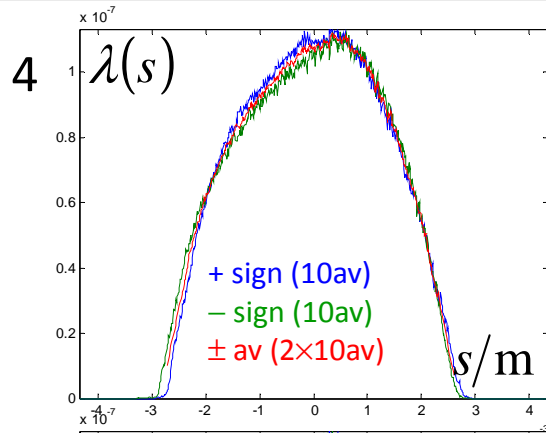

5 Measurements (1-9)

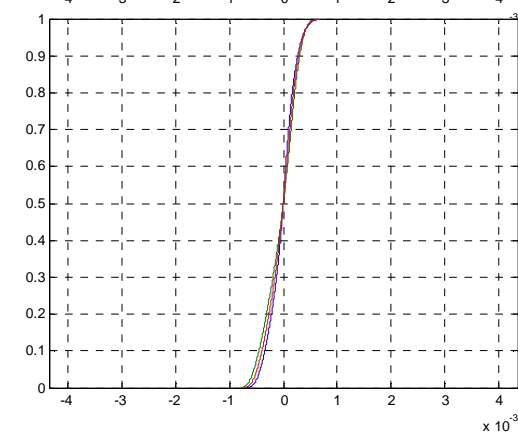
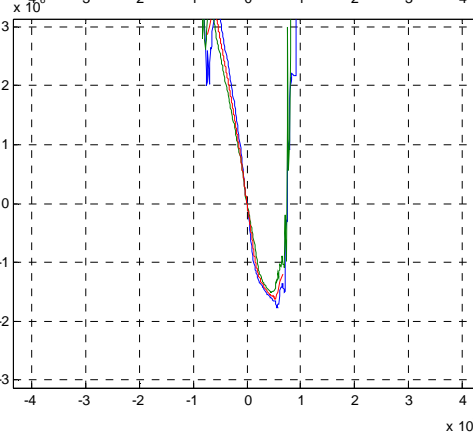
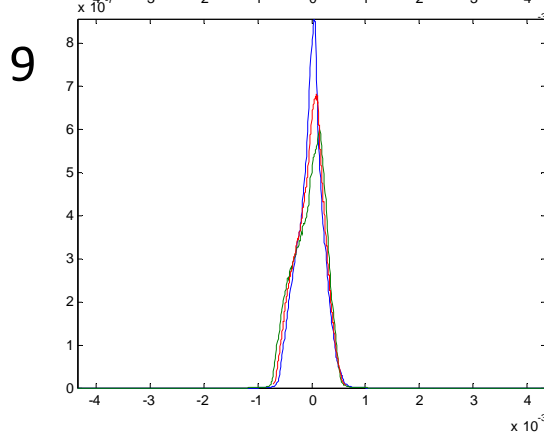
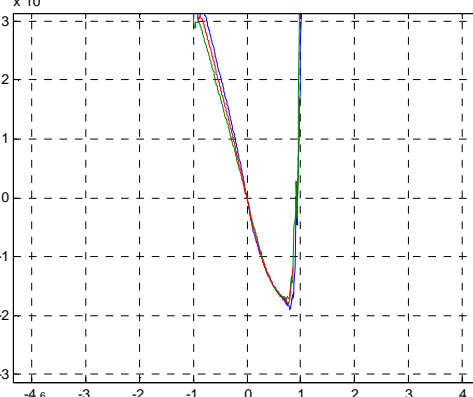
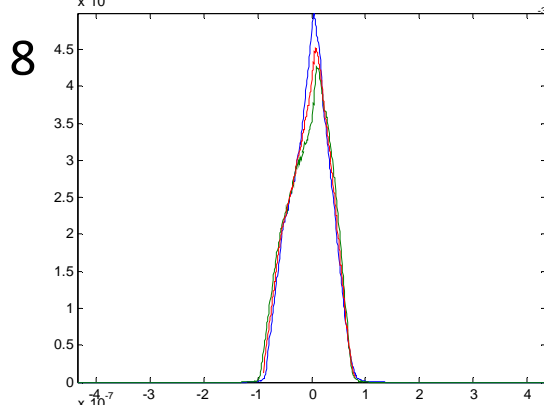
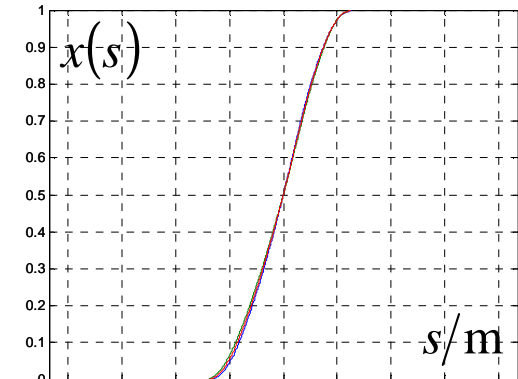
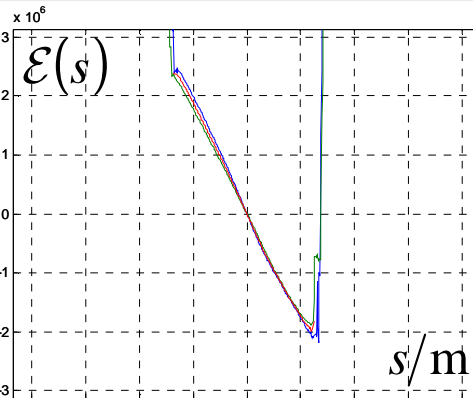
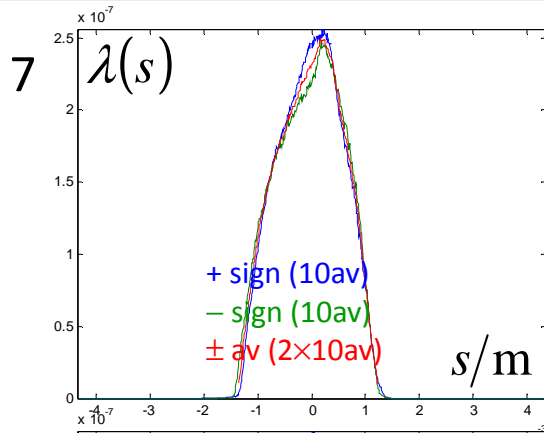

5 Measurements (1-9)

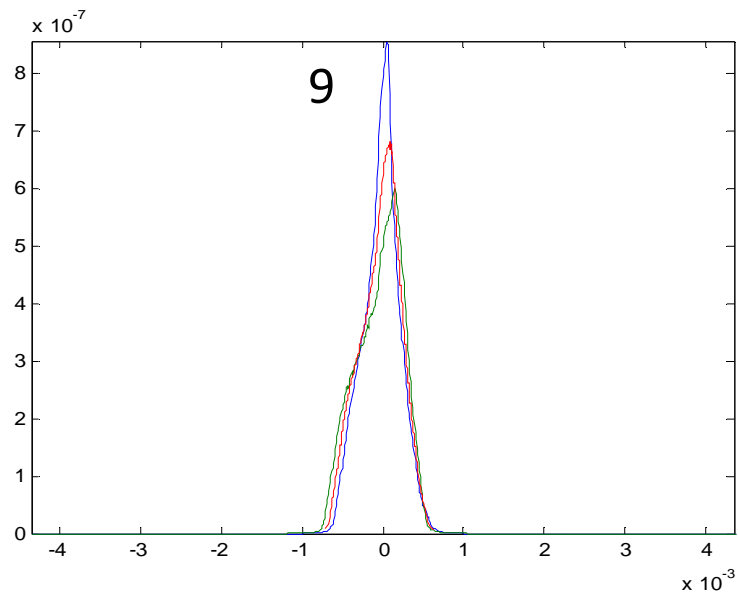
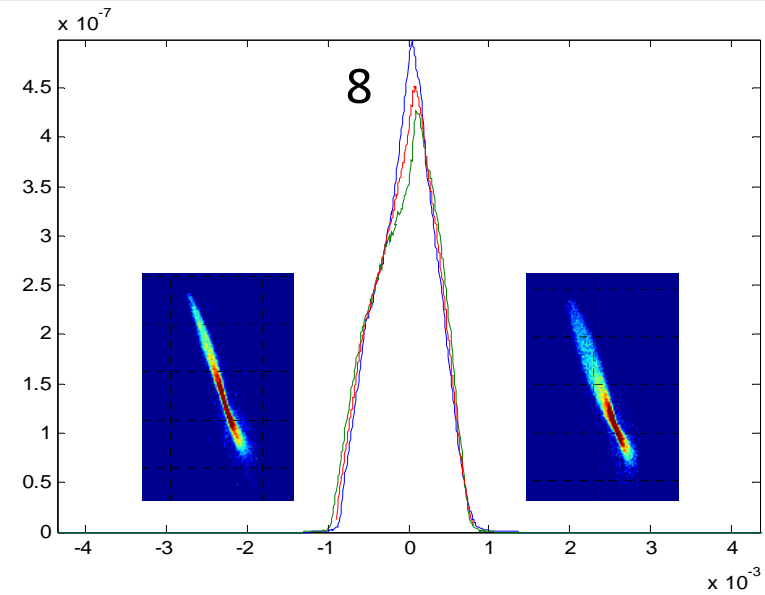
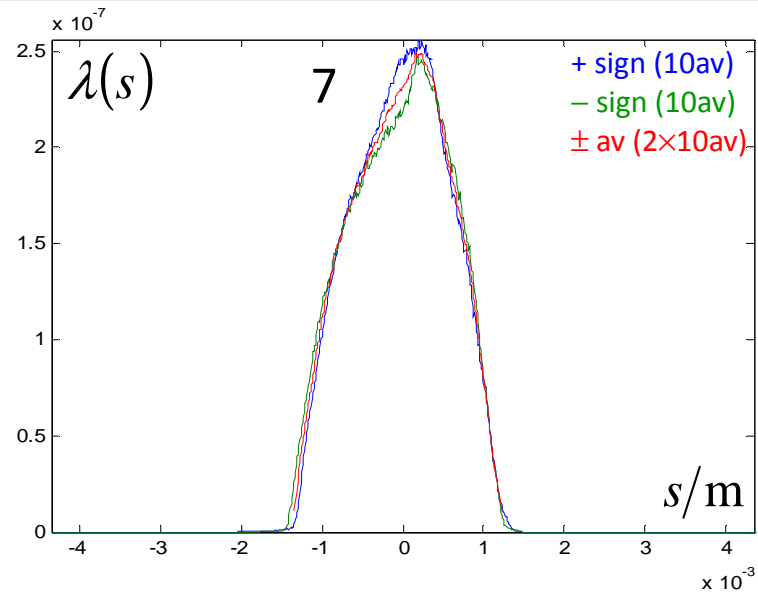

6 Compression

calculation of compression factor: Ca=differential, + sign (10av)
Cb=differential, - sign (10av)
Cc=differential, ± av (2×10av)
Cd=rms ratio, lambda(2×10av)

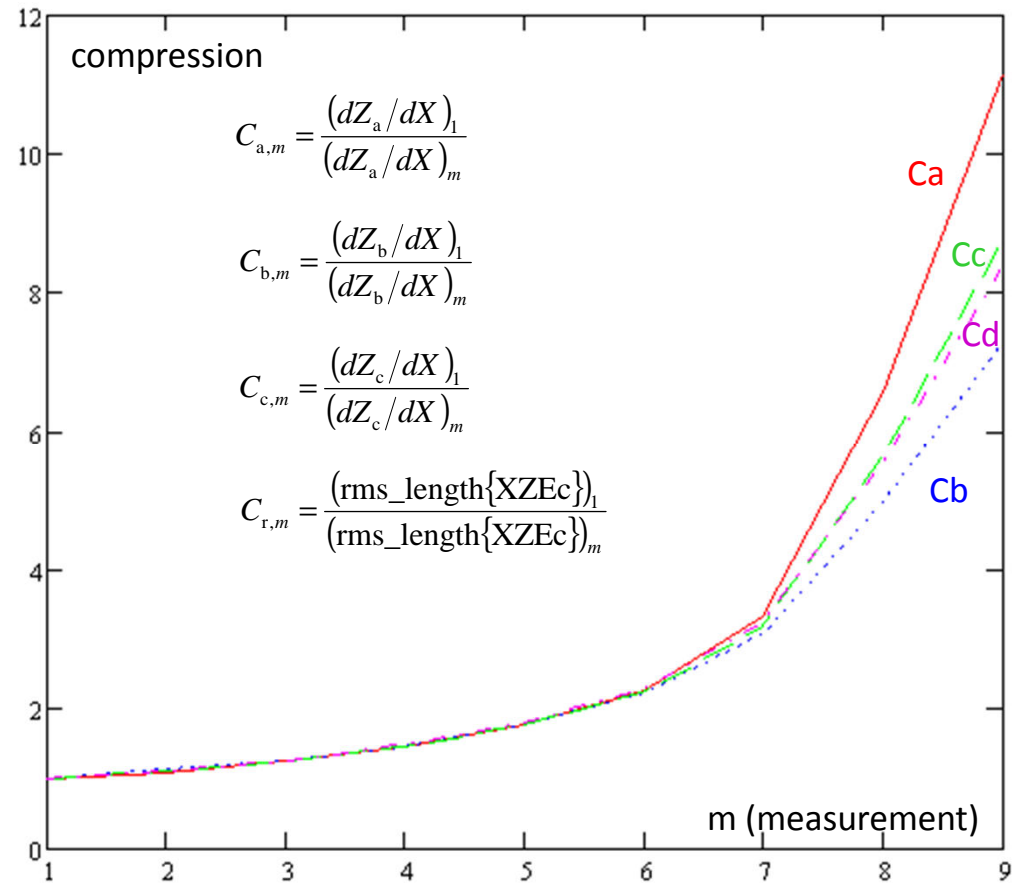

6 Compression

calculation of compression factor:
Ca=differential, + sign (10av)
Cb=differential, - sign (10av)
Cc=differential, ± av (2×10av)
Cd=rms ratio, lambda(2×10av)

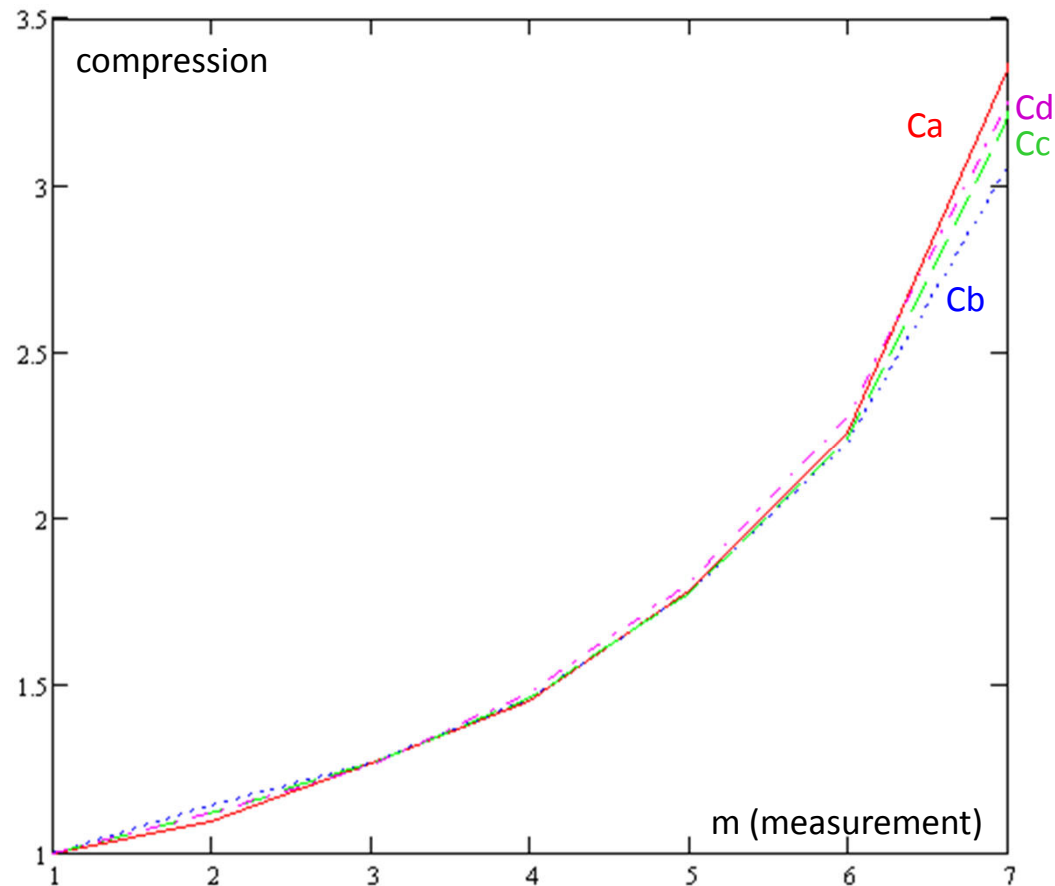

6 Compression

theoretical fit: only one free parameter! (depends on r_{56} and slope of initial distribution)

$$p_m = p_{m,rf} + p_b = \frac{e \frac{d}{ds} V(s, \text{rf_parameters}) + \frac{d}{ds} \mathcal{E}_{\text{bunch}}}{\mathcal{E}_{\text{nominal}}}$$

ACC1, ACC39

“virtual” before ACC1

$$p_{1,rf} = 0 \text{ m}^{-1}$$

$$r_{56} = r_{56,\text{nominal}}$$

$$p_b$$

↓

$$\tilde{r}_{56} = \frac{r_{56}}{1 + p_b r_{56}}$$

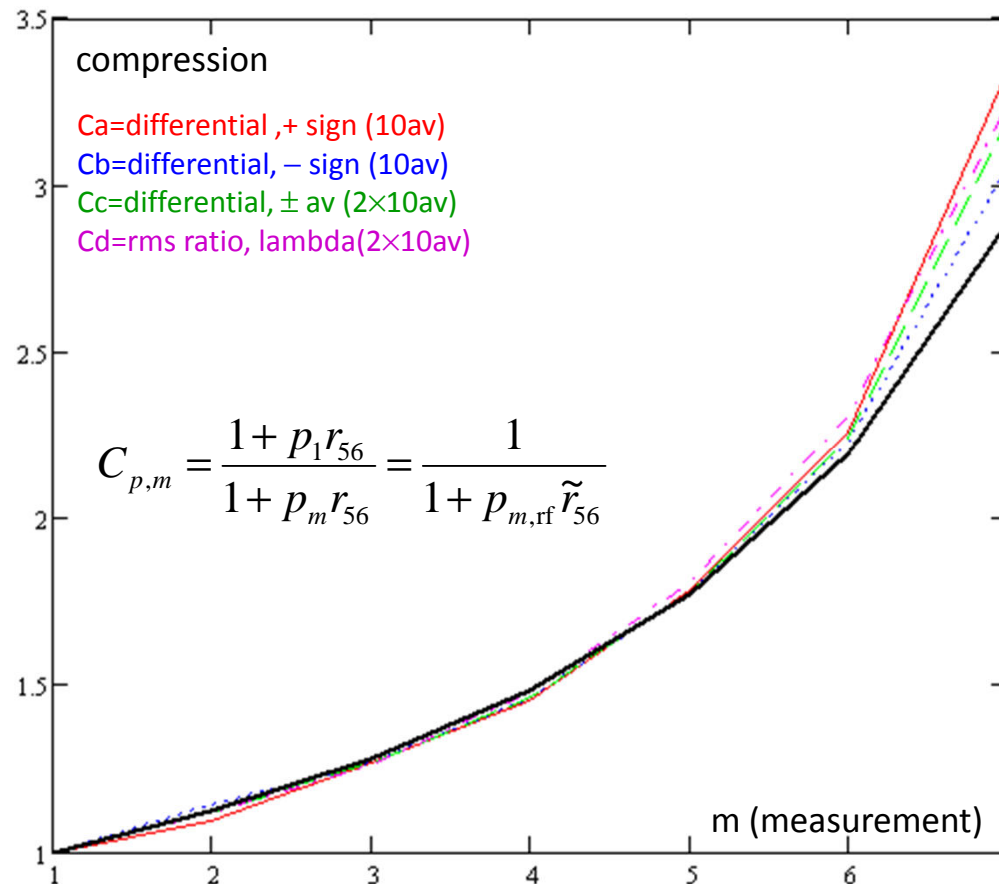

6 Compression

theoretical fit: not too good for measurement 6, 7, ...

$$p_b \approx 0.89 \text{ m}^{-1}$$

$$(p_{m,rf}) \approx \begin{pmatrix} 0 \\ -0.71 \\ -1.41 \\ -2.12 \\ -2.83 \\ -3.54 \\ -4.25 \\ -4.96 \\ -5.32 \end{pmatrix} \text{ m}^{-1}$$

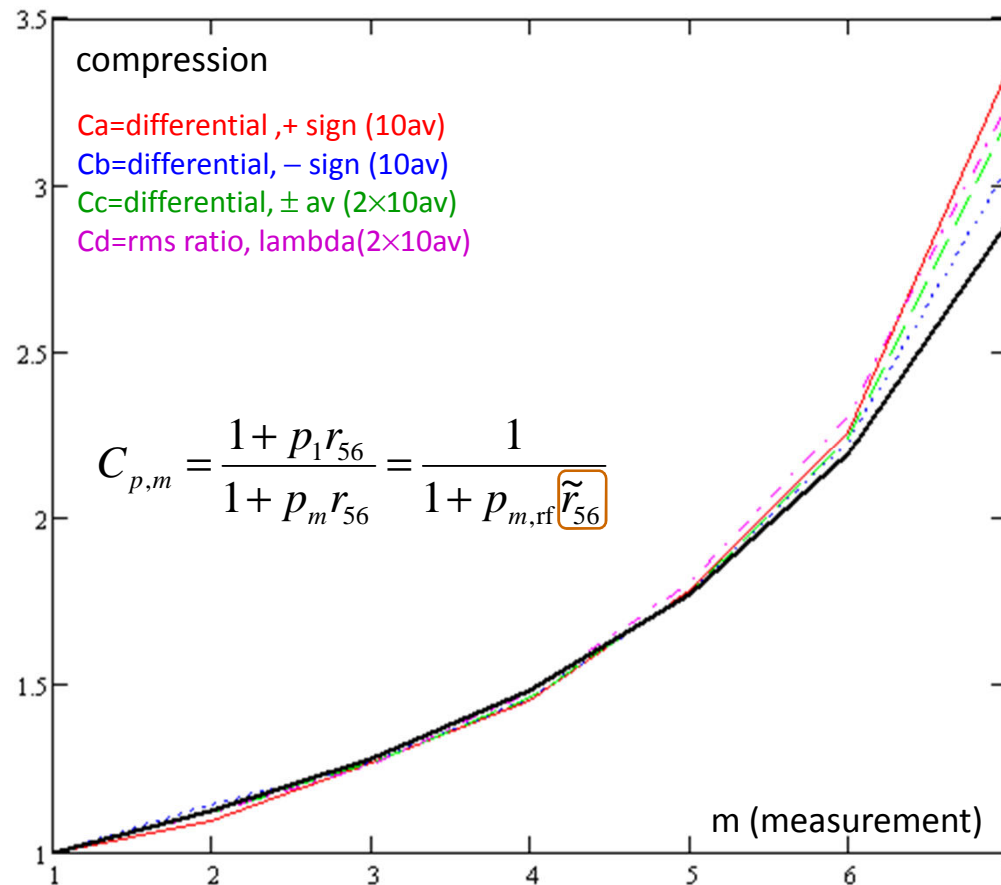

7 Reconstruction

two point reconstruction (time-time method):

measurement m $S_m(x) = S(x) + D\{\mathcal{E}(x) + \mathcal{E}_{\text{rf},m}(S(x))\}$

measurement n $S_n(x) = S(x) + D\{\mathcal{E}(x) + \mathcal{E}_{\text{rf},n}(S(x))\}$

unknown "virtual" initial condition

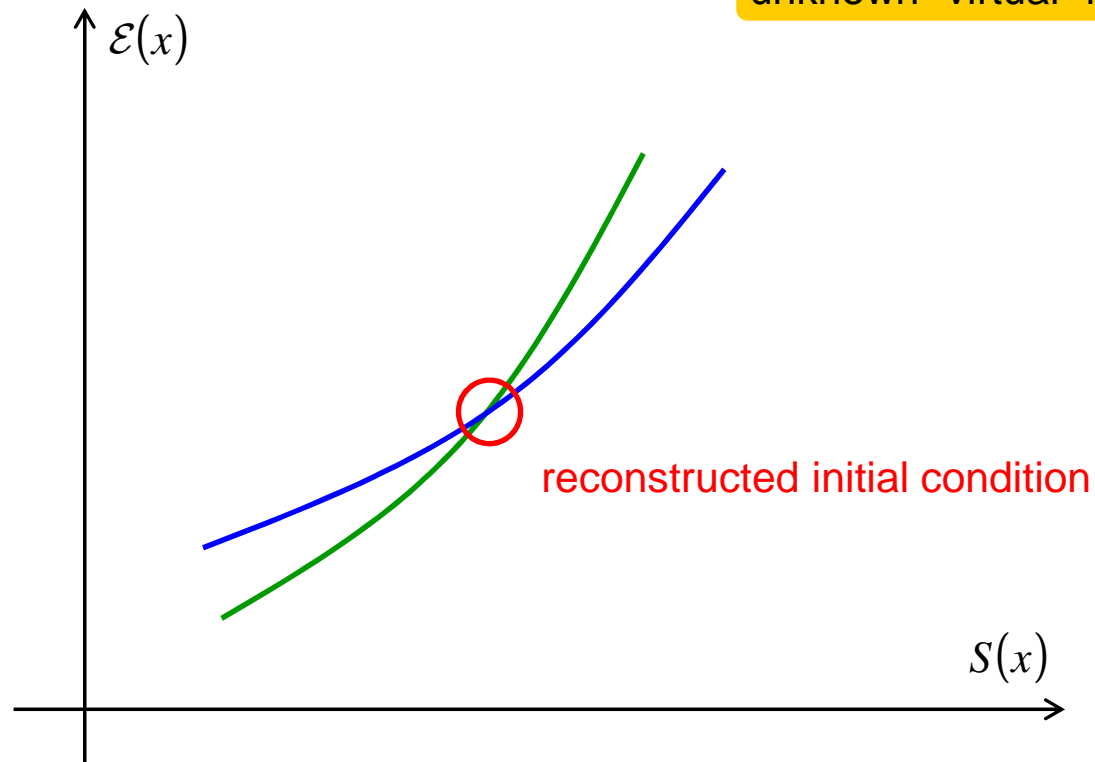

7 Reconstruction (2 point)

measurements 2 and 6!

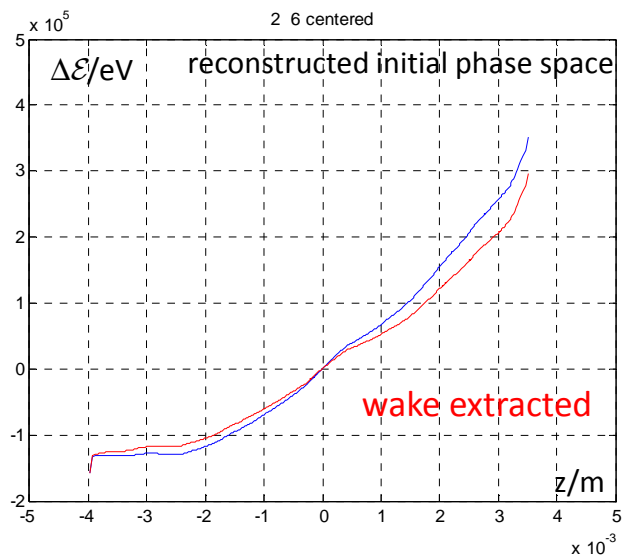
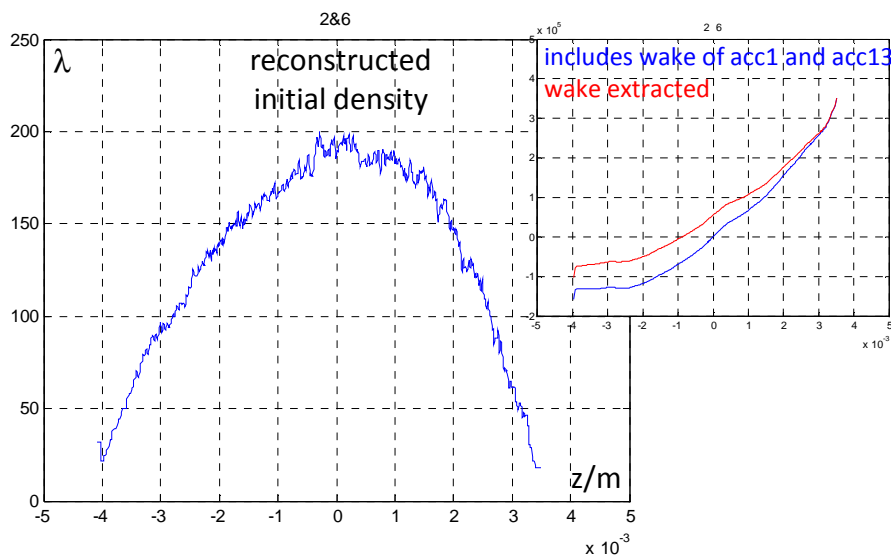
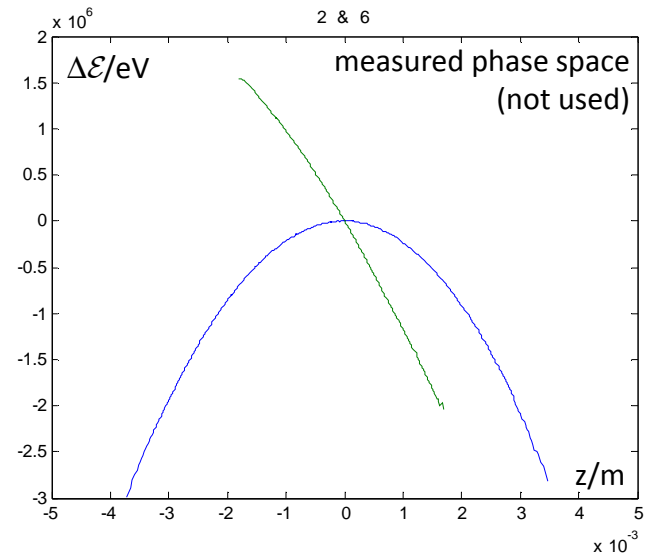
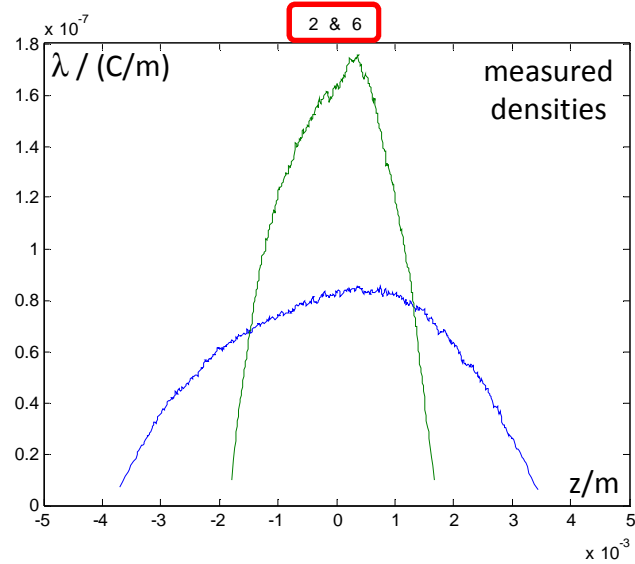

7 Reconstruction (2 point)

measurements 1 and 5!

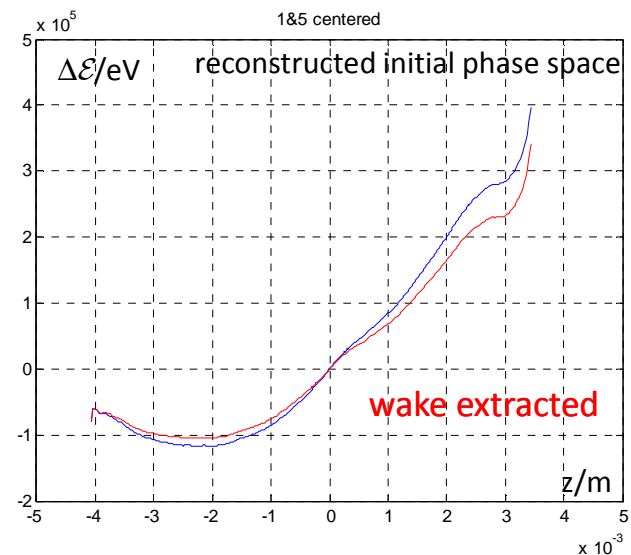
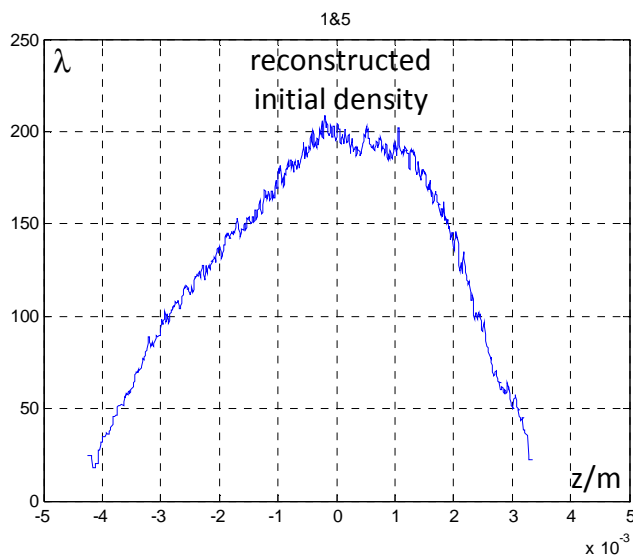
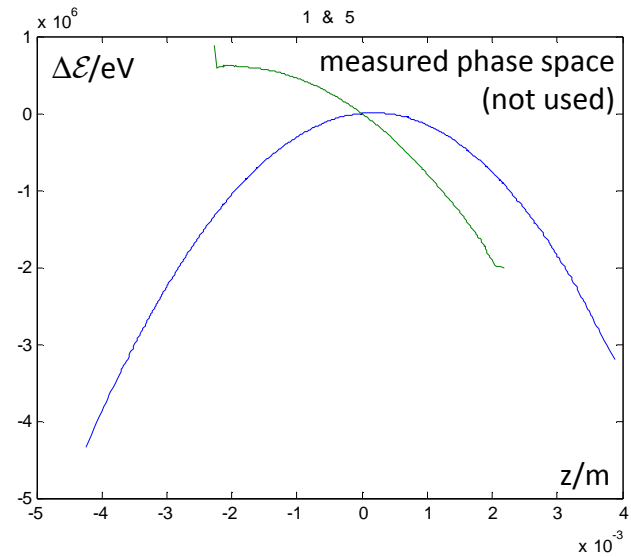
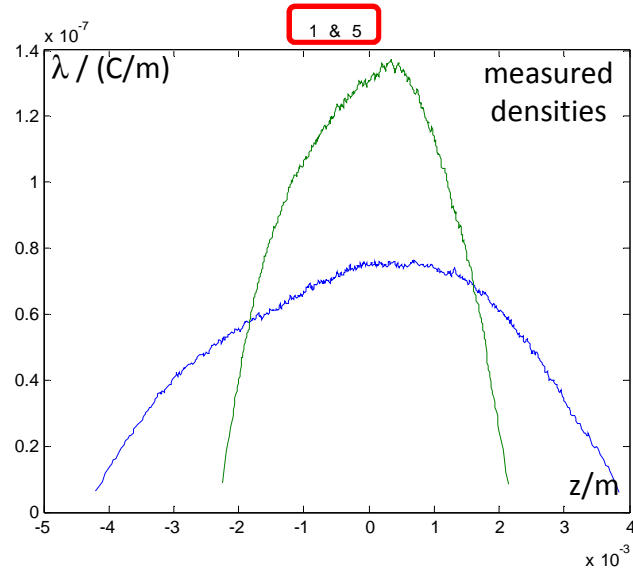

7 Reconstruction (2 point)

more combinations:

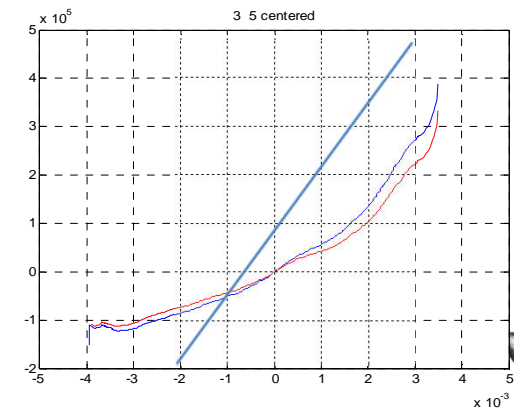
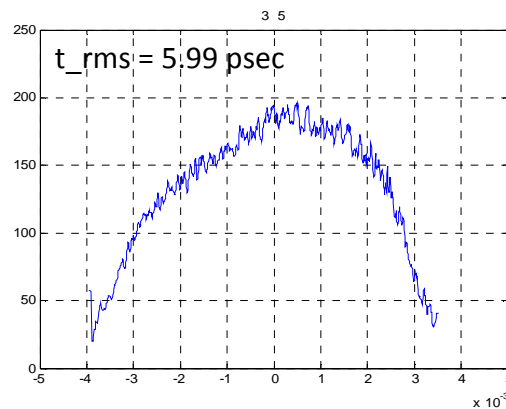
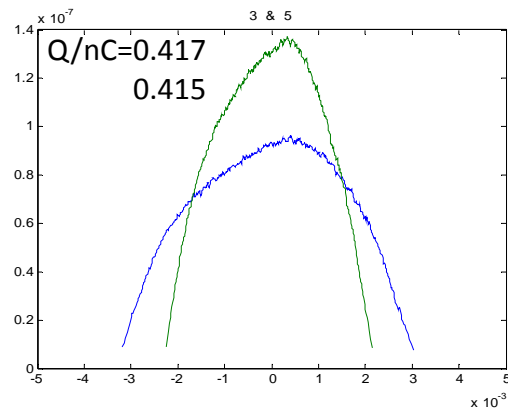
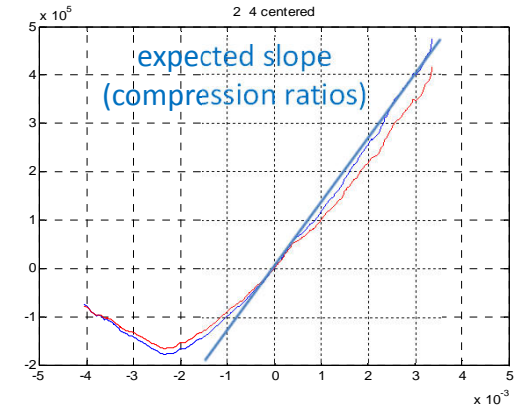
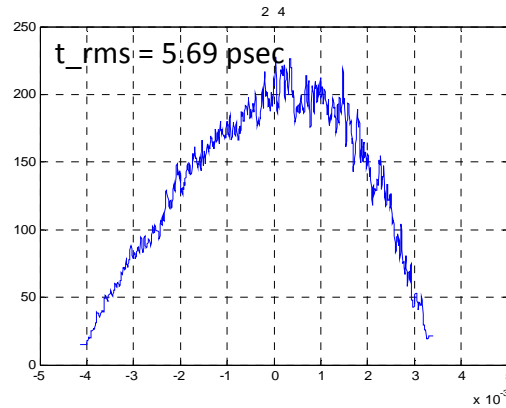
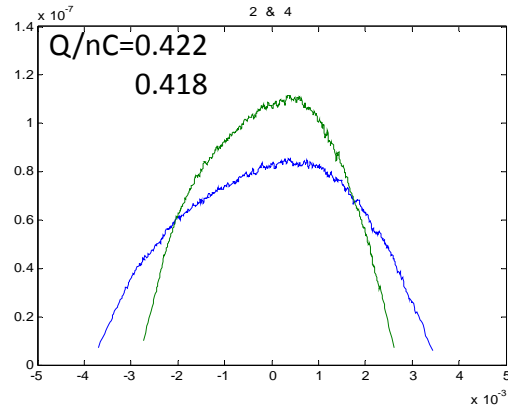
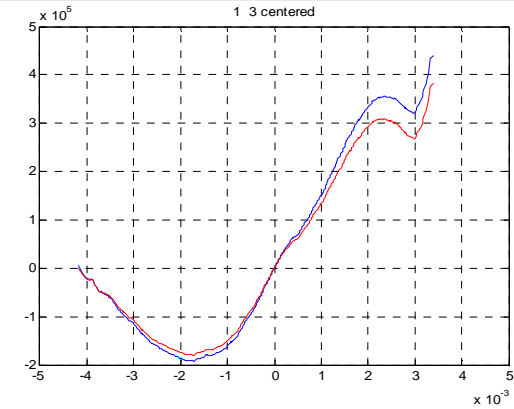
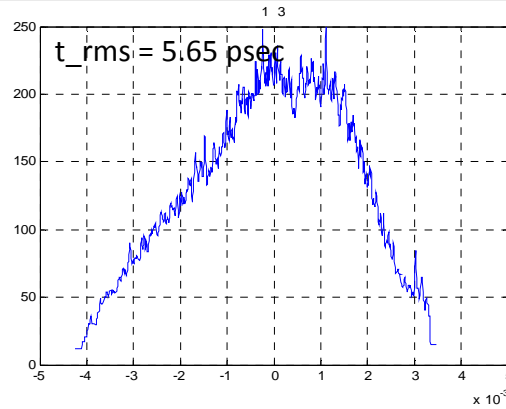
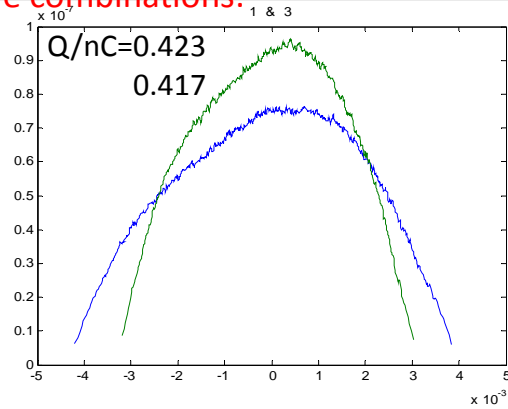

7 Reconstruction (2 point)

more combinations: uncertain results for measurements with high compression ratio
week results for measurements with small difference in rf-settings

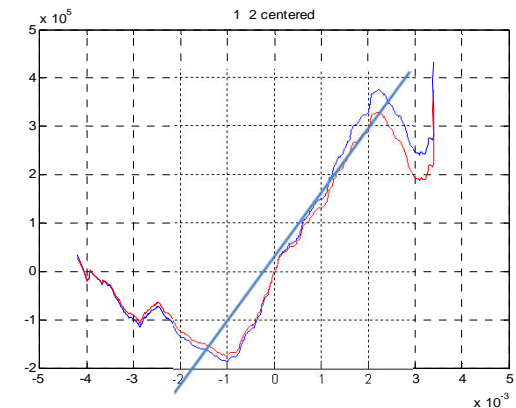
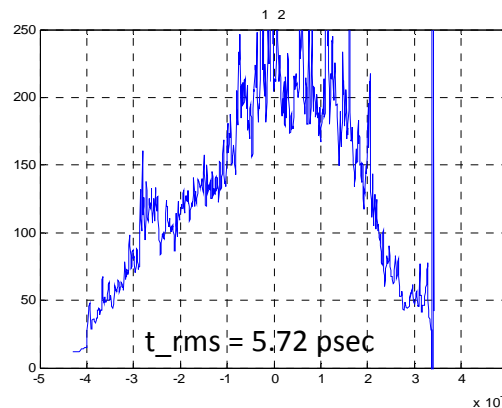
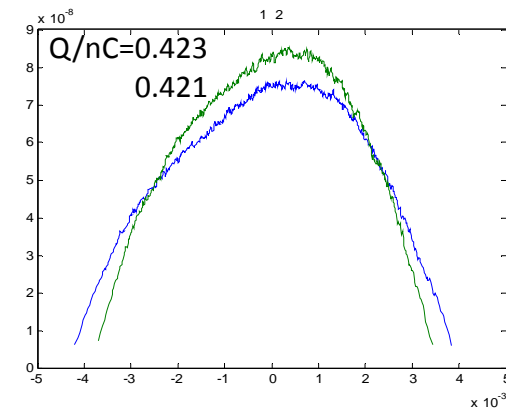
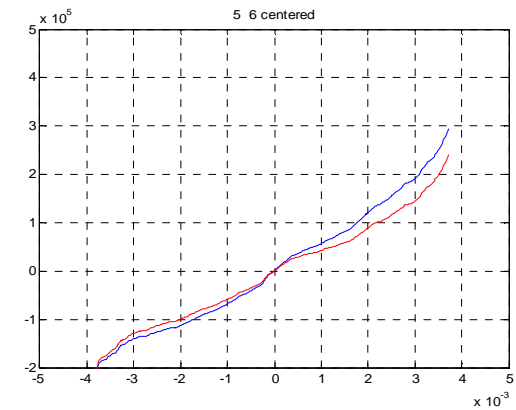
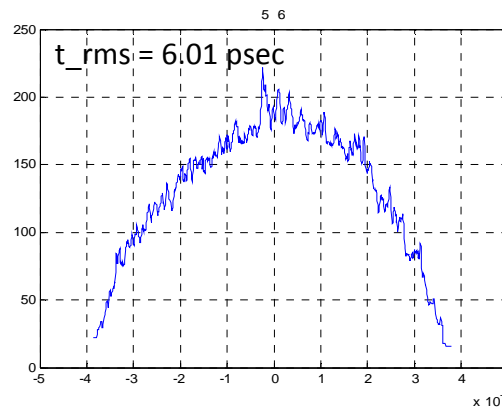
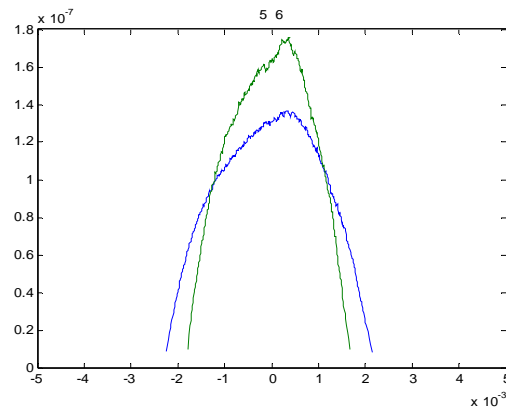

7 Reconstruction

multi point reconstruction (time-time method):

measurement m_1 $S_{m_1}(x) = S(x) + D\{\mathcal{E}(x) + \mathcal{E}_{\text{rf},m_1}(S(x))\}$

measurement m_2 $S_{m_2}(x) = S(x) + D\{\mathcal{E}(x) + \mathcal{E}_{\text{rf},m_2}(S(x))\}$

measurement m_3 $S_{m_3}(x) = S(x) + D\{\mathcal{E}(x) + \mathcal{E}_{\text{rf},m_3}(S(x))\}$

...

unknown "virtual" initial condition

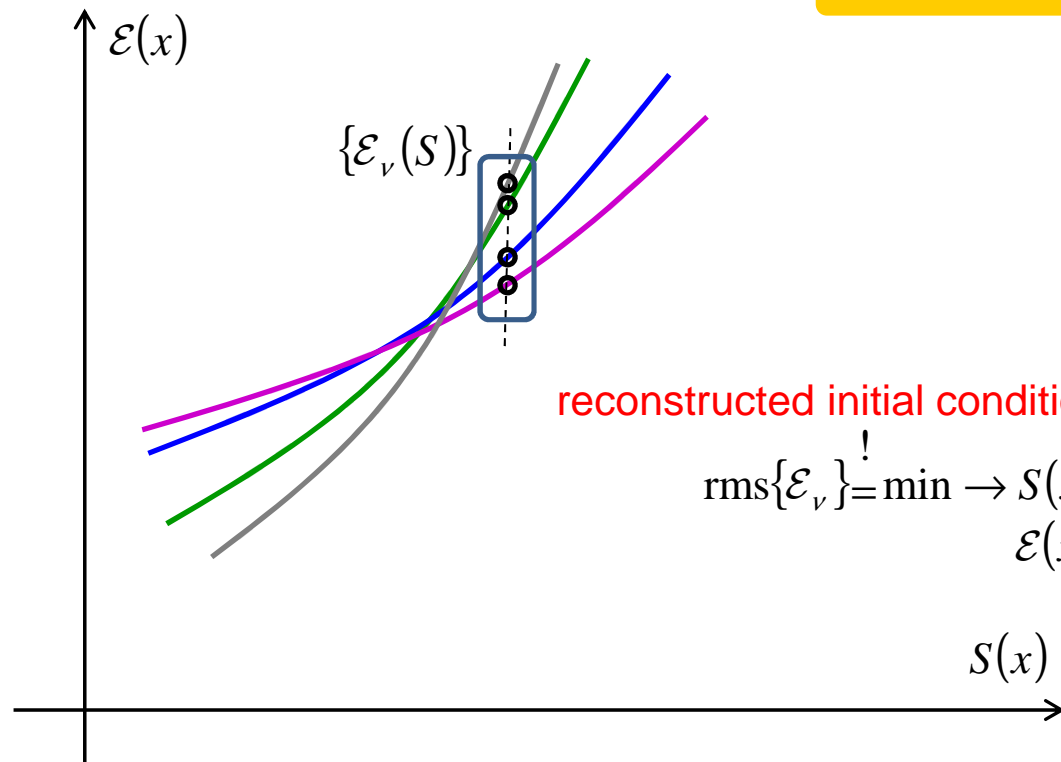

7 Reconstruction (multi)

some combinations:

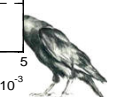
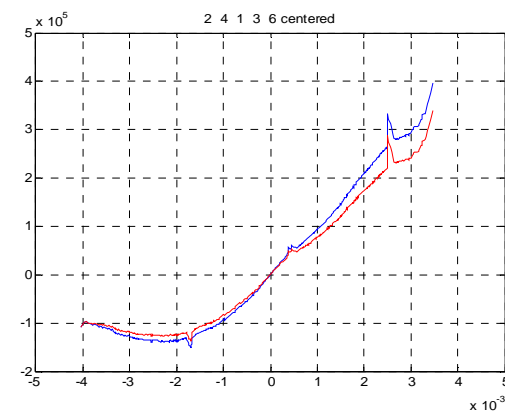
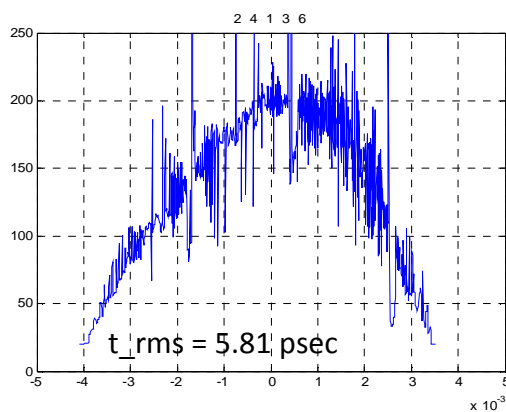
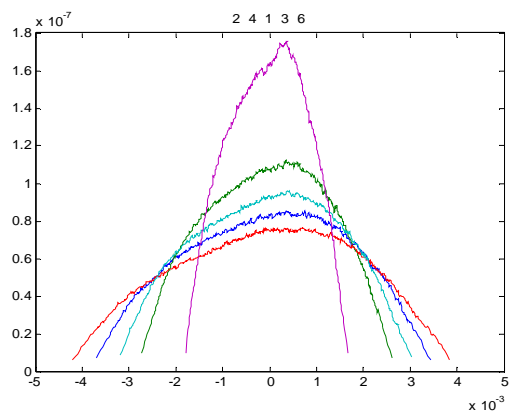
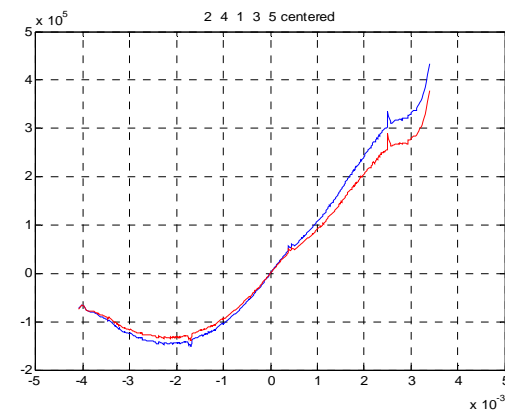
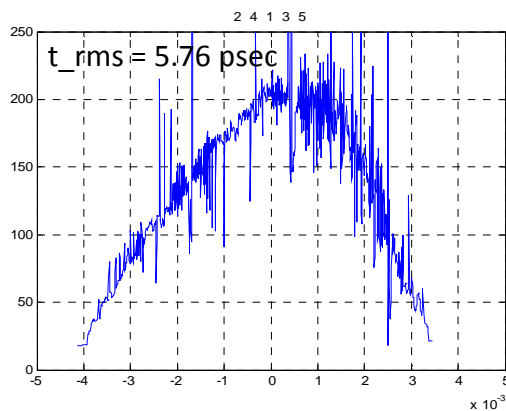
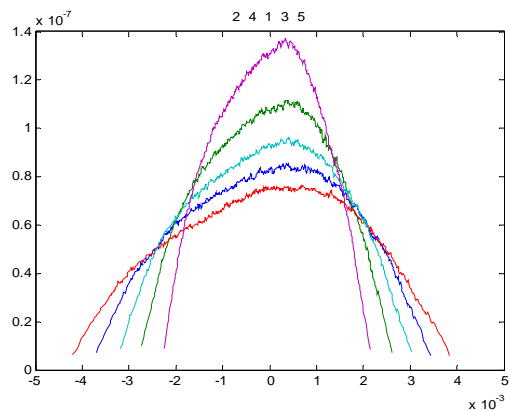
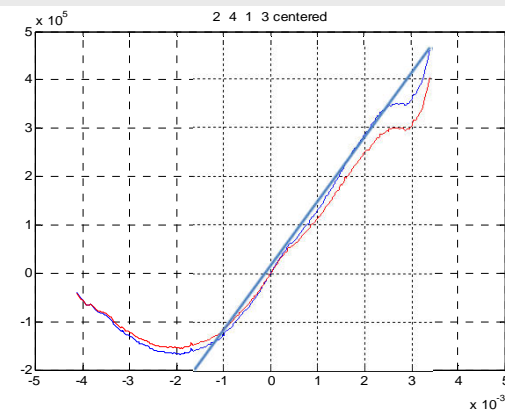
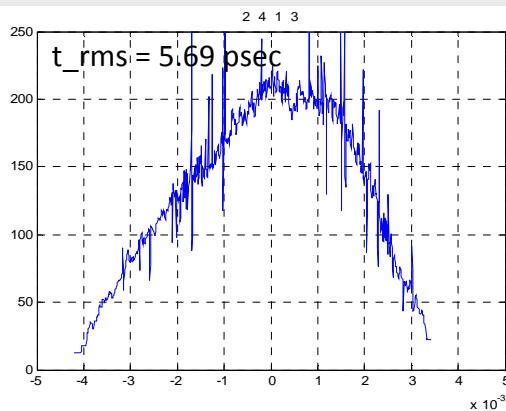
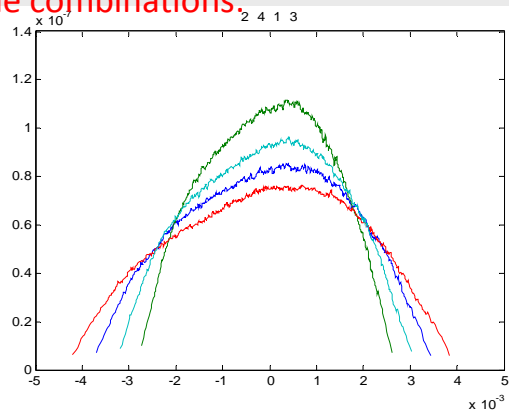

8 Initial Distribution

virtual initial distribution used for rf-tweak simulation:

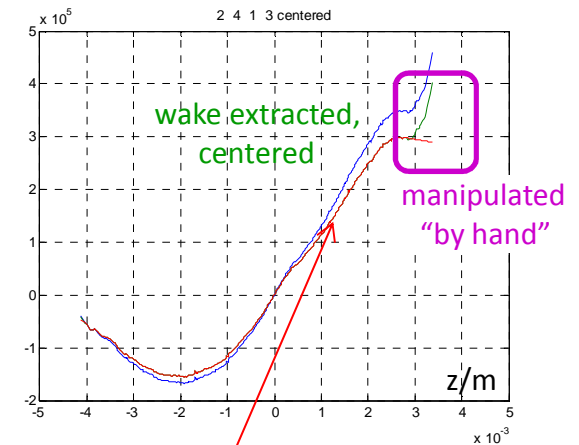
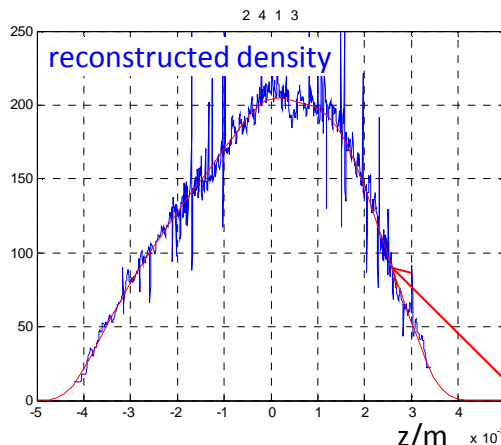
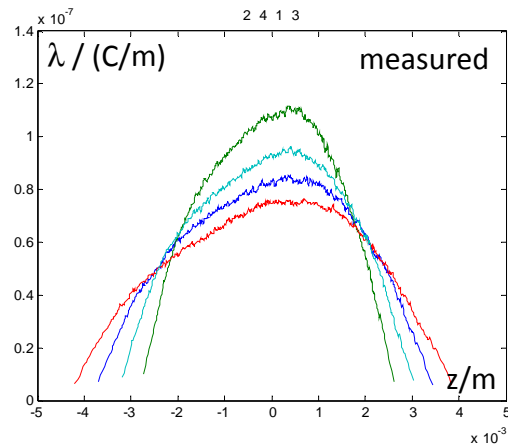
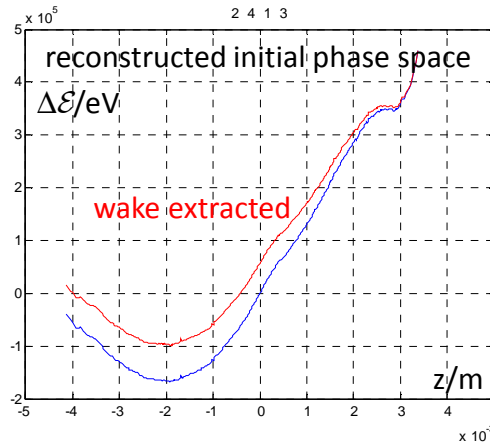
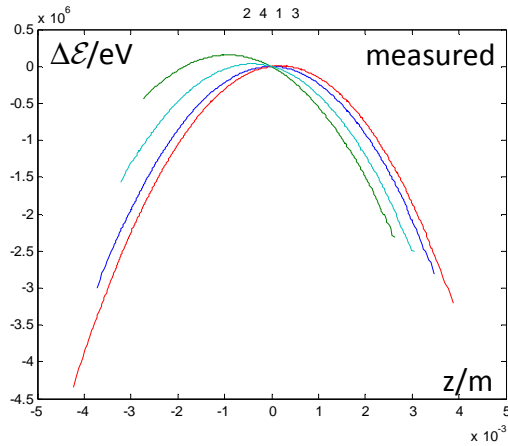

smoothed
for rf-tweak simulation



8 Initial Distribution

comparison with old measurement

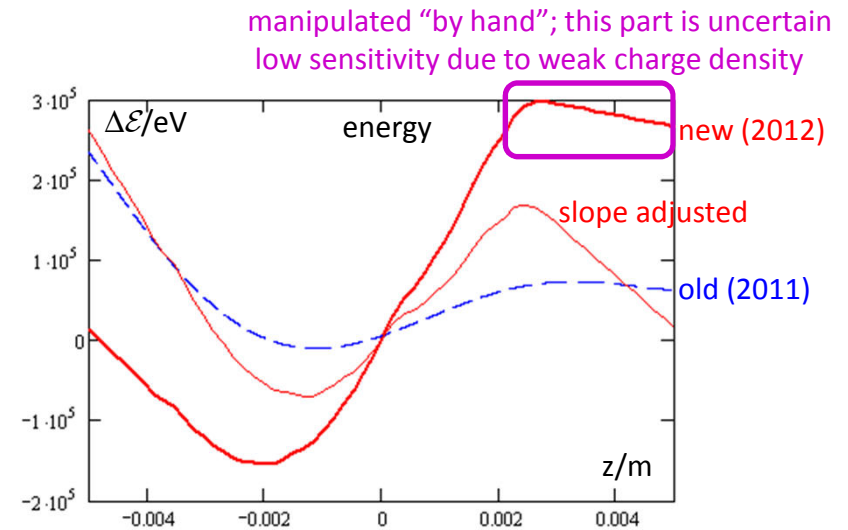
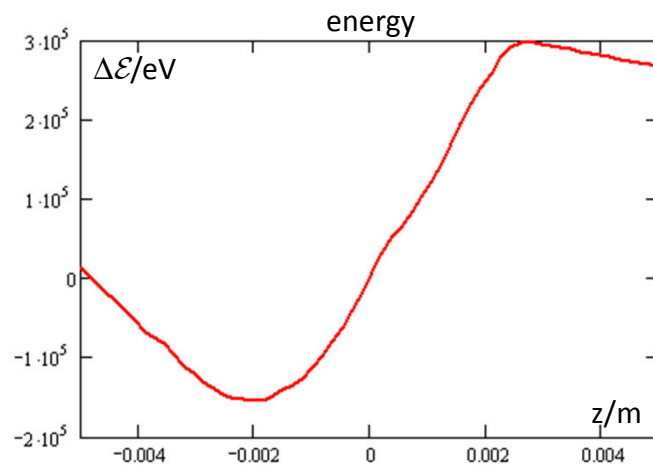
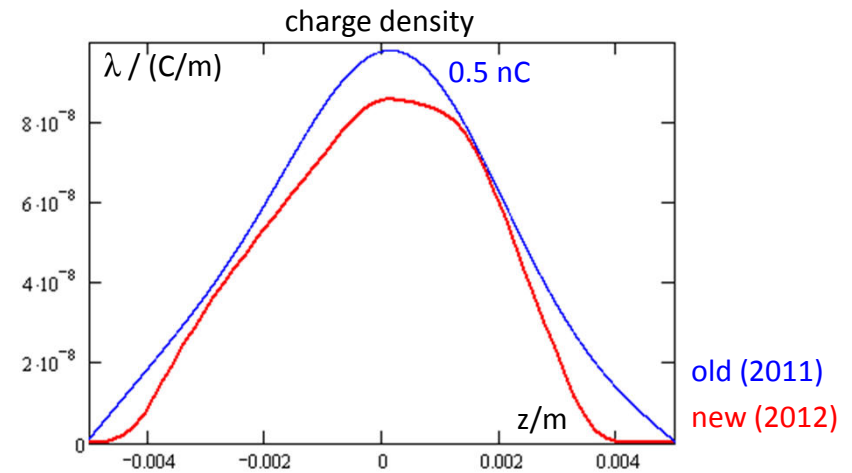
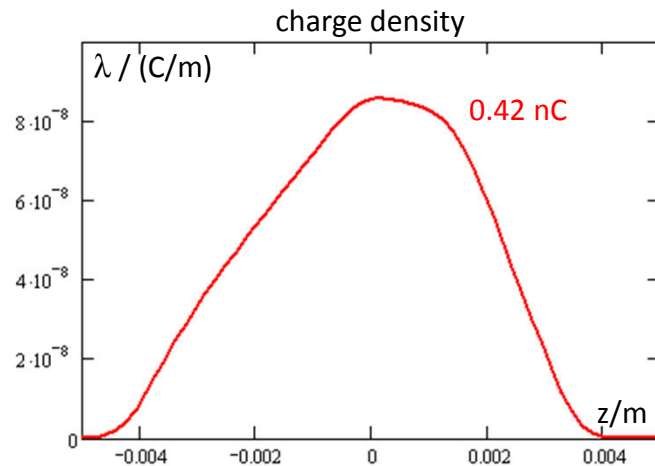

9 RF-Tweak Simulation

the following simulation consider SC, CSR and **cavity wakes**

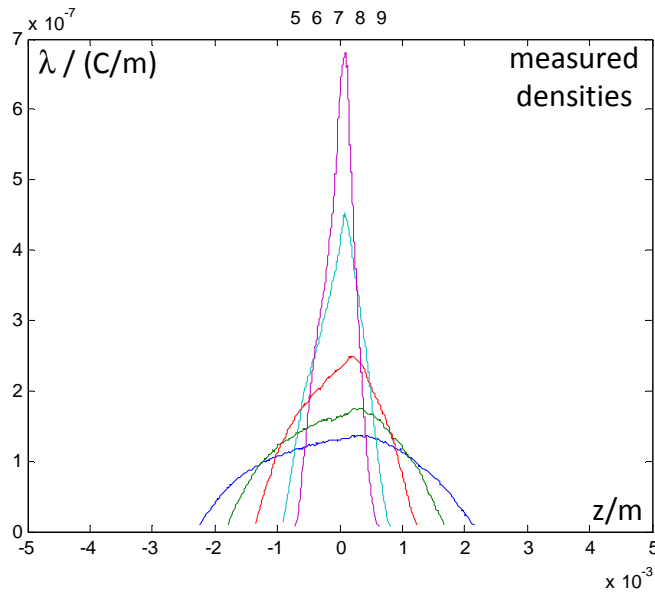
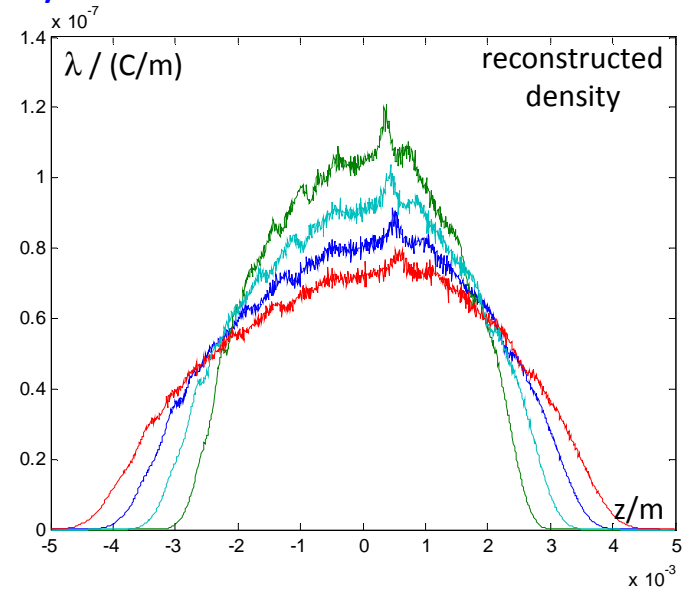
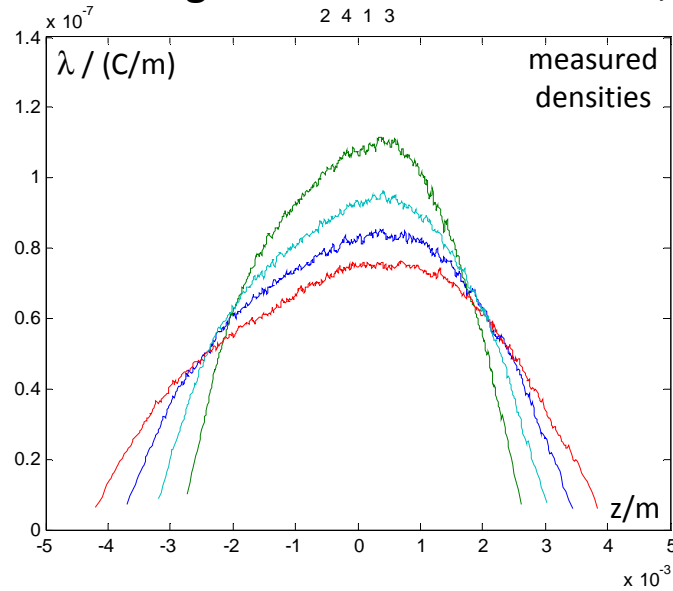

not too good
for higher
compression
ratio !

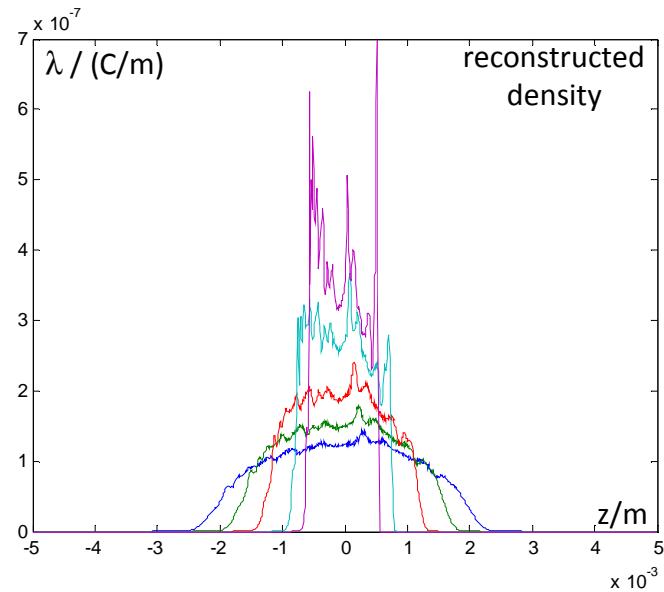

9 RF-Tweak Simulation

the following simulation consider SC, CSR and **cavity wakes**

longitudinal phase space

the LOLA energy scale was not used for reconstruction!

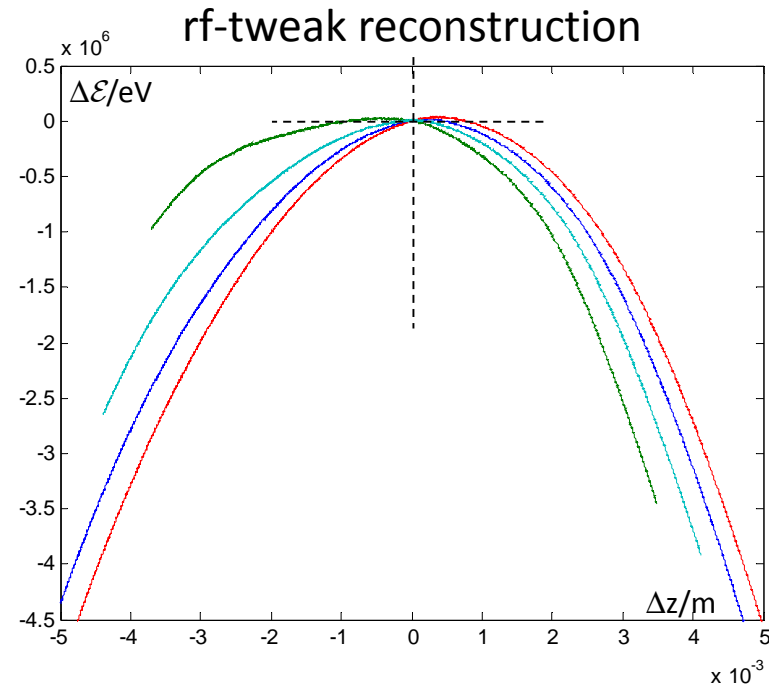
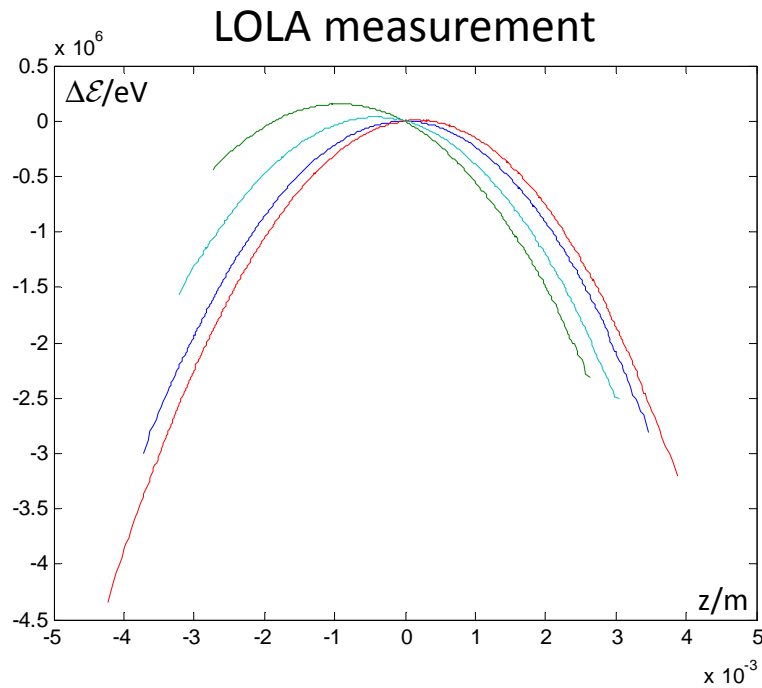

9 RF-Tweak Simulation

the following simulation consider SC, CSR and **cavity wakes**

longitudinal phase space

the LOLA energy scale was not used for reconstruction!

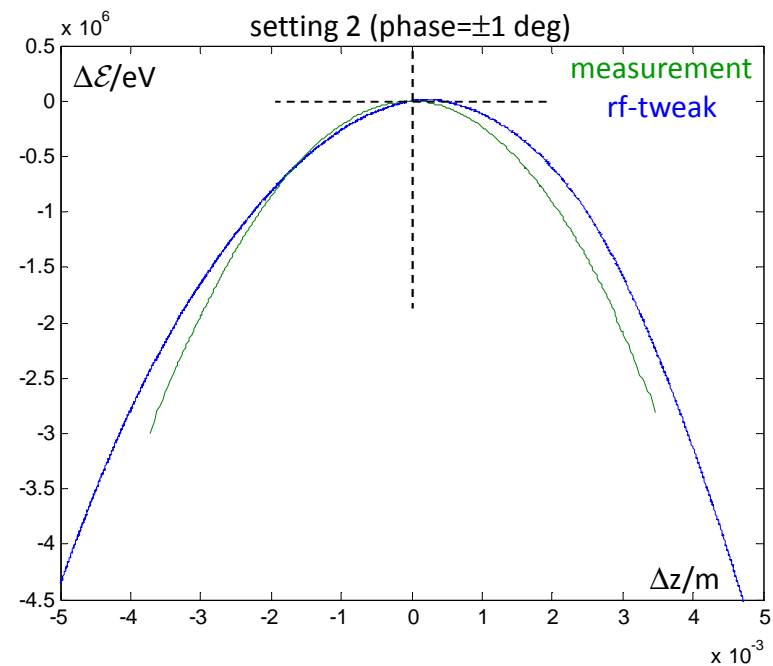
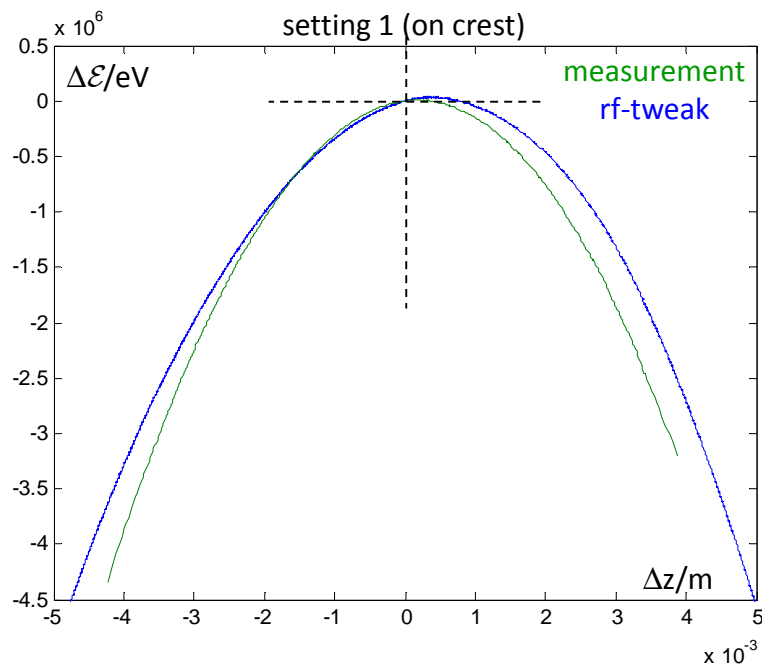

9 RF-Tweak Simulation

the following simulation consider SC, CSR and [cavity wakes](#)

longitudinal phase space

the LOLA energy scale was not used for reconstruction!

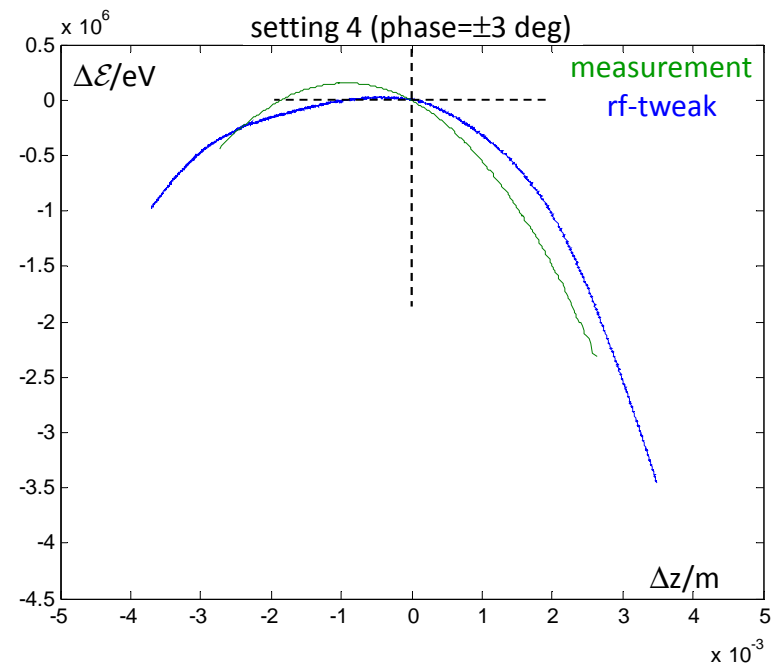
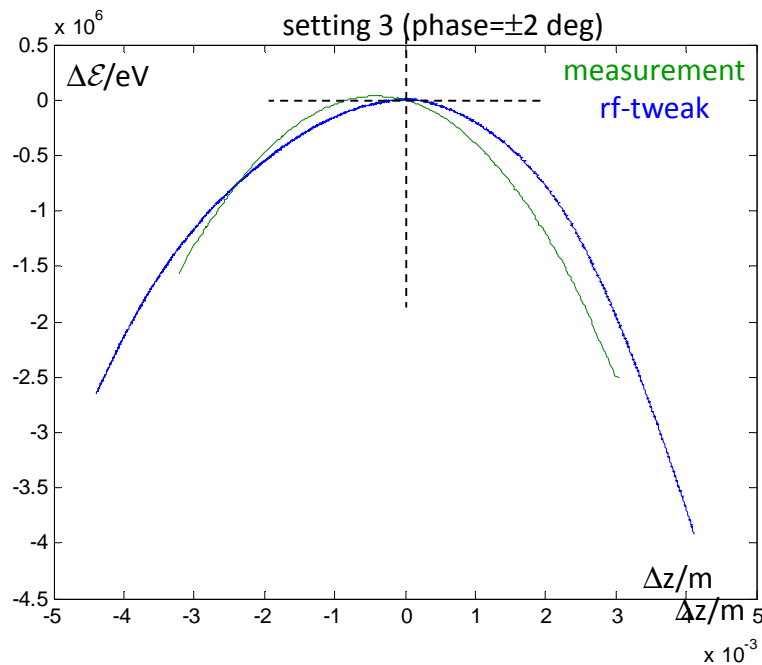

10 Wakes from Database

new wake-files from database (in Astra format)

```
wkfile0='03may2012\GUN_BC2.dat';    % before BC2
wkfile1='03may2012\BC2_BC3.dat';    % after BC2, before BC3
wkfile2='03may2012\BC3_ECOL.dat';   % after BC3, before ECOL
wkfile3='03may2012\ECOL.dat';       % ECOL
wkfile4='03may2012\ECOL_LOLA.dat';  % after ECOL, before LOLA
```

used for reconstruction and rf-tweak
→ cancels out

after reconstruction point:
needed for rf-tweak

underestimated wake

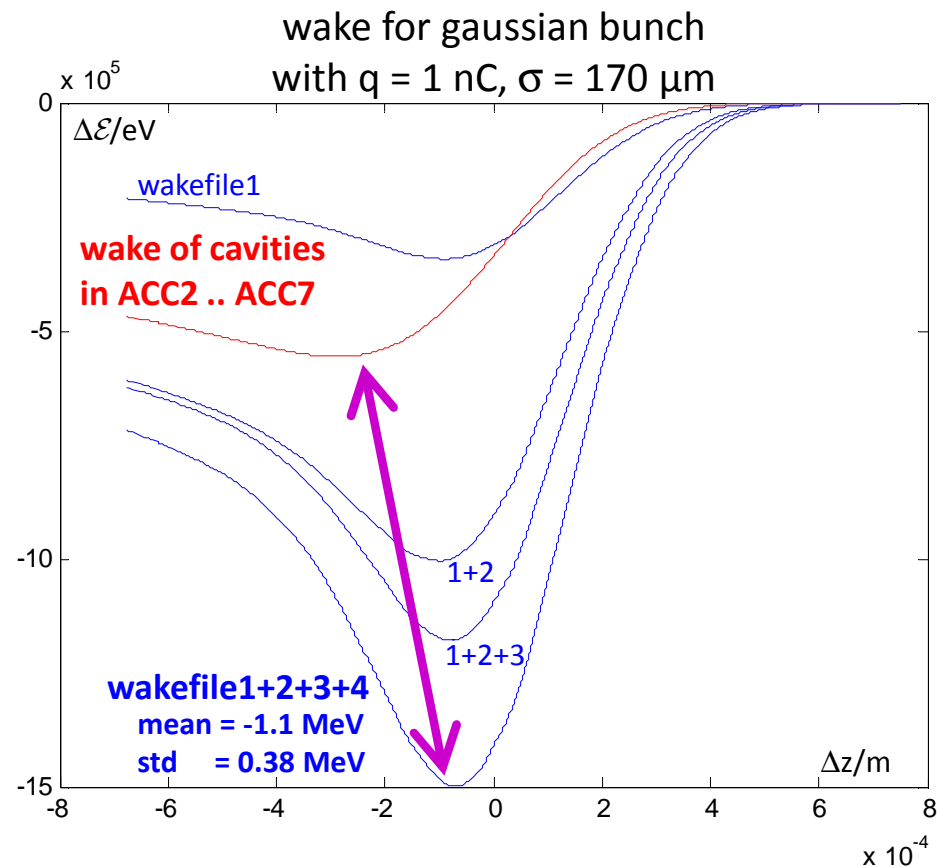

10 Wakes from Database

for measurements 1..9 the longitudinal phase space figure does not change too much

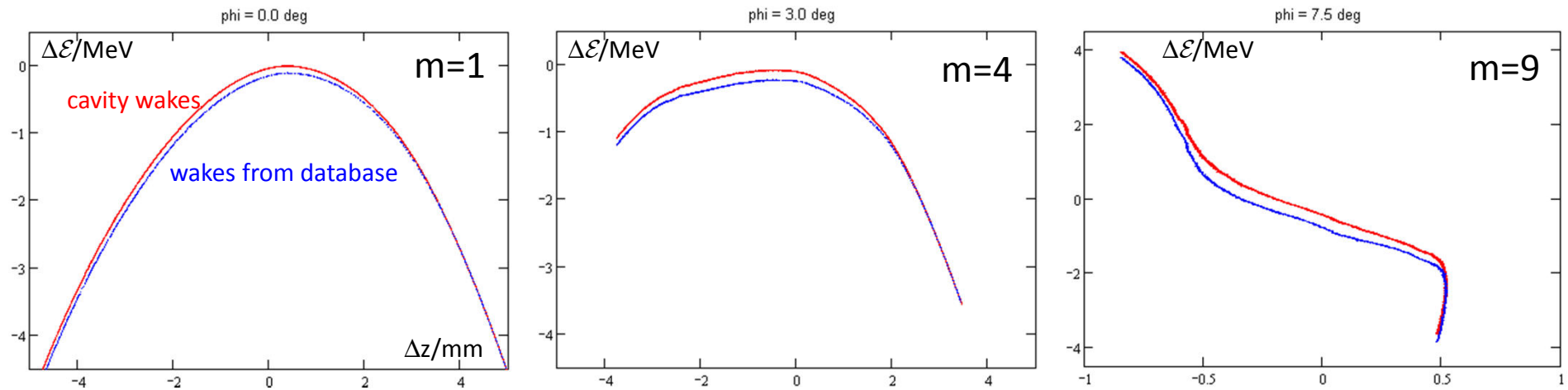

but for the standard compression scenario:



10 Wakes from Database

but for the standard compression scenario:

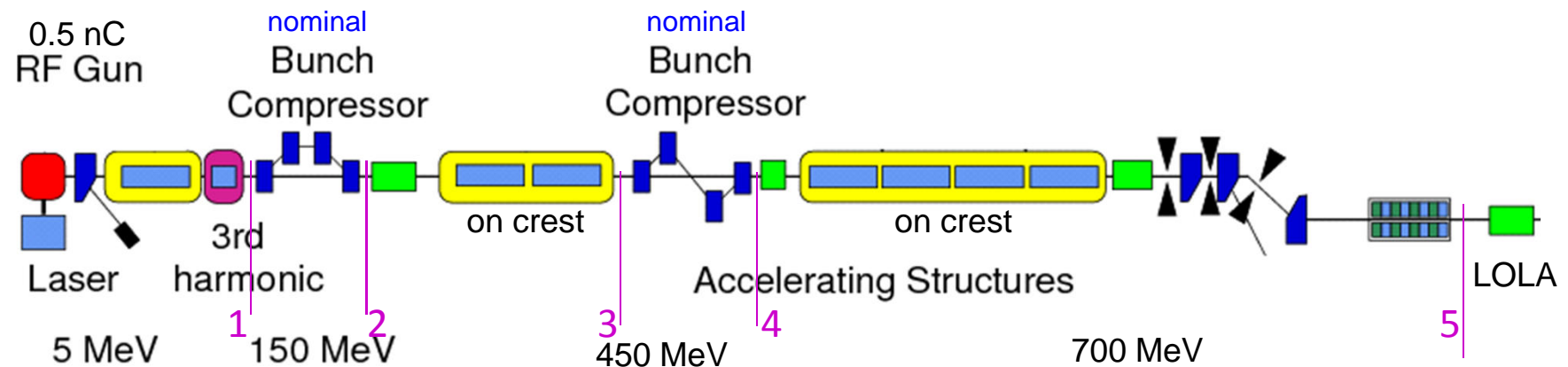

longitudinal density $30A \rightarrow \approx 1.1kA$

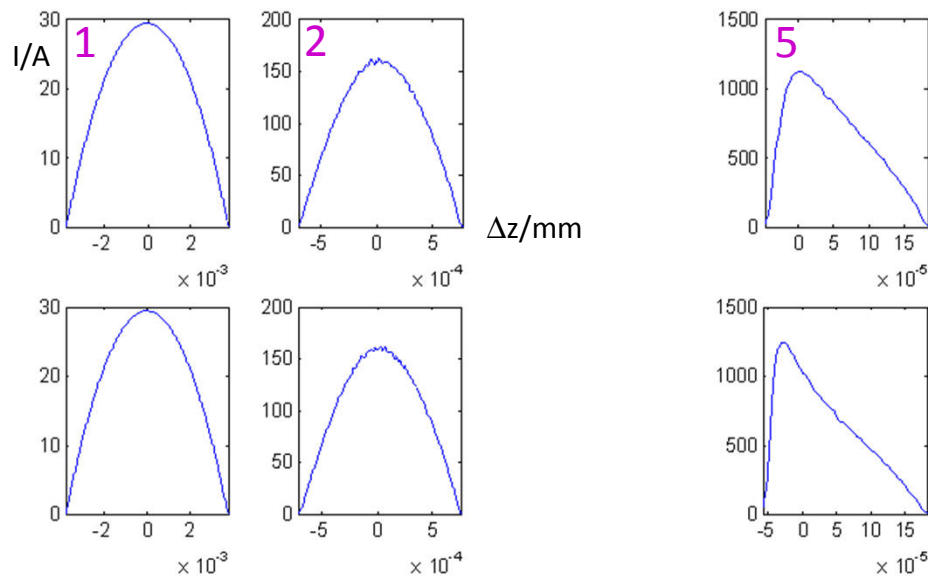

with old wakes (cavity)

with wakes from database



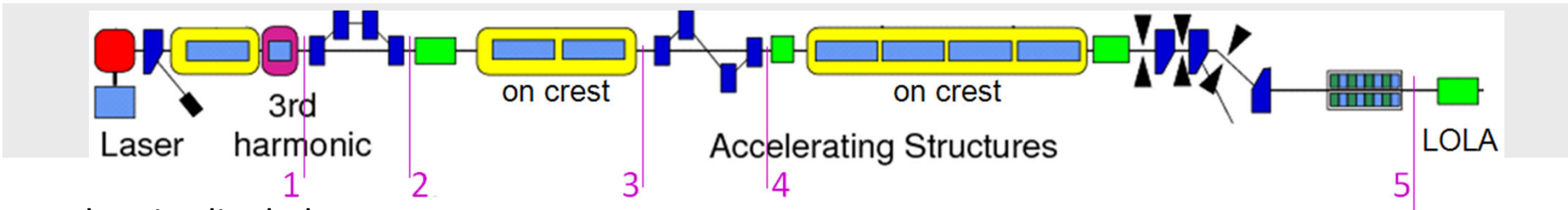

longitudinal phase space

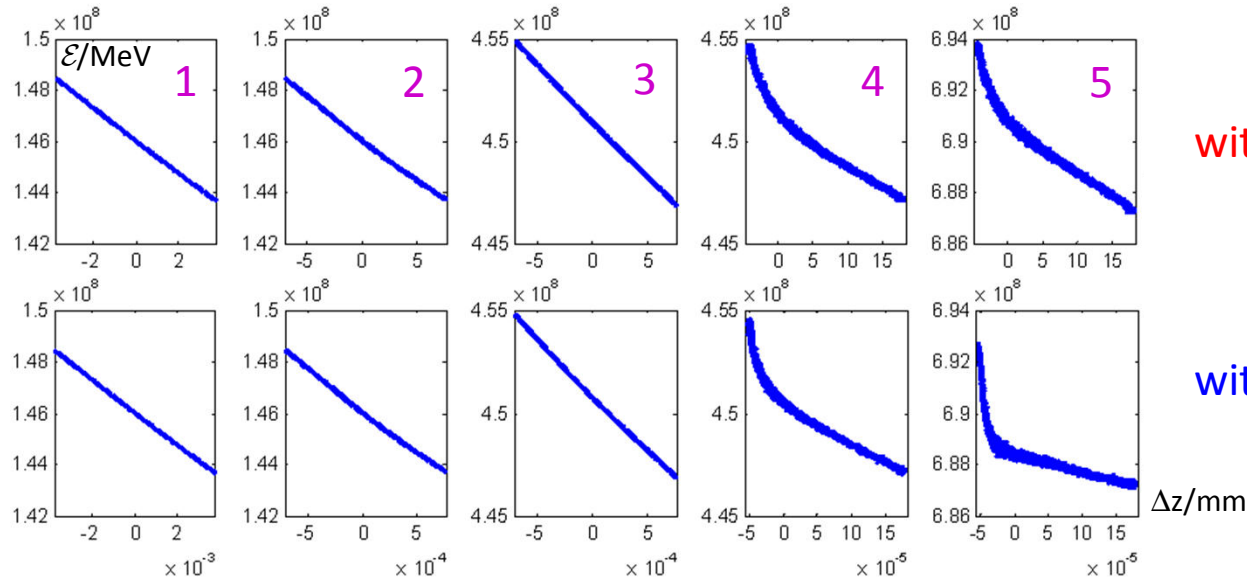

with old wakes (cavity)

with wakes from database

underestimated wake

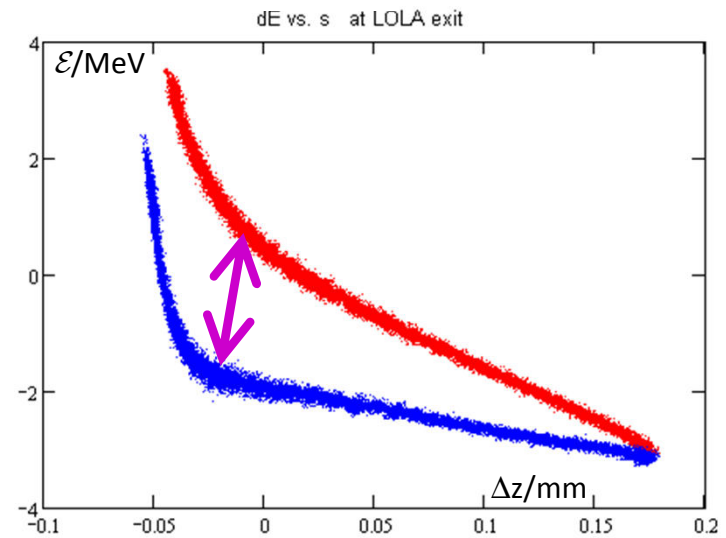

11 LOLA Mystery

f.i. measurements 61&62

zero-crossing #1

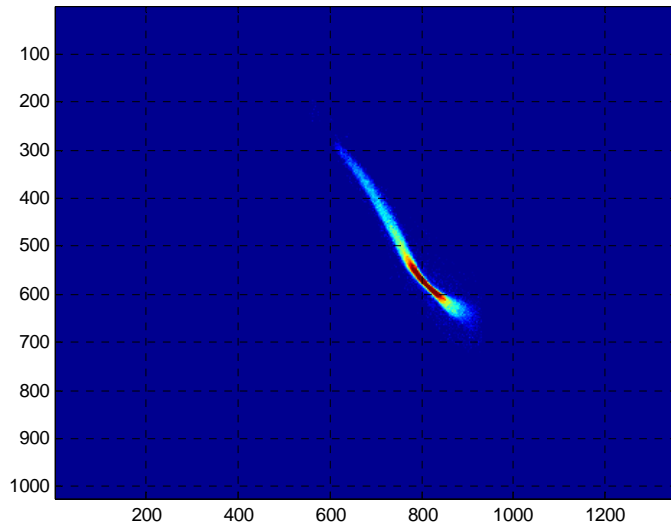

zero-crossing #2, flipped

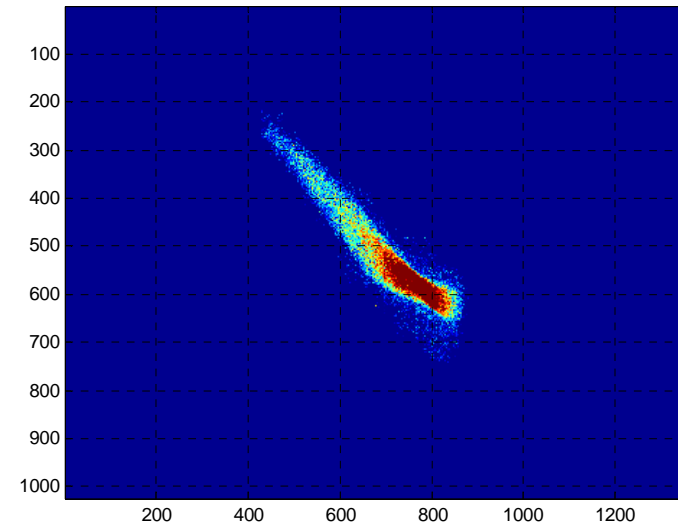

15.4 fsec per pixel

really the same Lola settings?

time	index	rf settings (phases/deg, amplitudes/MV)							
		P1	P2	P3	P4	A1	A2	A3	A4
220515	measurement 61	7.5	-6.6	0	-57.9	164.7	18.1	300.0	253.0
220806	time calibration	-----	???	new LOLA amplitude	-----				
221209	time calibration	-----	???	old LOLA amplitude	-----				
221415	measurement 62	7.5	-6.6	0	-57.9	164.7	18.1	300.0	253.0

perhaps not, but there is more ...



57&58

time		index
213255	measurement	57
213442	measurement	58

rf settings (phases/deg, amplitudes/MV)

P1	P2	P3	P4	A1	A2	A3	A4	index-2
7.5	-6.6	0	-57.9	164.7	18.1	300.0	253.0	110
7.5	-6.6	0	-57.9	164.7	18.1	300.0	253.0	112

no calibration between measurements !!!

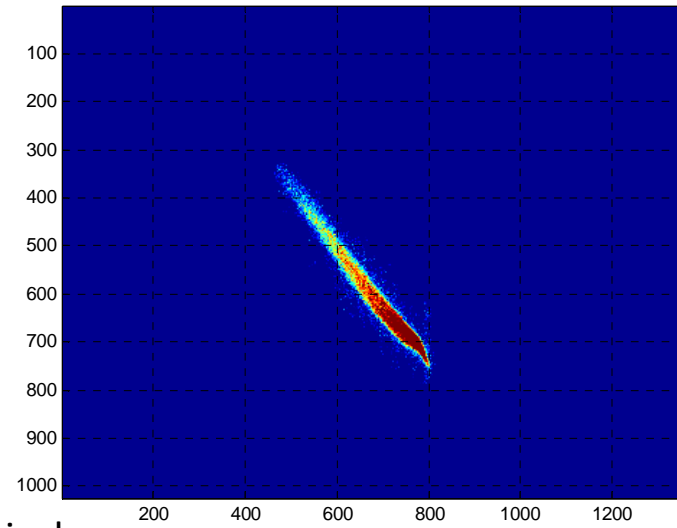
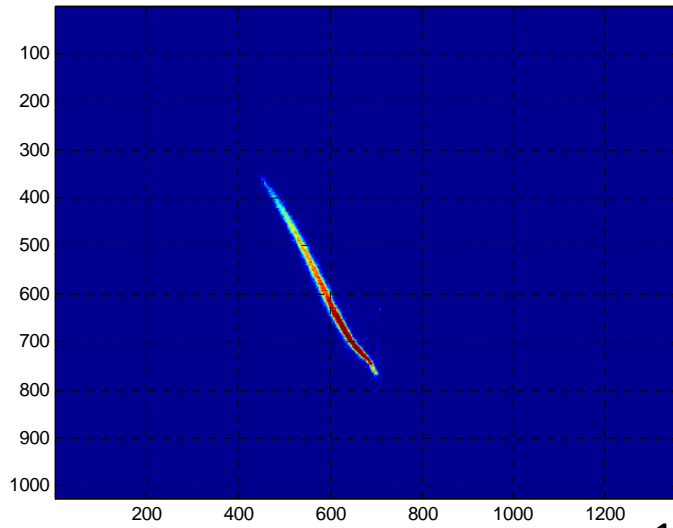

15.4 fsec per pixel

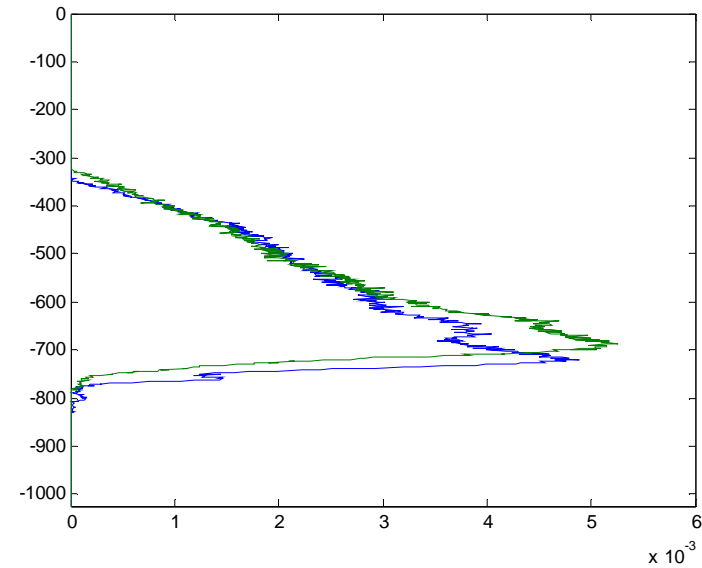
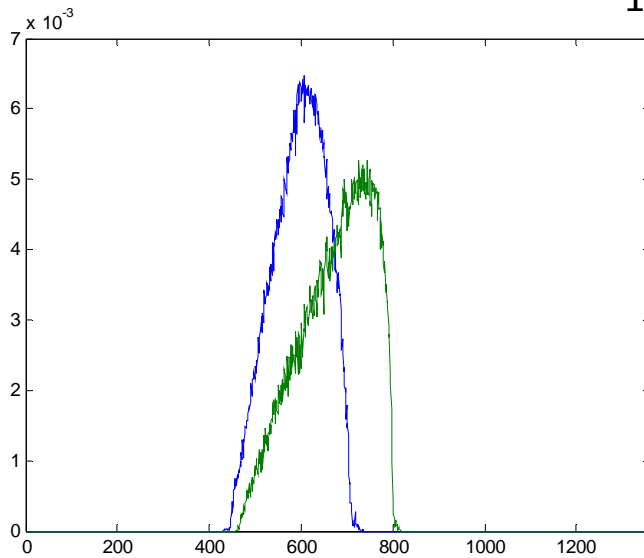

and measurements 1..9



1+&1-

time		index	P1	P2	P3	P4	A1	A2	A3	A4	index-2
210357	measurement	1+	0	0	0	-58	163.3	18	300.0	249.0	3
211751	measurement	1-	0	0	0	-58	163.3	18	300.0	249.0	4

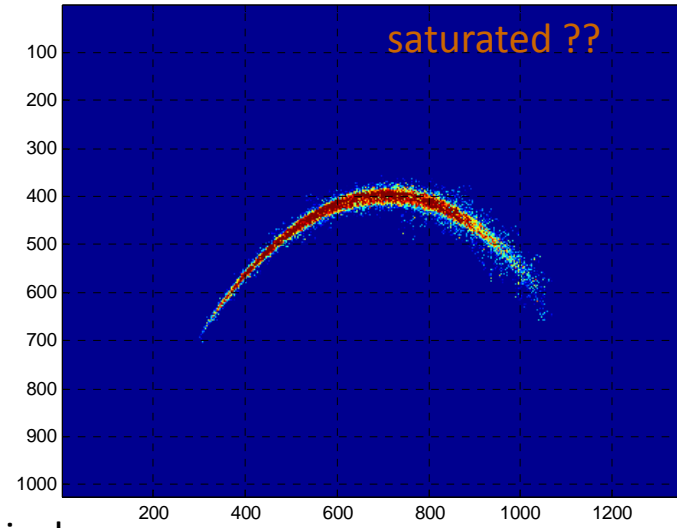
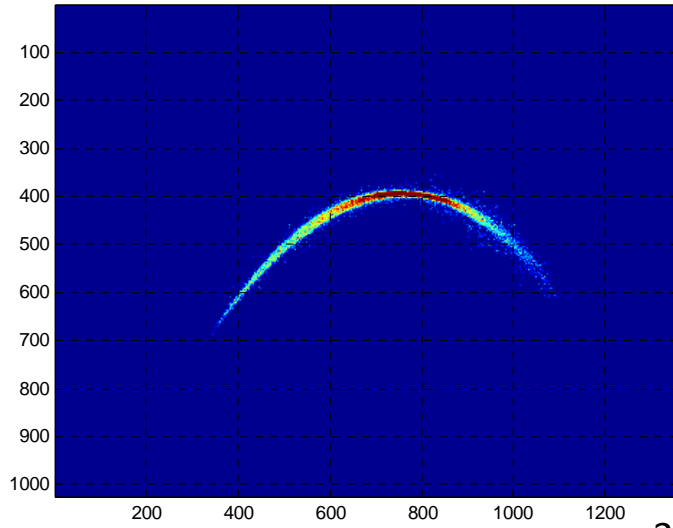

36.3 fsec per pixel

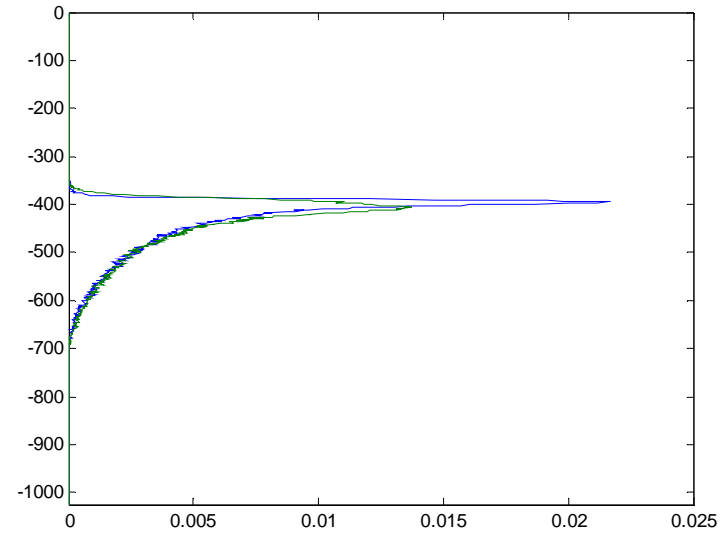
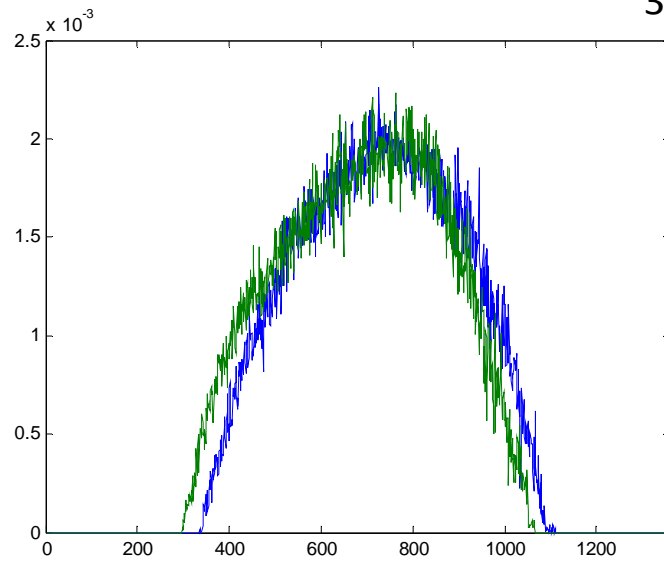

2+&2-

time	index	P1	P2	P3	P4	A1	A2	A3	A4	index-2
212906	measurement 2-	1	-1	0	-58	163.3	18	300.0	249.0	6
213336	time calibration									
213542	measurement 2+	1	-1	0	-58	163.3	18	300.0	249.0	8

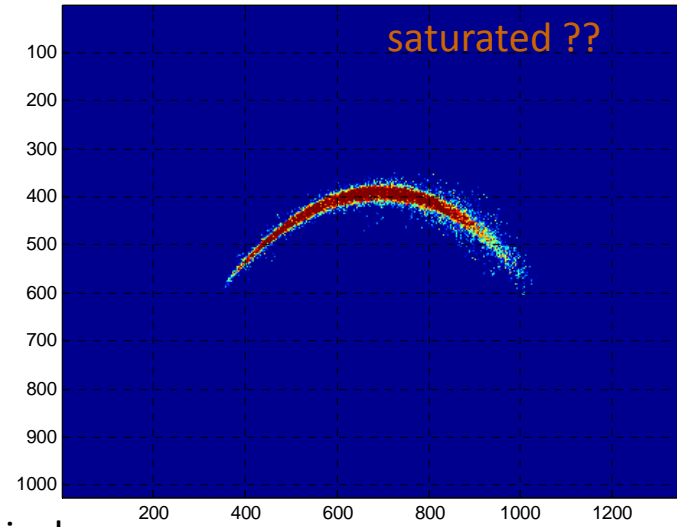
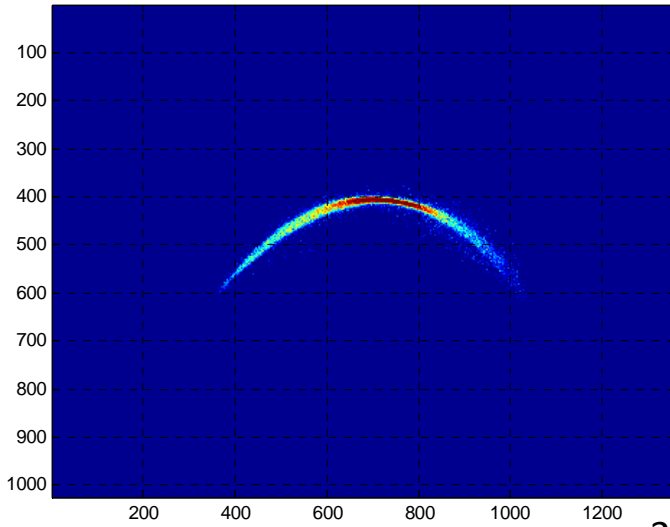

36.3 fsec per pixel

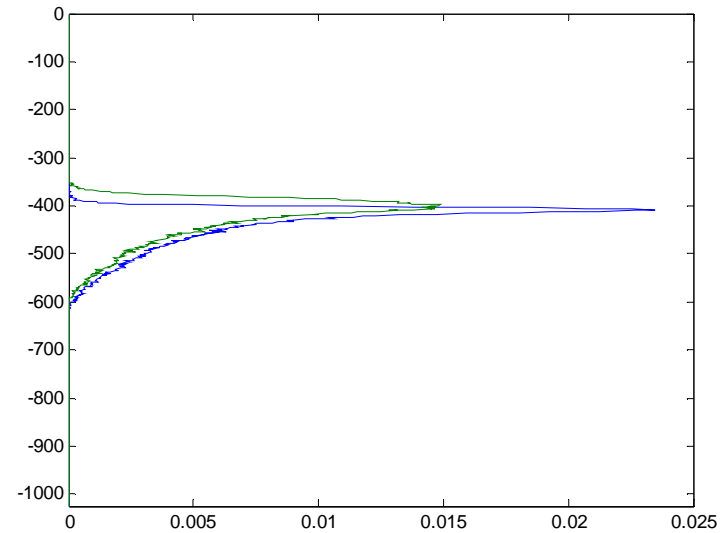
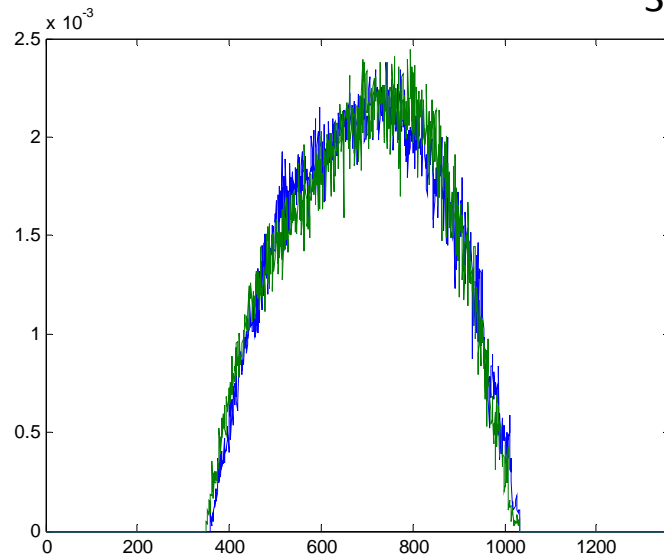

3+&3-

time		index	P1	P2	P3	P4	A1	A2	A3	A4	index-2
214802	measurement	3+	2	-2	0	-58	163.4	18	300.0	249.0	10
215100	measurement	3-	2	-2	0	-58	163.4	18	300.0	249.0	12

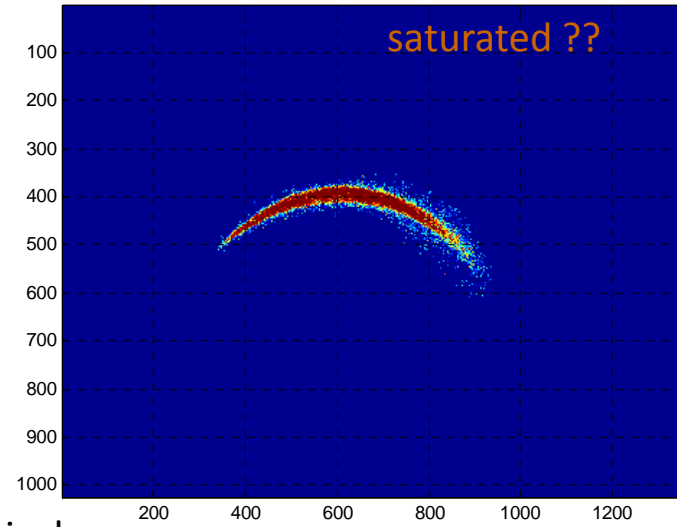
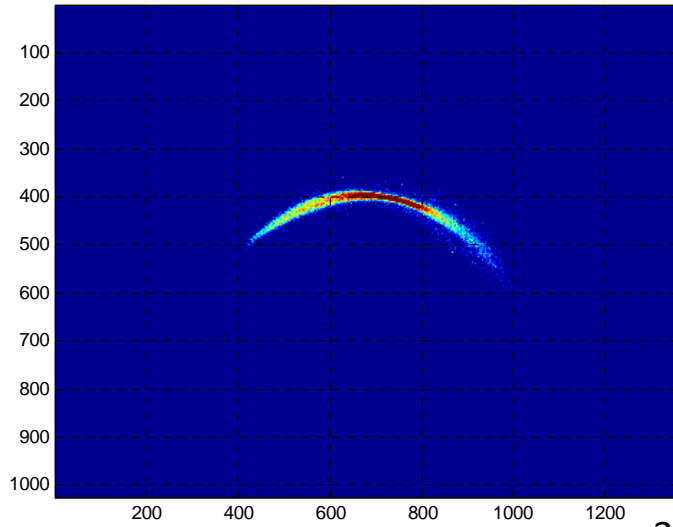

36.3 fsec per pixel

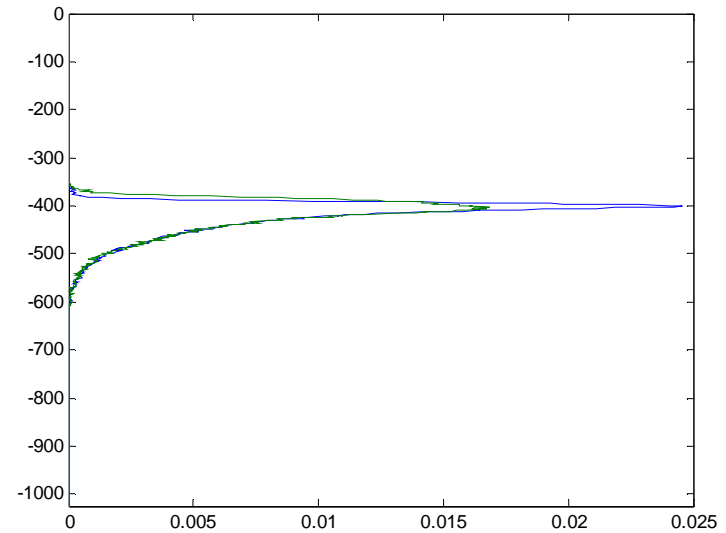
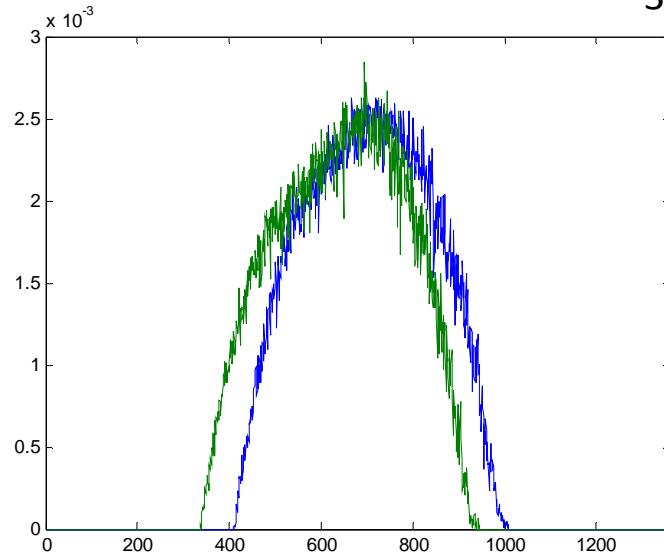

4+&4-

time		index	P1	P2	P3	P4	A1	A2	A3	A4	index-2
215425	measurement	4-	3	-3	0	-58	163.5	18	300.0	249.0	14
215653	measurement	4+	3	-3	0	-58	163.5	18	300.0	249.0	16

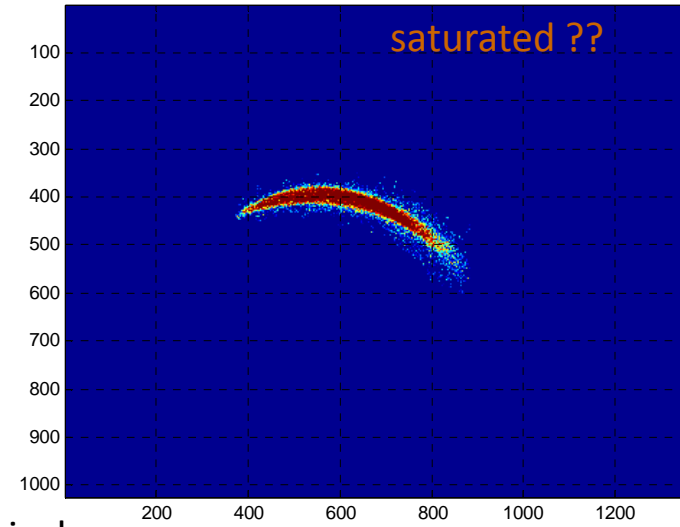
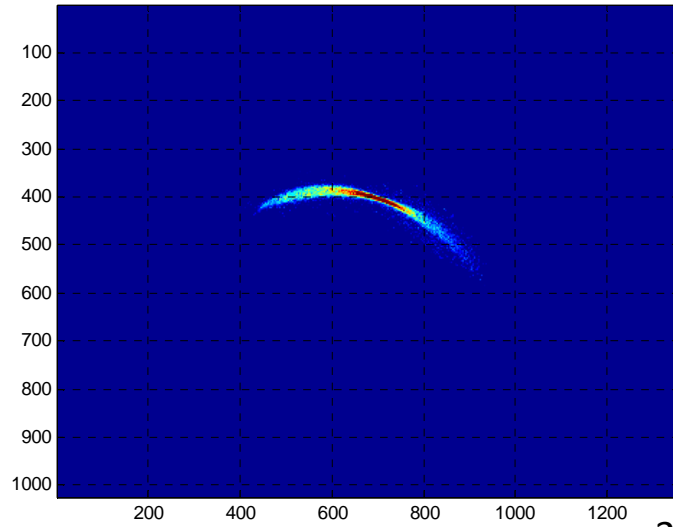

36.3 fsec per pixel

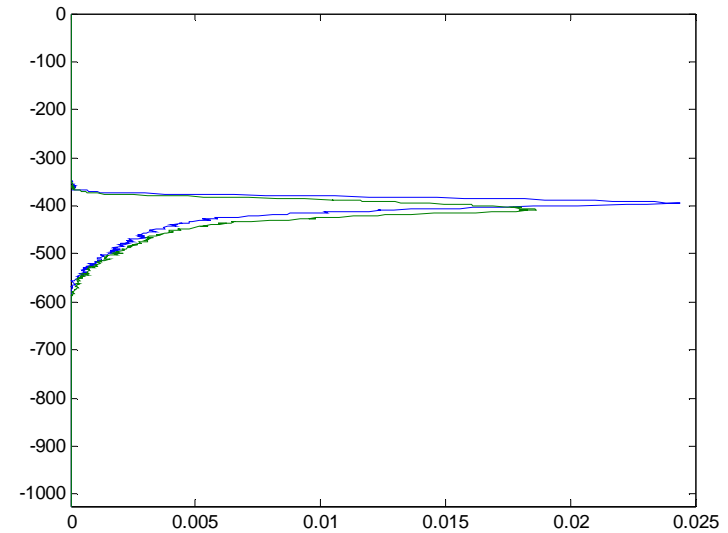
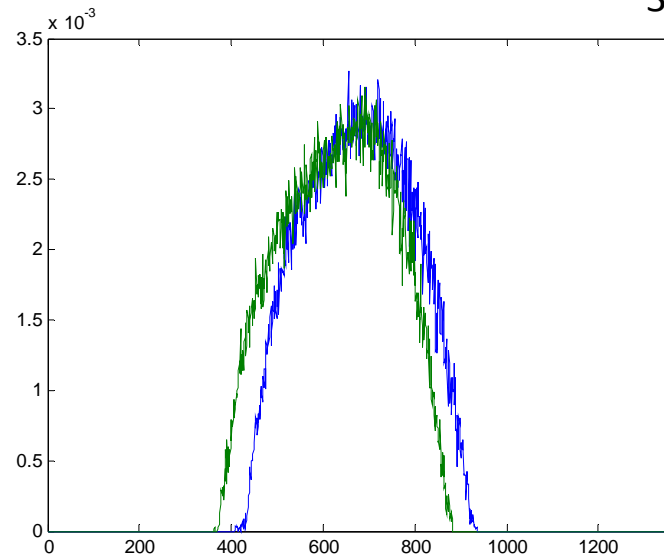

5+&5-

time		index	P1	P2	P3	P4	A1	A2	A3	A4	index-2
220313	measurement	5+	4	-4	0	-58	163.7	18.1	300.0	249.0	18
220513	measurement	5-	4	-4	0	-58	163.7	18.1	300.0	249.0	20

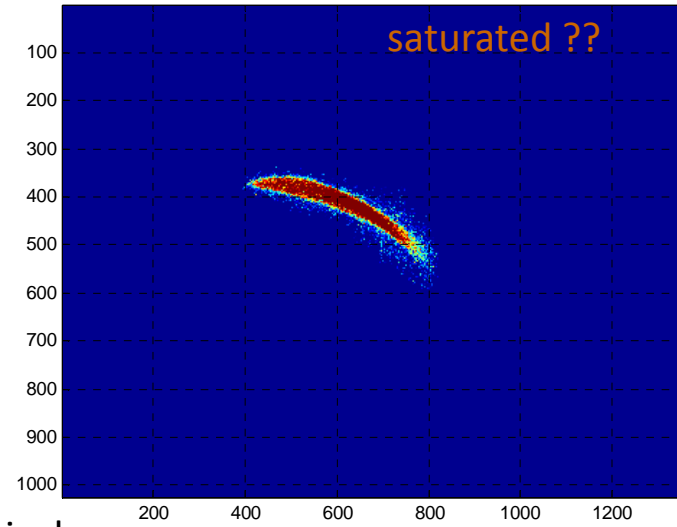
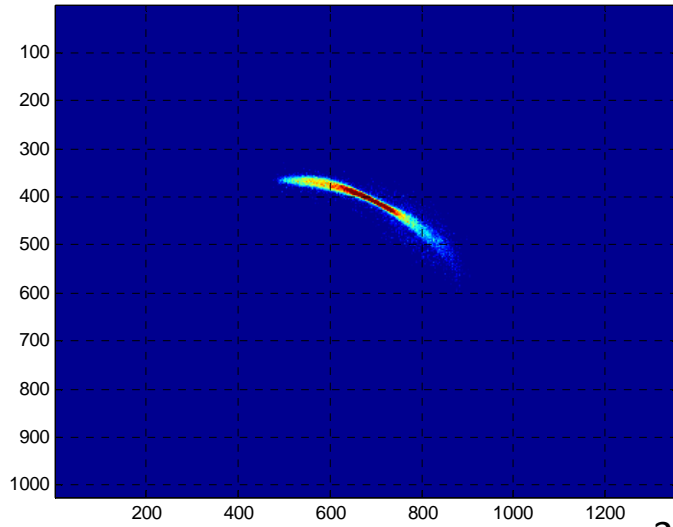

36.3 fsec per pixel

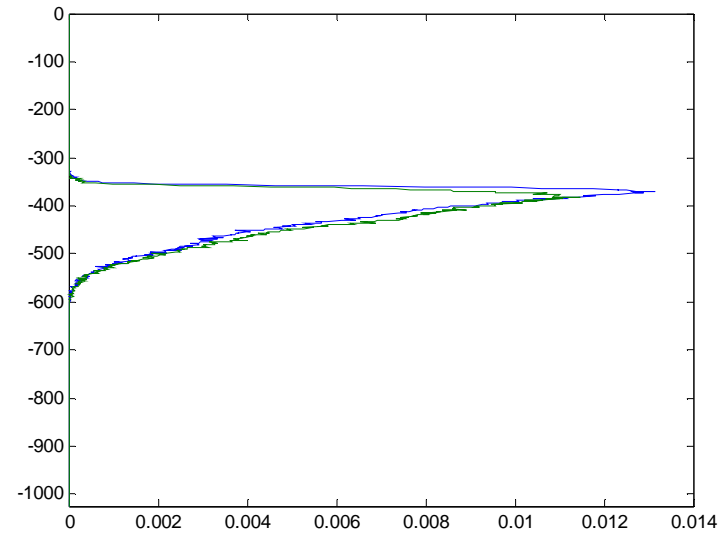
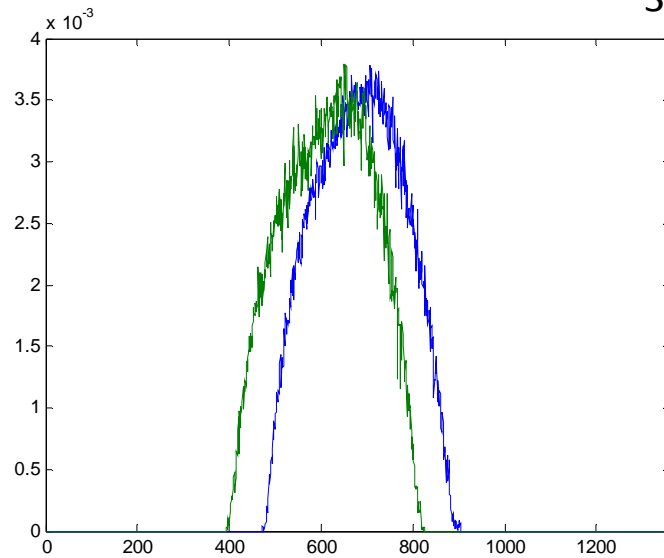

6+&6-

time		index	P1	P2	P3	P4	A1	A2	A3	A4	index-2
221246	measurement	6-	5	-5	0	-58	163.8	18.1	300.0	249.0	22
221729	measurement	6+	5	-5	0	-58	163.8	18.1	300.0	249.0	24

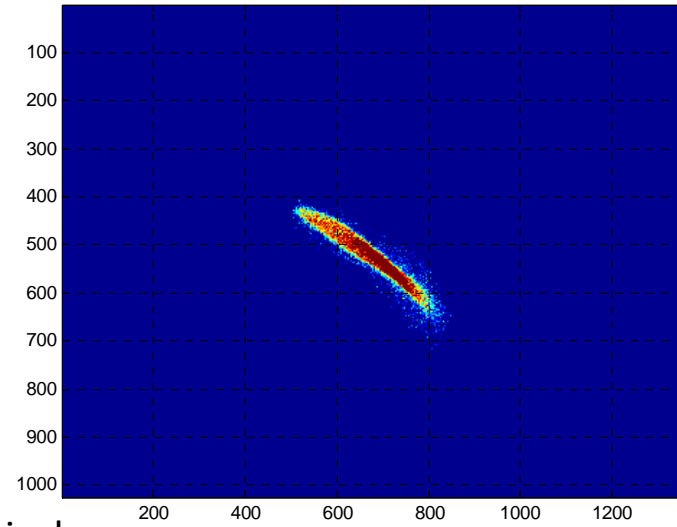
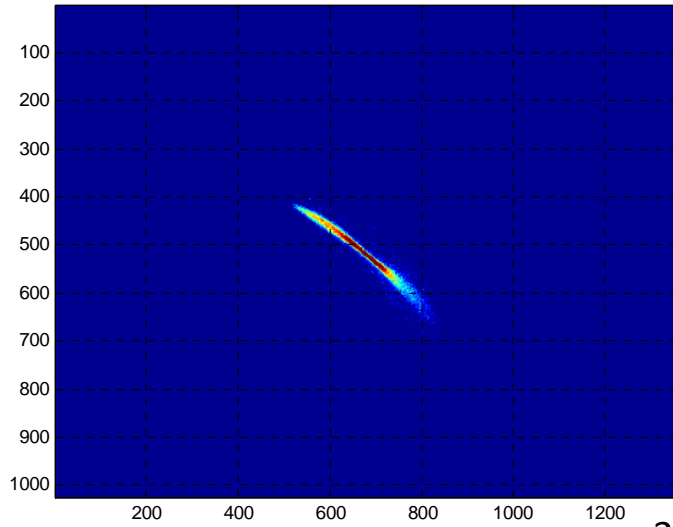

36.3 fsec per pixel

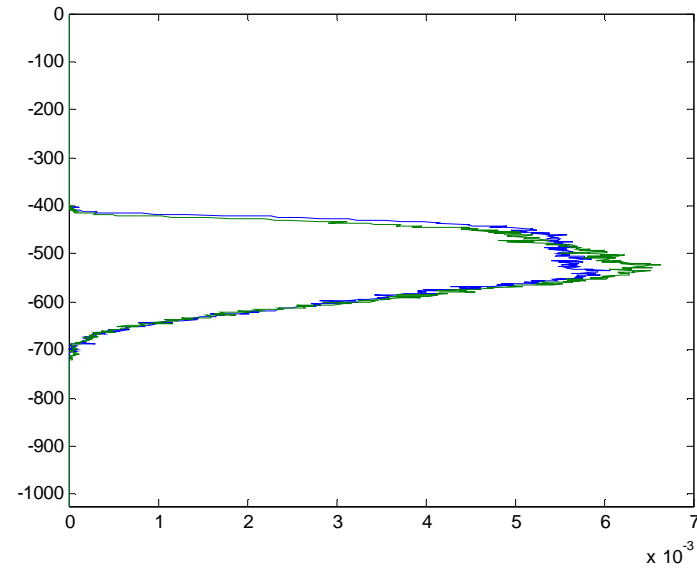
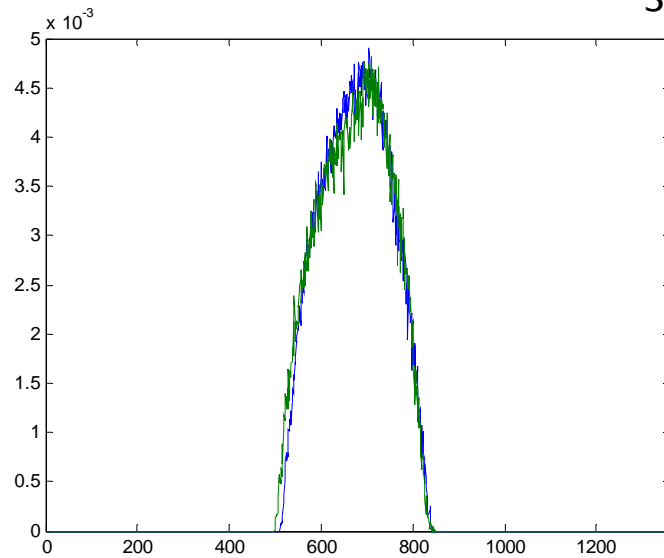

7+&7-

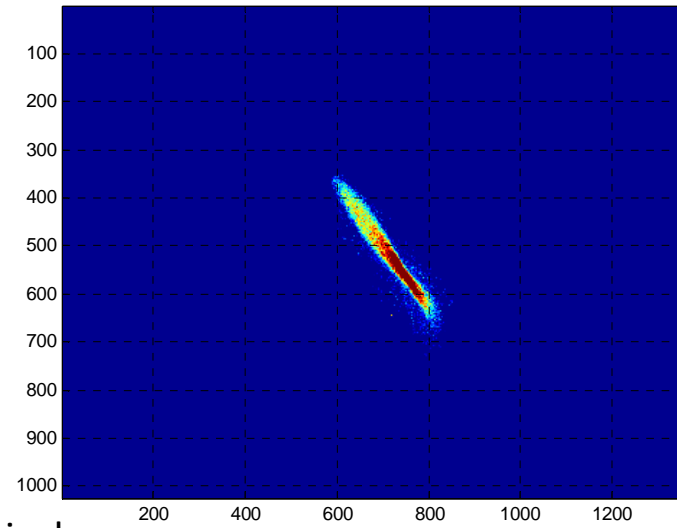
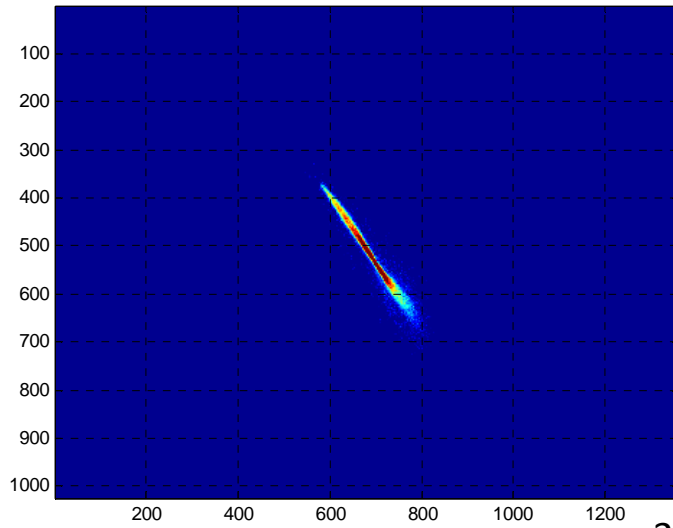

36.3 fsec per pixel

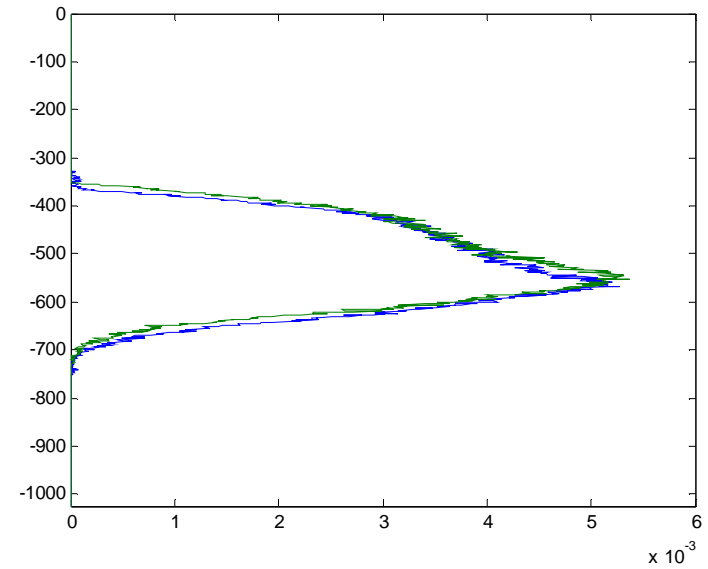
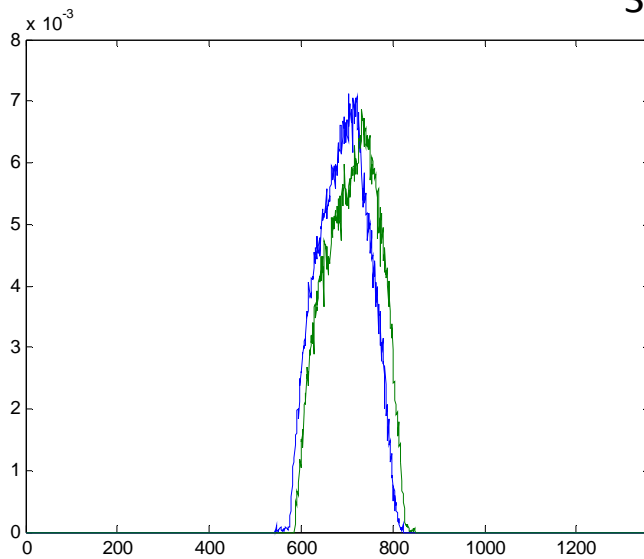

8+&8-

time		index	P1	P2	P3	P4	A1	A2	A3	A4	index-2
222447	measurement	8-	7	-7	0	-58	164.5	18.2	300.0	249.0	30
222624	measurement	8+	7	-7	0	-58	164.5	18.2	300.0	249.0	32

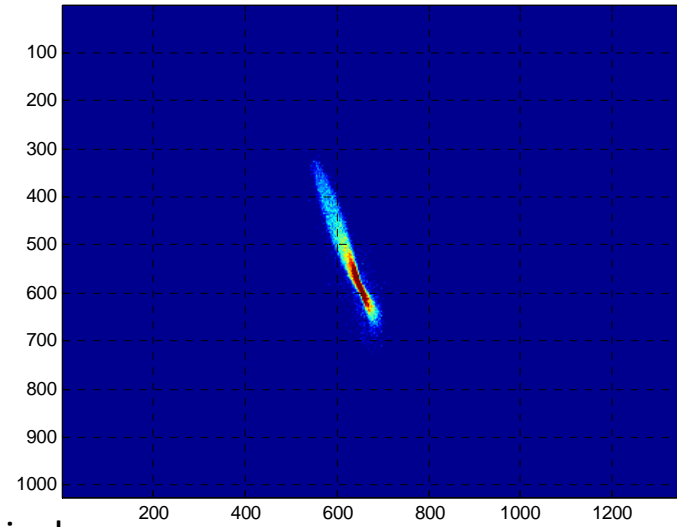
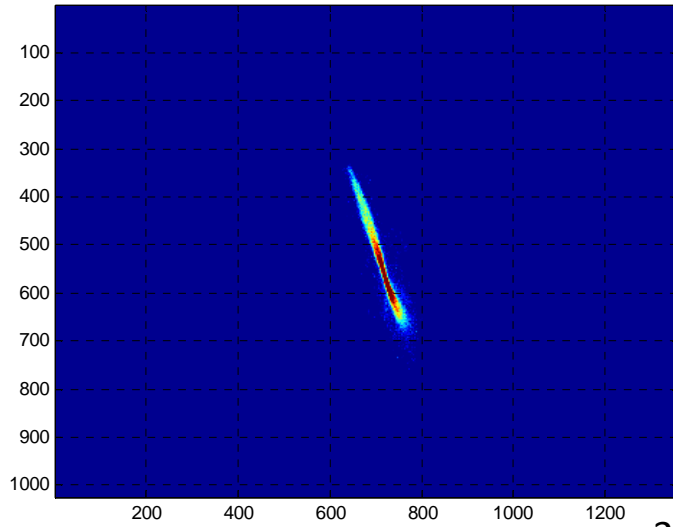

36.3 fsec per pixel

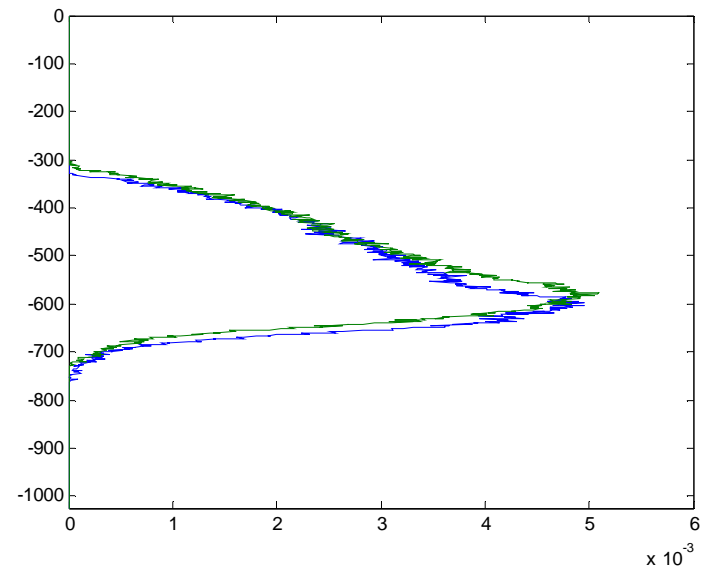
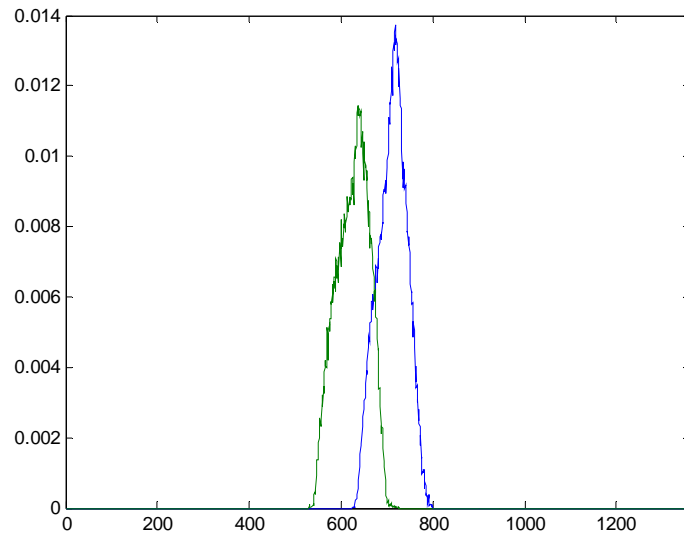

9+&9-

time		index	P1	P2	P3	P4	A1	A2	A3	A4	index-2
222904	measurement	9+	7.5	-7.5	0	-58	164.7	18.2	300.0	249.0	34
223058	measurement	9-	7.5	-7.5	0	-58	164.7	18.2	300.0	249.0	36

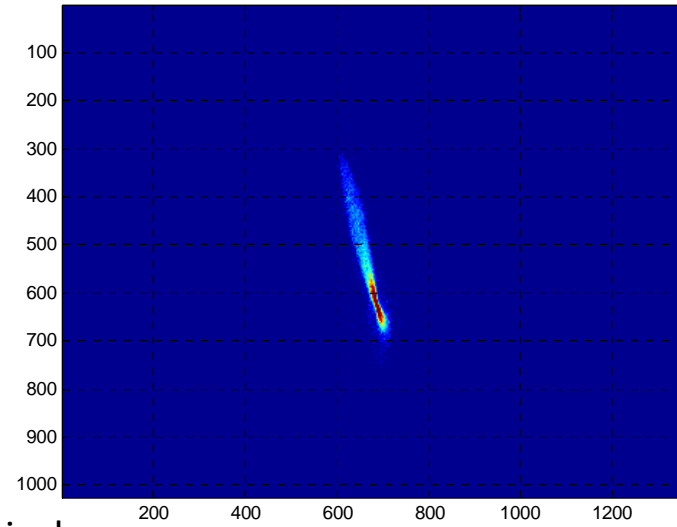
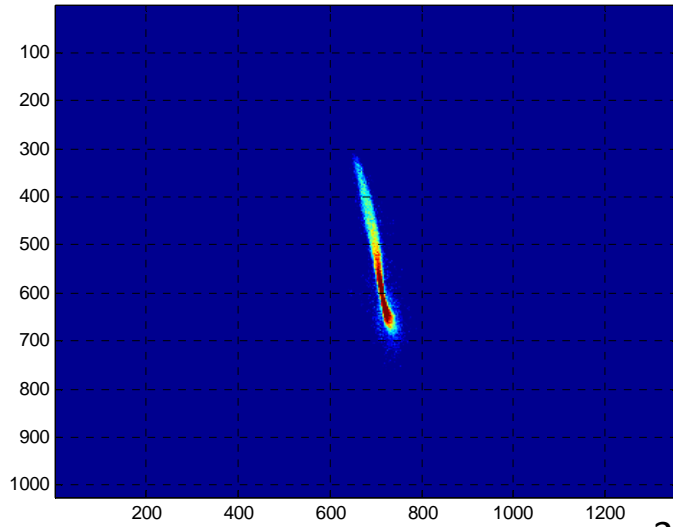

36.3 fsec per pixel

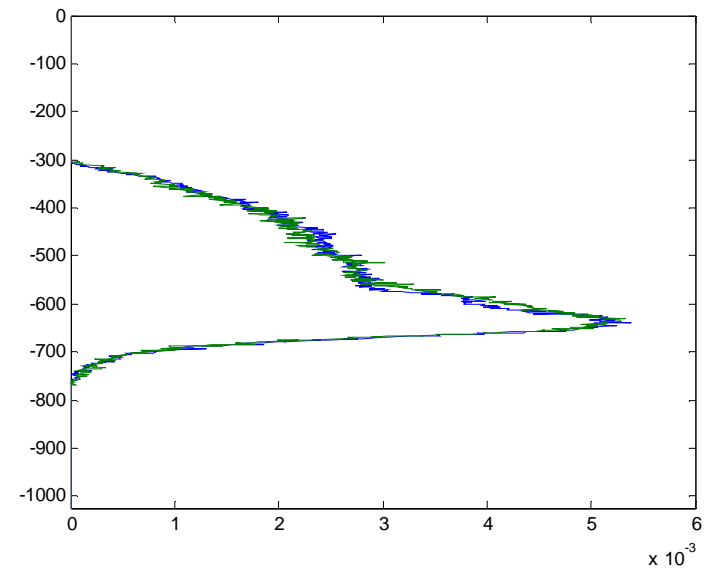
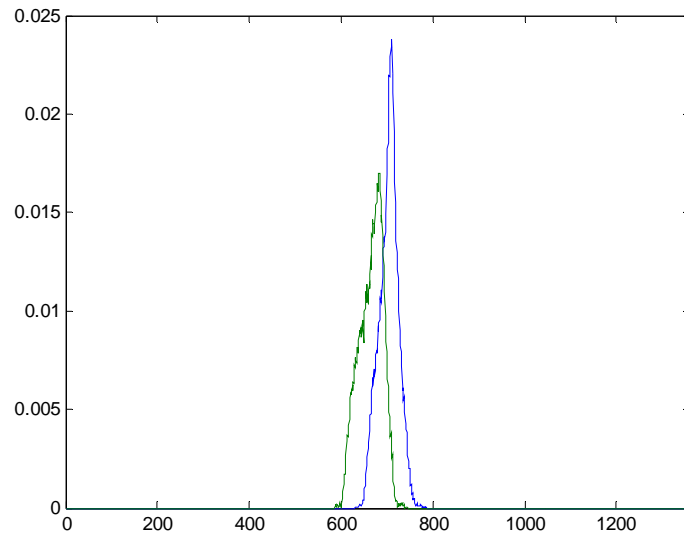

11 LOLA Mystery

Lola imaging matrix for 15.4 fsec/pixel:

$$P = 5.3 \times 10^5$$

$$Ene = 7 \times 10^8$$

desired effect

$$\begin{array}{l}
 \text{"time" axis} \\
 \text{"energy" axis}
 \end{array}
 \begin{pmatrix}
 1 & 0 & 0 & 0 & 0 & 0 \\
 0 & 0 & 1 & 0 & 0 & 0
 \end{pmatrix}
 \cdot T(Vy, Ene) = \begin{pmatrix}
 1 & 12.686 & 0.332 & 0.636 & 0.081 & 0.872 \\
 0 & 0 & 0.831 & 11.388 & 3.734 & 0
 \end{pmatrix}$$

$$\begin{pmatrix}
 1 & 0 & 0 & 0 & 0 & 0 \\
 0 & 0 & -1 & 0 & 0 & 0
 \end{pmatrix}
 \cdot T(-Vy, Ene) = \begin{pmatrix}
 1 & 12.686 & -0.332 & -0.636 & 0.081 & 0.872 \\
 0 & 0 & -0.831 & -11.388 & 3.734 & 0
 \end{pmatrix}$$

$$\begin{pmatrix}
 x \\
 x' \\
 y \\
 y' \\
 s \\
 \delta
 \end{pmatrix}$$

focusing does not change with sign of streak
 uncorrelated hor/vert/long should produce the same picture
 is there correlation ???

"smearing" on "energy" axis?:

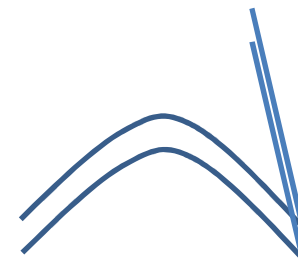
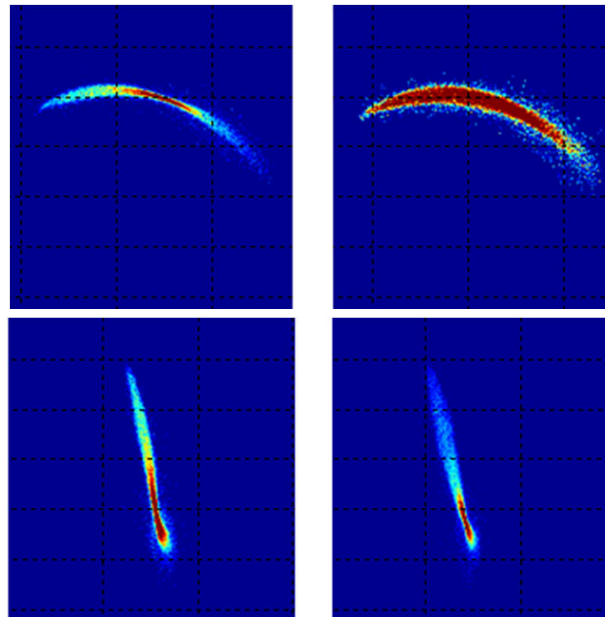

12 Summary

new measurements close to measurements from 2011; BC3 off!
slightly lower charge; no spike at head (as in 2011);
analysis for measurements (1-9) with same calibration;

tt-reconstruction (only projected distributions): averaging of multiple measurements and LOLA phases, but no smoothing; consistent results for week compression; two- and multi-point reconstruction
→ cannot be distinguished: initial chirp or different r56 of BC2
2012 distribution is slightly shorter
qualitative agreement of longitudinal phase space (for week compr.)

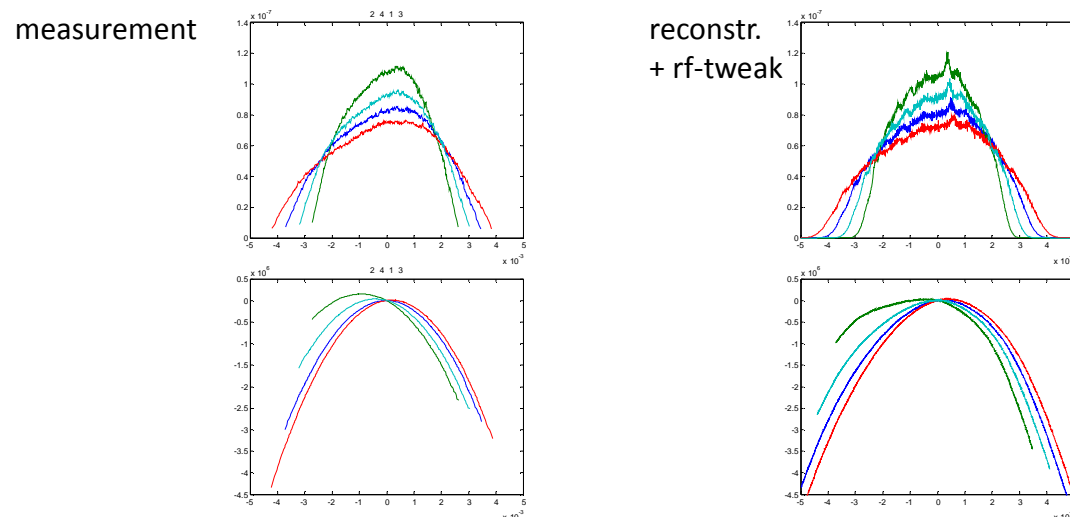

12 Summary

wakes from database: cavities contribute only to a fraction of the total wake; wrong slope in old energy measurement in comparison to rf-tweak reconstruction is (probably) caused by two effects:
 (i) LOLA crosstalk; (ii) missing impedance

gaussian bunch, $\sigma = 170 \mu\text{m}$
 wake of cavities in ACC2 .. ACC7
 wake after BC2

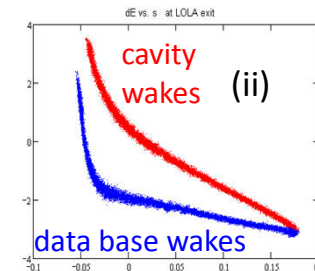
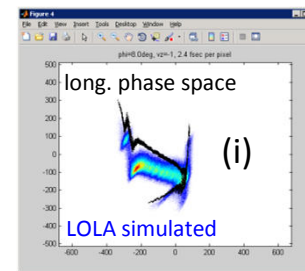
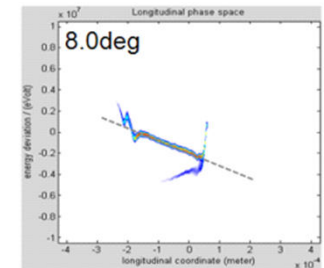
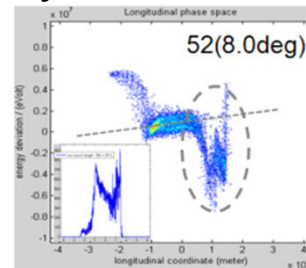
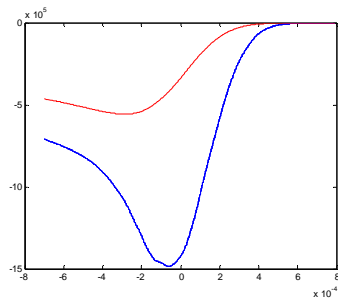

LOLA mysteries: needs more work

