

Update on the Beam-Related Backgrounds in the LDC Detector

Exploring the Parameter Space

Adrian Vogel
DESY FLC

Background Sources at the ILC

e^+e^- pairs are a main source of background

- beams have to be focused very strongly ($\sigma_y = 5 \text{ nm}$)
- beam-beam interaction creates beamstrahlung
- beamstrahlung photons scatter to e^+e^- ($10^5 / \text{BX}$)
- e^+e^- smash into forward calorimeters (BeamCal) and magnets of the beam delivery / extraction line
- lots of photons, neutrons, and charged particles

Other sources are supposed to be negligible (beam dump, synchrotron radiation, ...) or have to be studied in further detail (beam halo, extraction line losses)

Problems with Background

Inner silicon trackers (VXD, SIT, FTD)

- hits from charged particles (direct / indirect)
- silicon bulk damage from neutron fluence

Main gaseous tracker (TPC)

- Compton scattering, photon conversion
- neutron-proton collisions (recoil) with hydrogen
- additional primary ionisation, field distortions

Calorimeters (ECAL, HCAL)

- more photons from nuclear reactions, neutron capture
- random low-energy hits, radiation damage (?)

Simulation Tools – Guinea Pig

Input

- set of beam parameters ($E, \vec{\sigma}, \vec{\beta}, Q, \dots$)

Output

- particles in the disrupted beams
- beamstrahlung photons
- e^+e^- pair particles
- hadronic scattering products (“minijets”)

Existing simulation data

- TESLA beam parameters (500 GeV, 800 GeV)
- various ILC parameter sets (500 GeV, 1 TeV)

ILC Beam Parameters

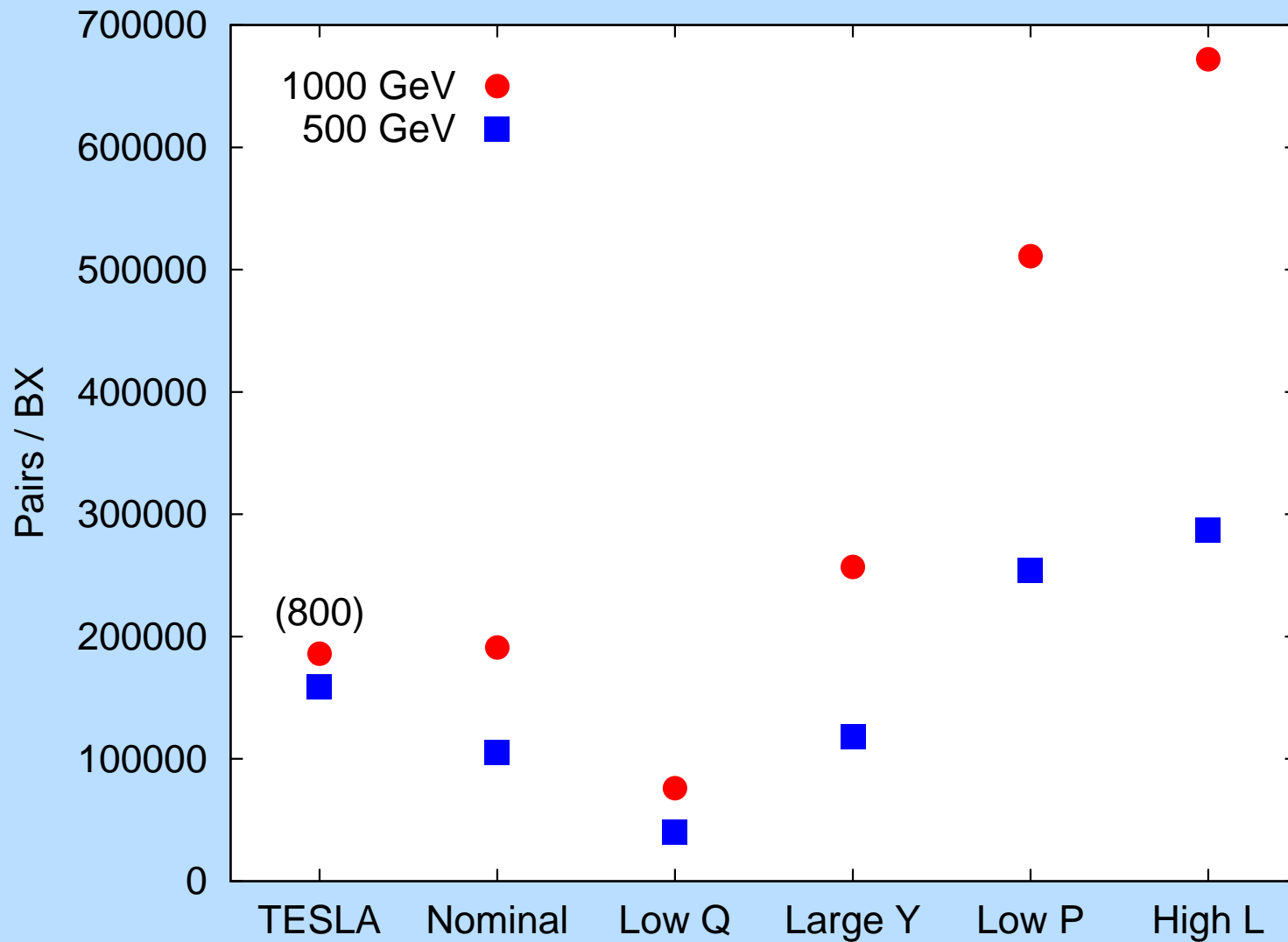

S. Gronenborn (EUROTeV-Memo-2005-003-1)

Simulation Tools – Mokka

Mokka is a full detector simulation

- based on the Geant 4 framework (currently 8.1.p01)
- written in C++, contains various detector geometries
- main development at LLR, France
- now: contributions from many different users
- successor of Brahms (GEANT3, Fortran)

Mokka uses LCIO as a persistency framework

- predefined storage classes (particle, track, hit, ...)
- lightweight and robust, cross-platform design
- supported by large parts of the ILC community

“Small” LDC Detector Design

- Coil and TPC have been shortened
- ECAL and LumiCal have been pulled towards the IP
- FF at $L^* = 4.05$ m remains unchanged
- BeamCal stays where it was
- New layout of the forward region

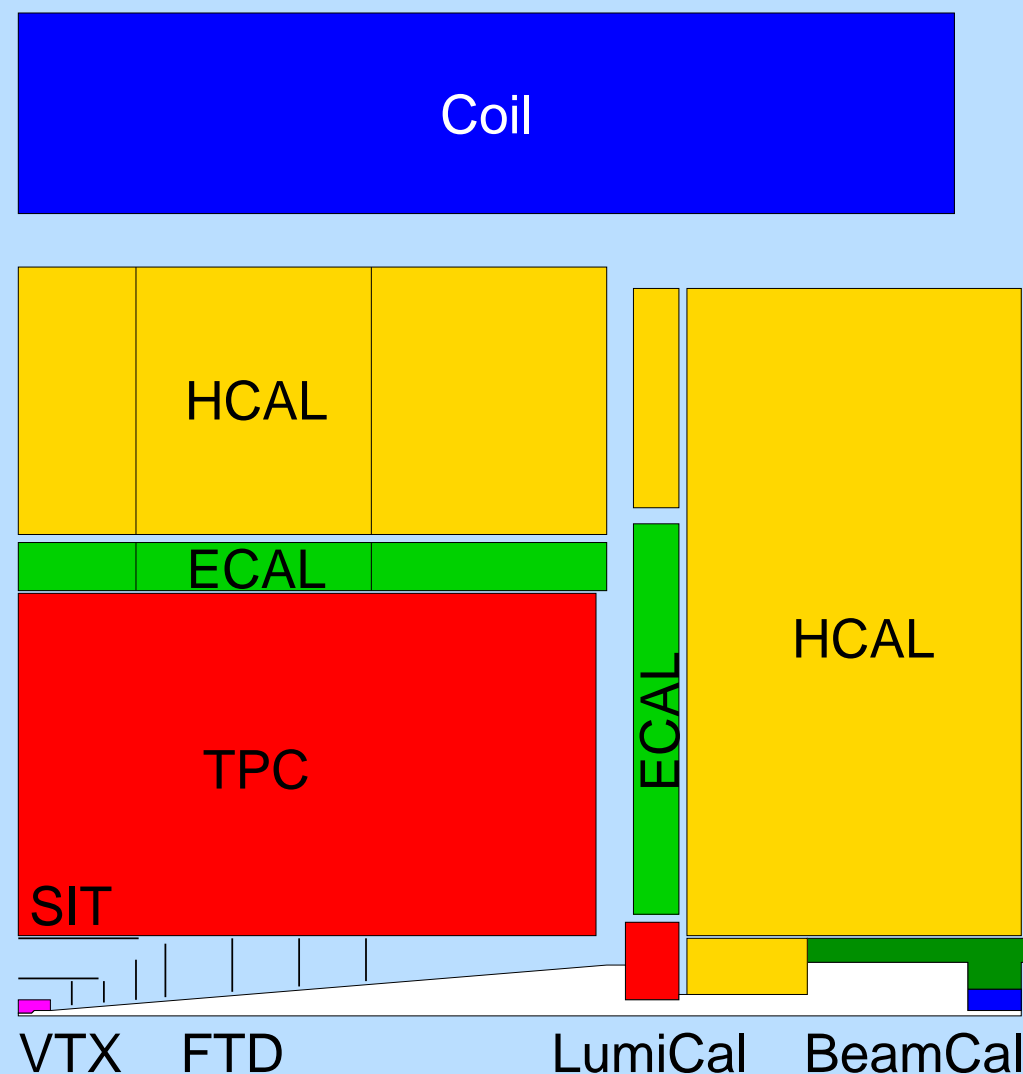

LDC Detector Geometry

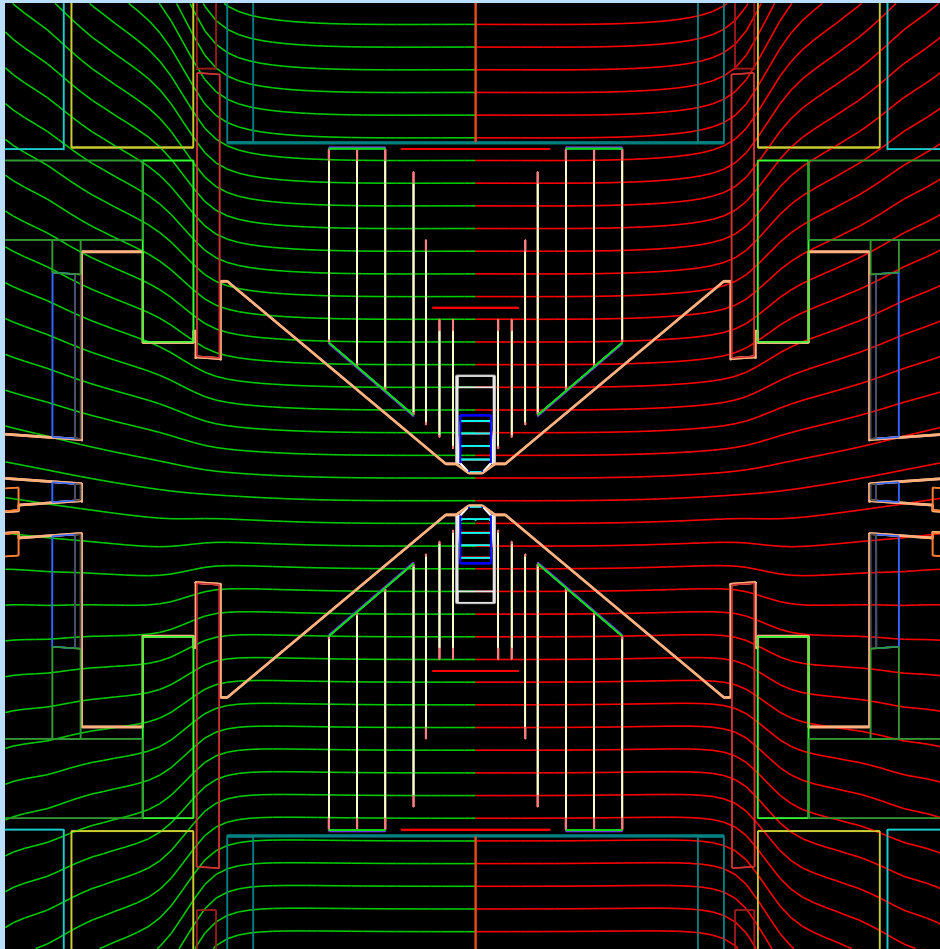

14 mrad crossing angle
with anti-DID field (1:10)

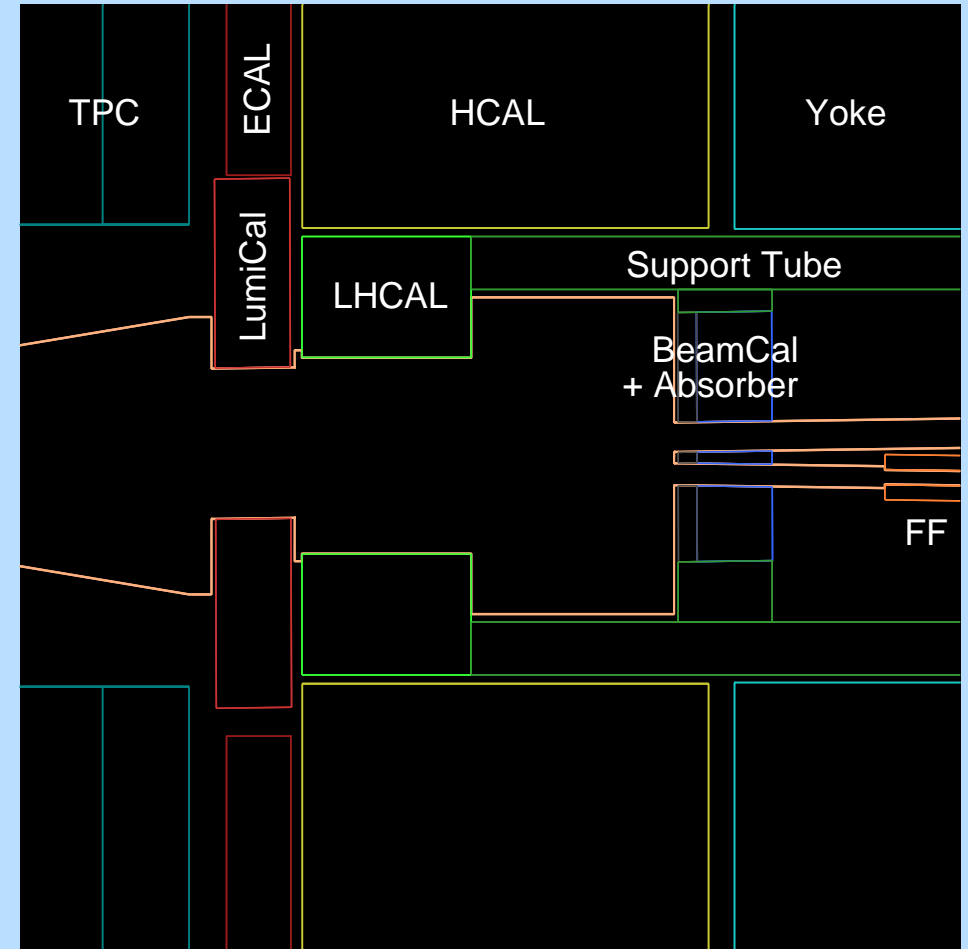

Forward region design
(compressed view 1:2)

Computing

Simulations need a lot of computing time

- $\mathcal{O}(10^5)$ particles per BX, many create EM showers
- full simulation is required: looking for “rare” incidences
- run time is 12 h to 48 h per BX (depending on settings)

Jobs are run on the Grid

- more than 20 computing centres support the ILC
- over 8000 CPUs are available (shared with other VOs)
- data for this talk was produced in HH, Zeuthen, Lyon
- 100 BX can easily be processed in a single day

The Grid also provides mass storage for simulated data

VTX Hits – Geometries

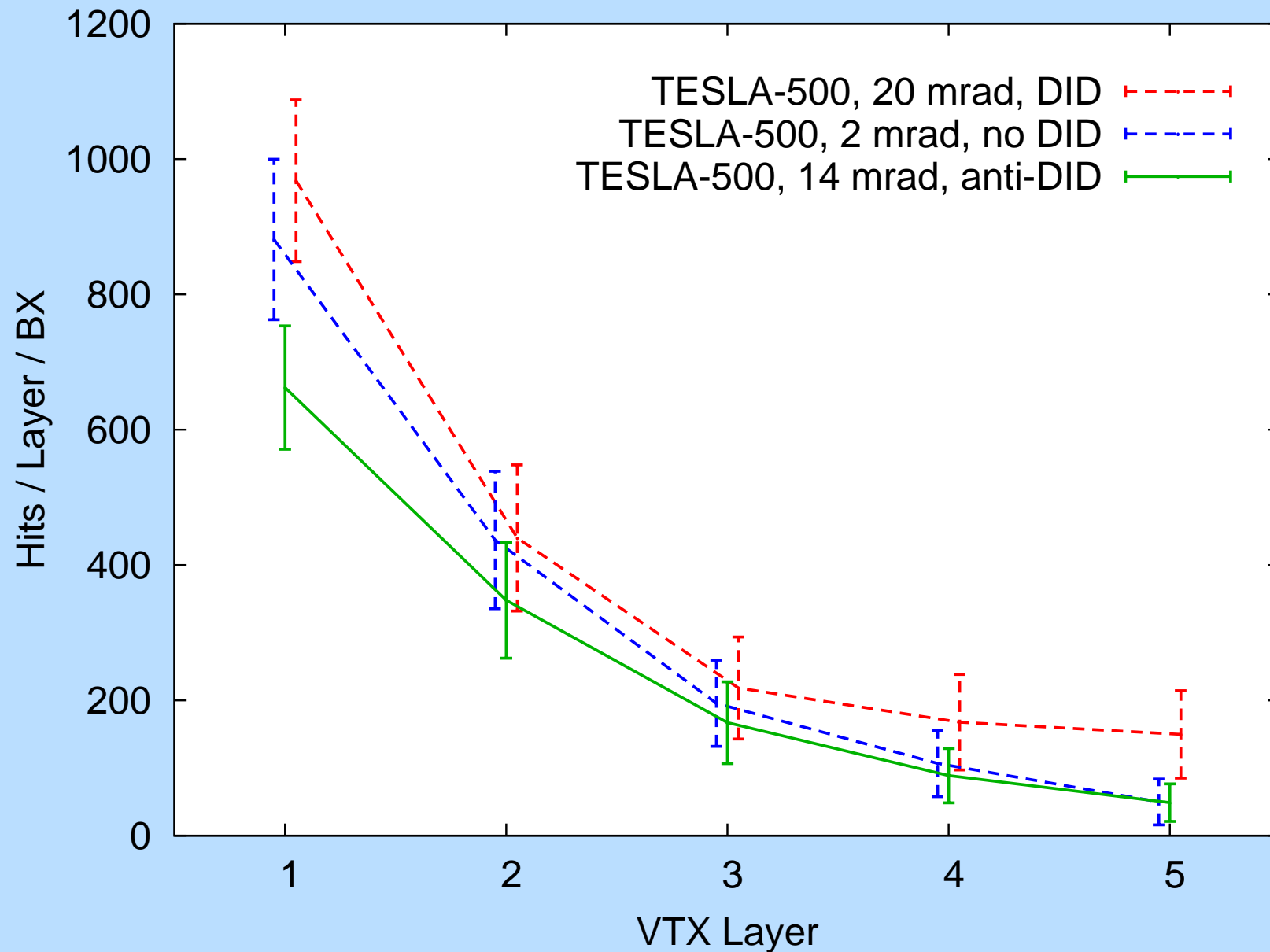

VTX Hits – Beam Parameters

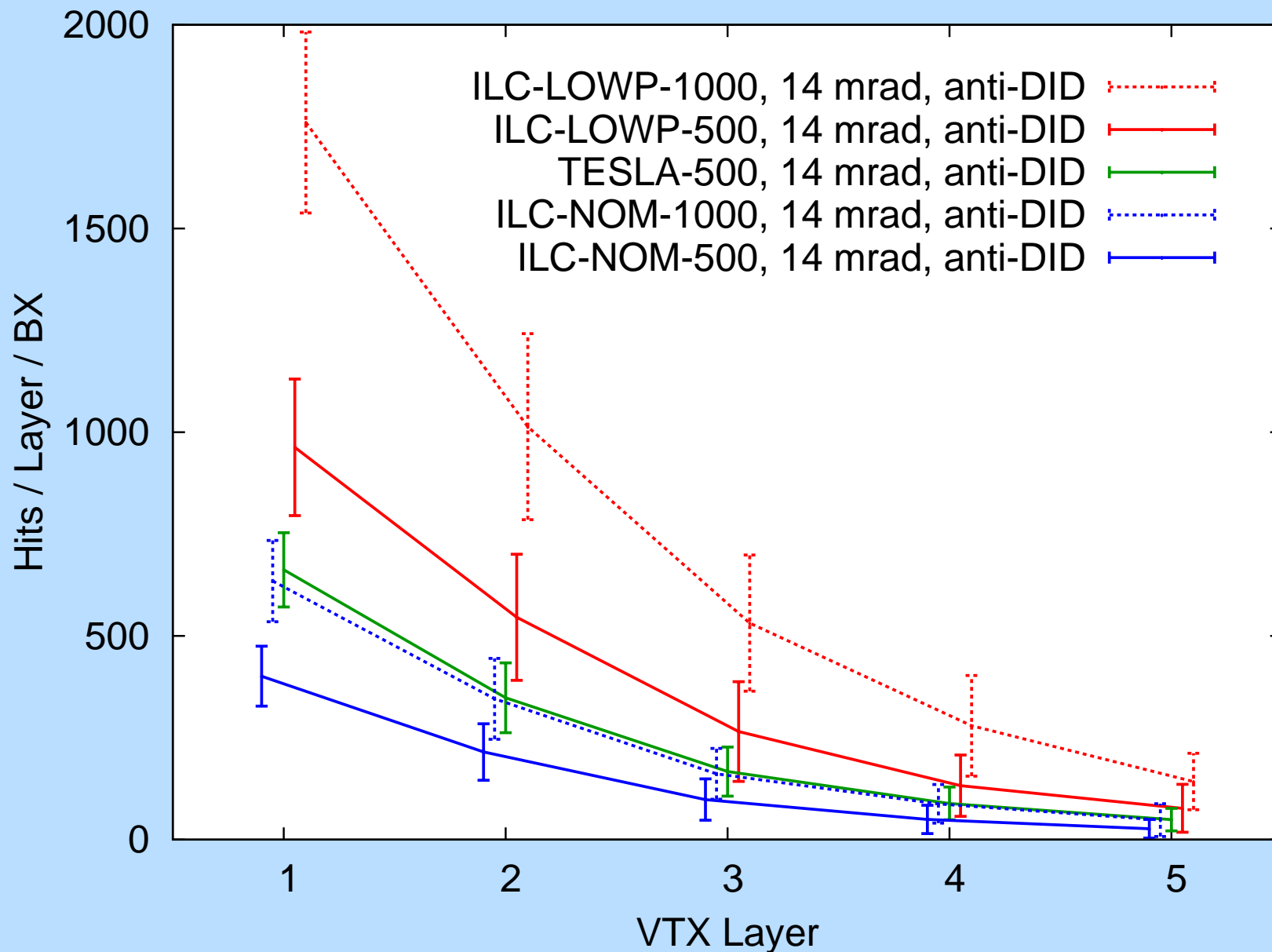

Backscattering Sources

- Many backscatterers come from the BeamCal
- Low-Z absorber suppresses that
- But: too much material will disturb the BeamCal
- How thick should the absorber be?
- Can a cladding of the inner surface help?

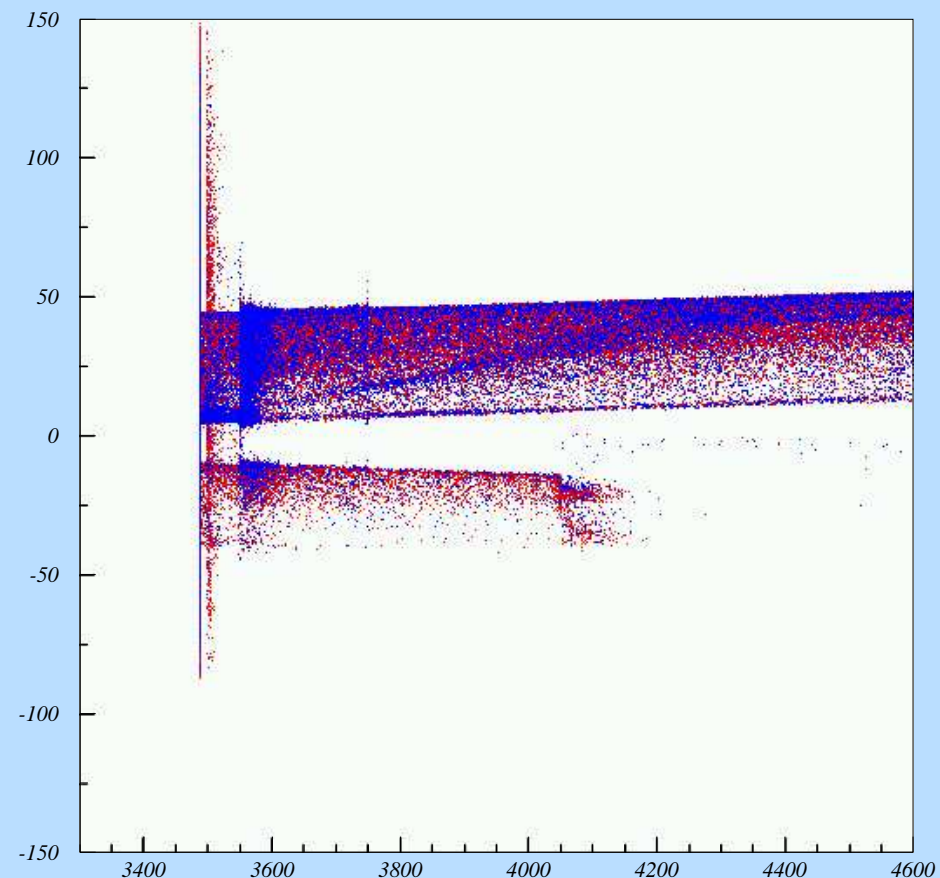

Origins of backscattered electrons and positrons

VTX Hits – Low-Z Absorber

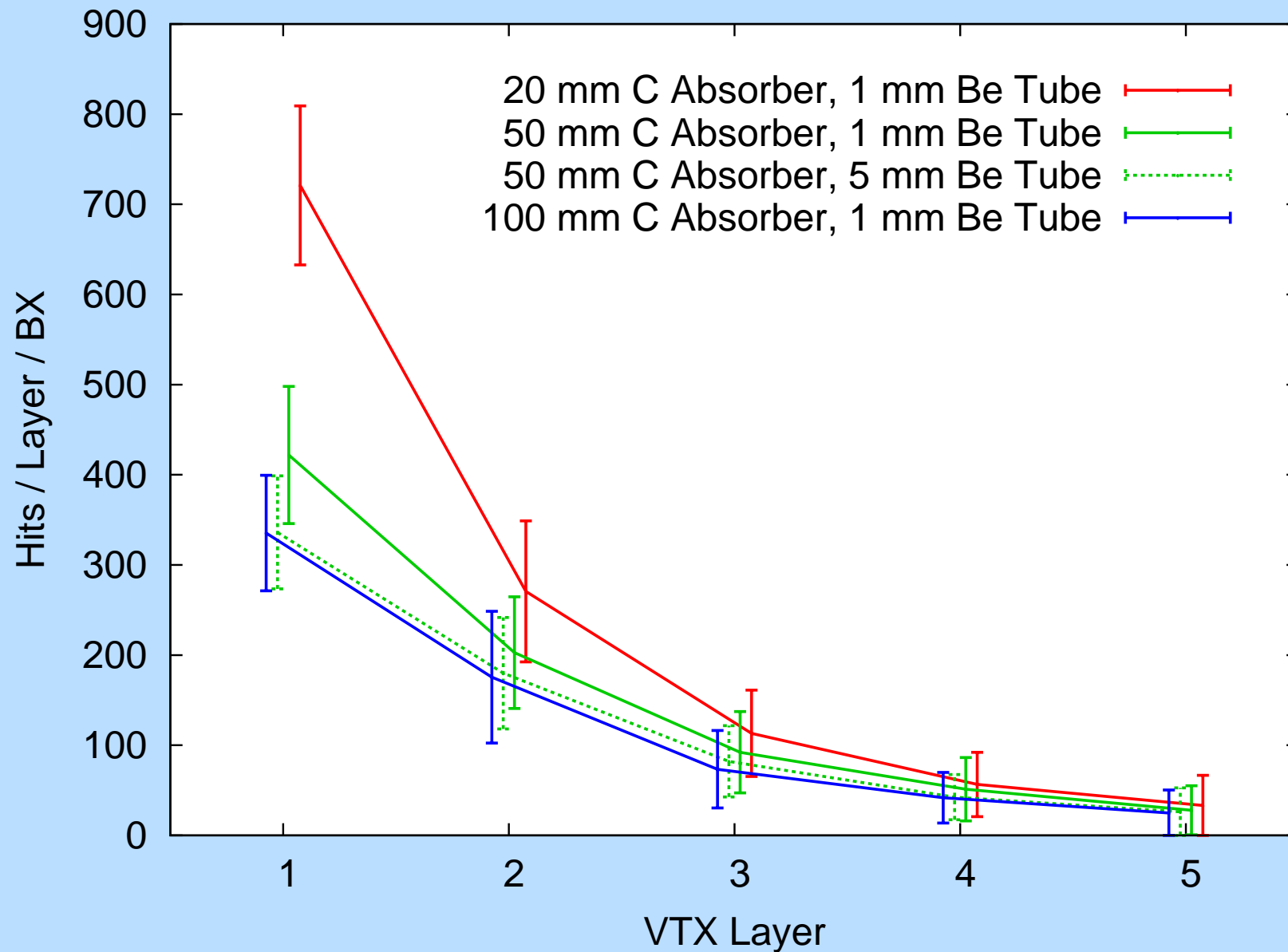

Hadronic Physics Lists

Processes can be implemented by different models

- electromagnetic physics are well-understood
- hadronic physics have a significant uncertainty
- neutron transport is the most difficult issue

Try out different hadronic physics lists provided by Geant4

- QGSP_BERT_HP – Bertini nuclear cascade
- LHEP_BIC_HP – binary nuclear cascade
- “HP” physics use a large cross-section database
- these are recommended for low-energy neutrons

Does the choice actually matter for our purposes?

VTX Hits – Geant4 Physics Lists

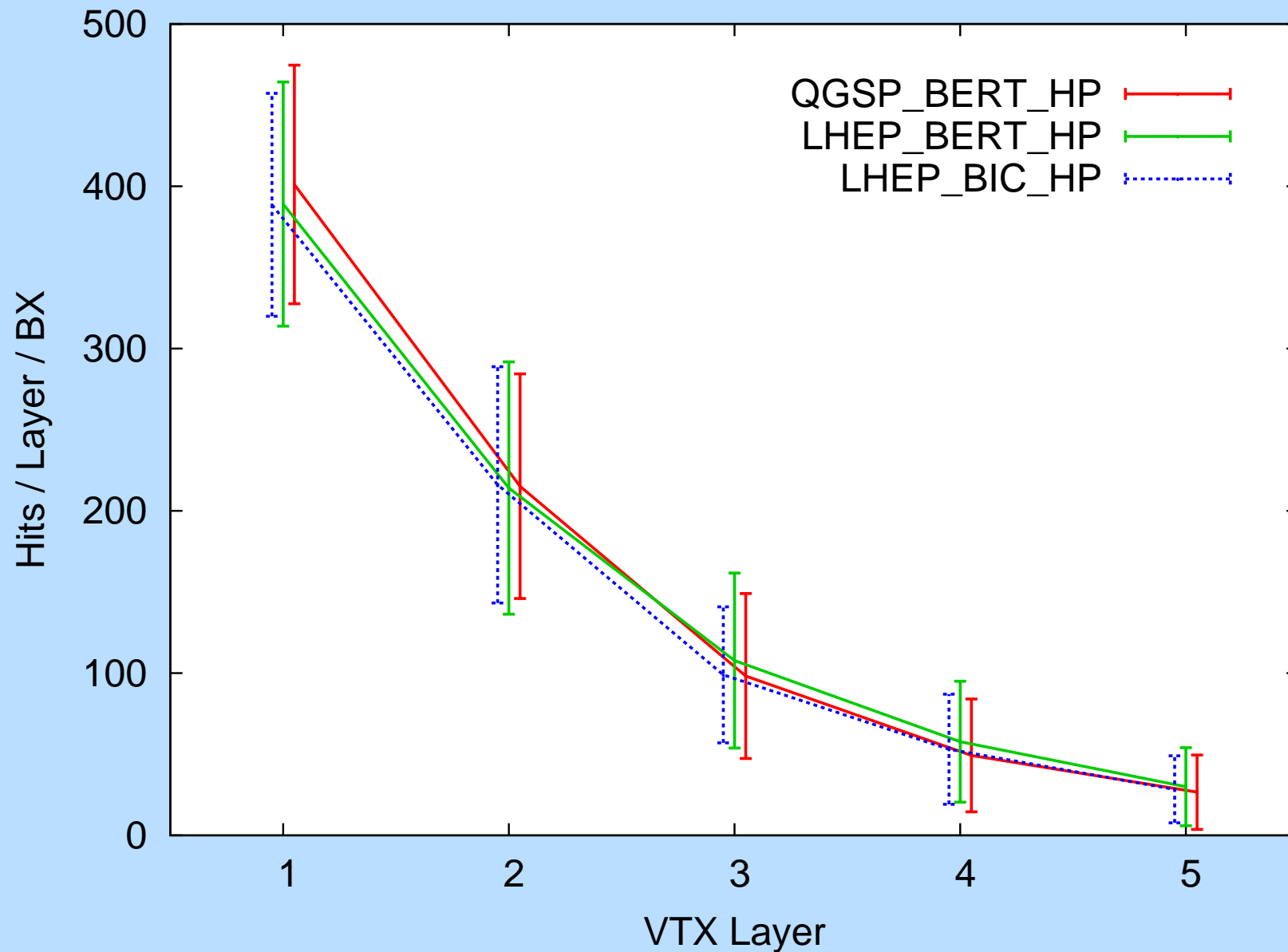

VTX – Neutron Energies

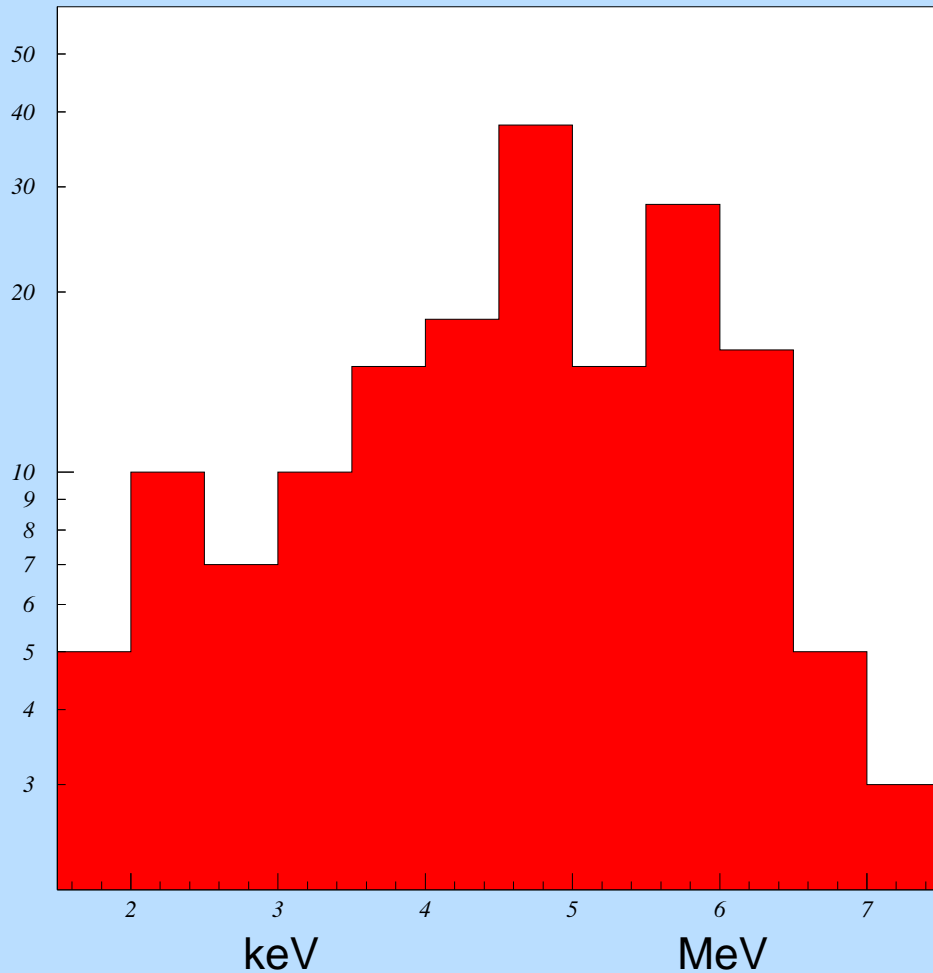

QGSP_BERT_HP

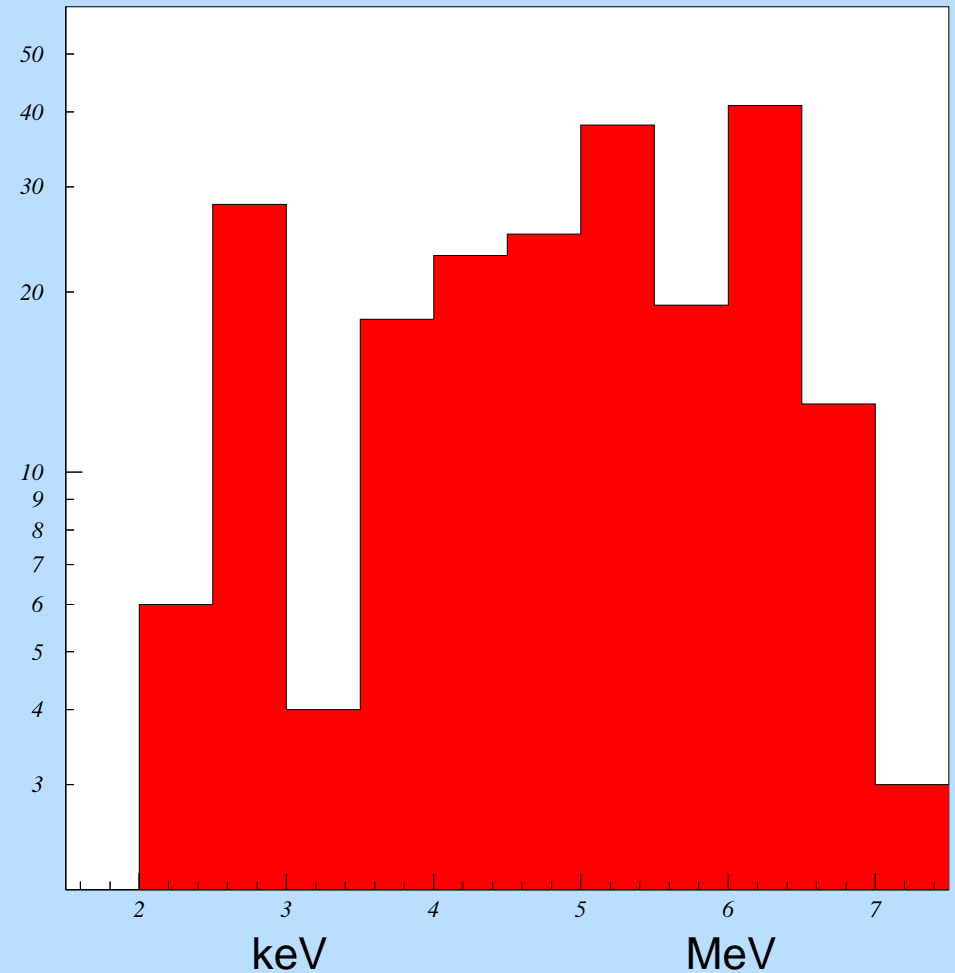

LHEP_BIC_HP

Energies of neutrons crossing the VTX (sum of 100 BX)

TPC Hits – “Salt and Pepper”

Mokka hits in the TPC (overlay of 100 BX)

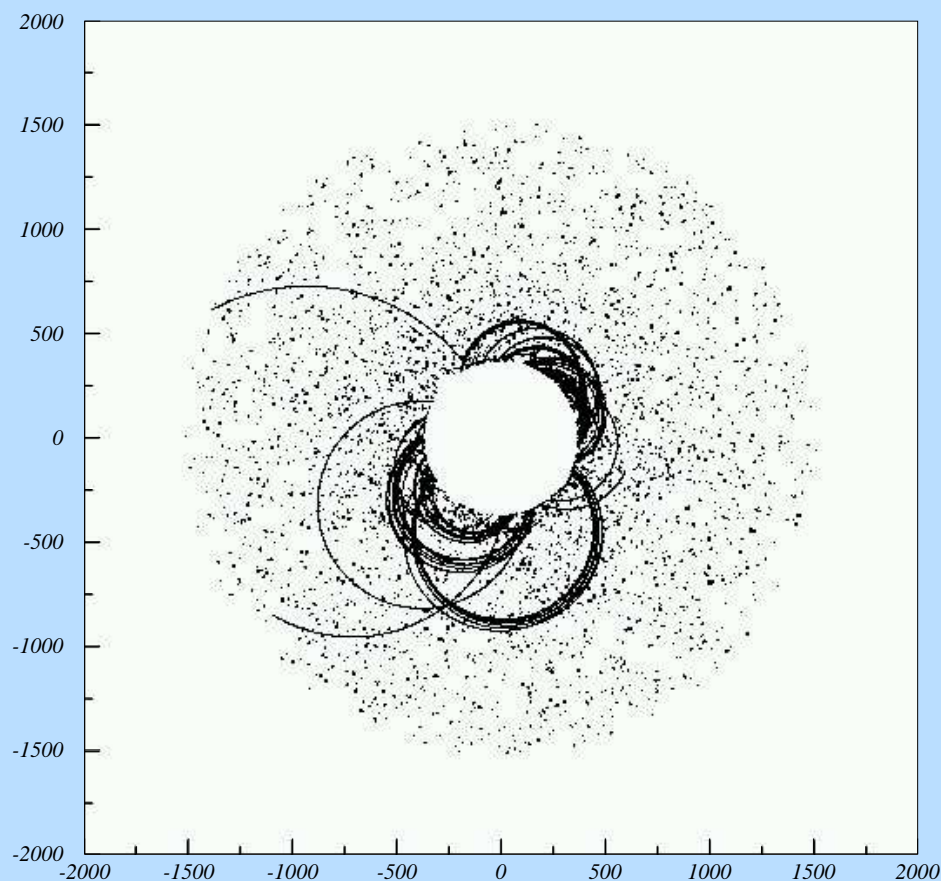

Front view

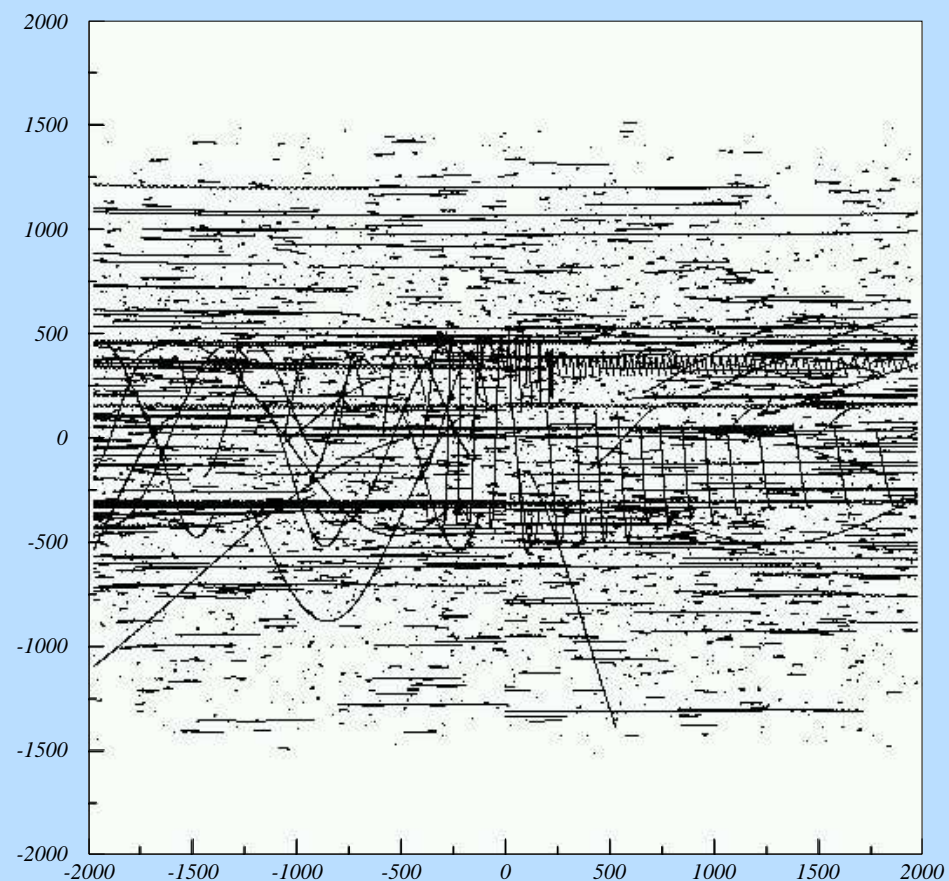

Side view

Summary and Outlook

Backscattering is important, but can be suppressed

- optimisation of the forward geometry
- small modifications (e. g. radii) can have large effects
- anti-DID field prevents particles from hitting the VTX
- 50 mm low- Z absorber seems reasonable

Further plans: focus more on the TPC

- simulation of a whole bunch train
- make a “background library” to superimpose on events
- include background in the full reconstruction chain

No major surprises! The whole picture is settling down . . .